

TABLE OF CONTENTS

GENERAL, SPECIAL TOOLS AND SERVICE MATERIALS	1
TROUBLE SHOOTING	2
ENGINE	3
CARBURETOR	4
AIR CLEANER, FUEL PUMP AND FILTER	5
ENGINE COOLING SYSTEM	6
CAR HEATER	7
IGNITION SYSTEM	8
STARTER MOTOR	9
CHARGING SYSTEM	10
CLUTCH	11
GEAR SHIFTING CONTROL	12
TRANSMISSION	13
TRANSFER GEAR BOX	14
PROPELLER SHAFTS	15
DIFFERENTIAL	16
SUSPENSION	17
STEERING SYSTEM	18
BRAKES	19
DOOR AND TARP TOP	20
BODY ELECTRICAL EQUIPMENT	21
SERVICE DATA & MAINTENANCE SCHEDULES	22
OTHERS	23

1. GENERAL

1-1. Body and Chassis of SUZUKI LJ80 and LJ80V.....	6
1-2. Outline Dimensions.....	9
1-3. Specifications.....	11
1-4. Locations of Body Number and Engine Number.....	14
1-5. Standard Shop Practices.....	15
1-6. Special Tools.....	17
1-7. Required Materials.....	21

1-1. Body and Chassis of SUZUKI LJ80 and LJ80V

LJ80

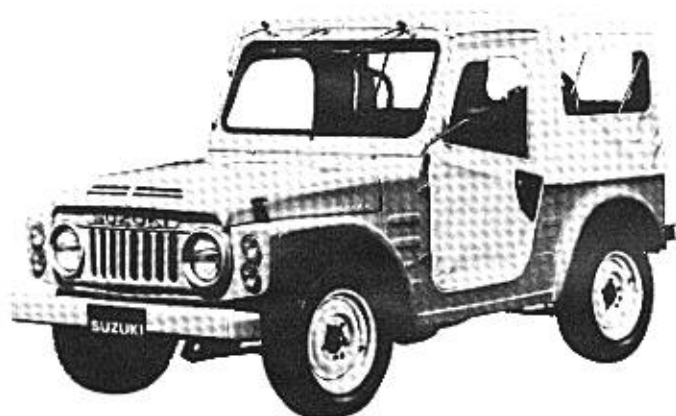

Fig. 1-1

LJ80V



Fig. 1-2

3) LJB0 & LJB0V chassis with engine

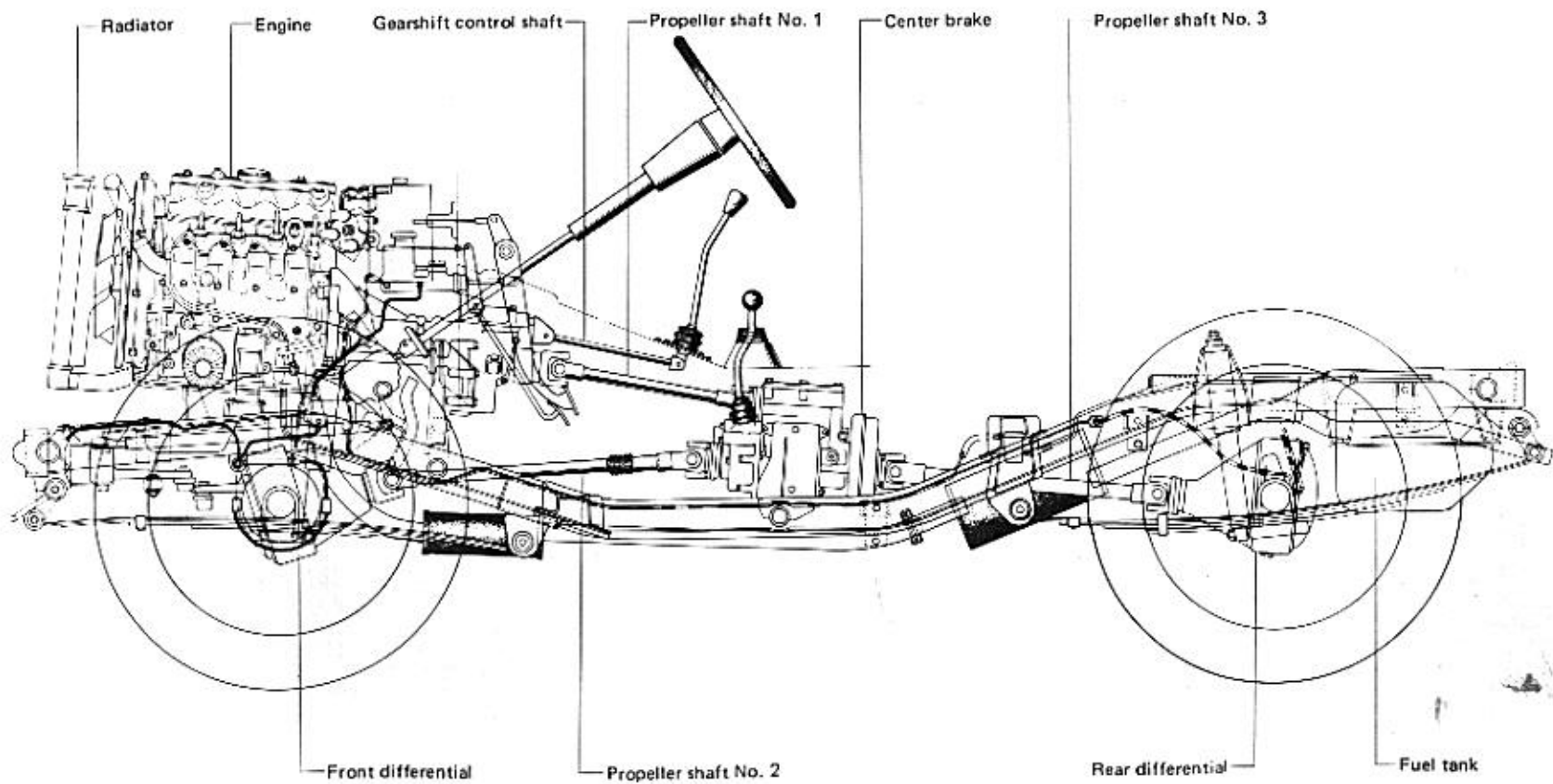
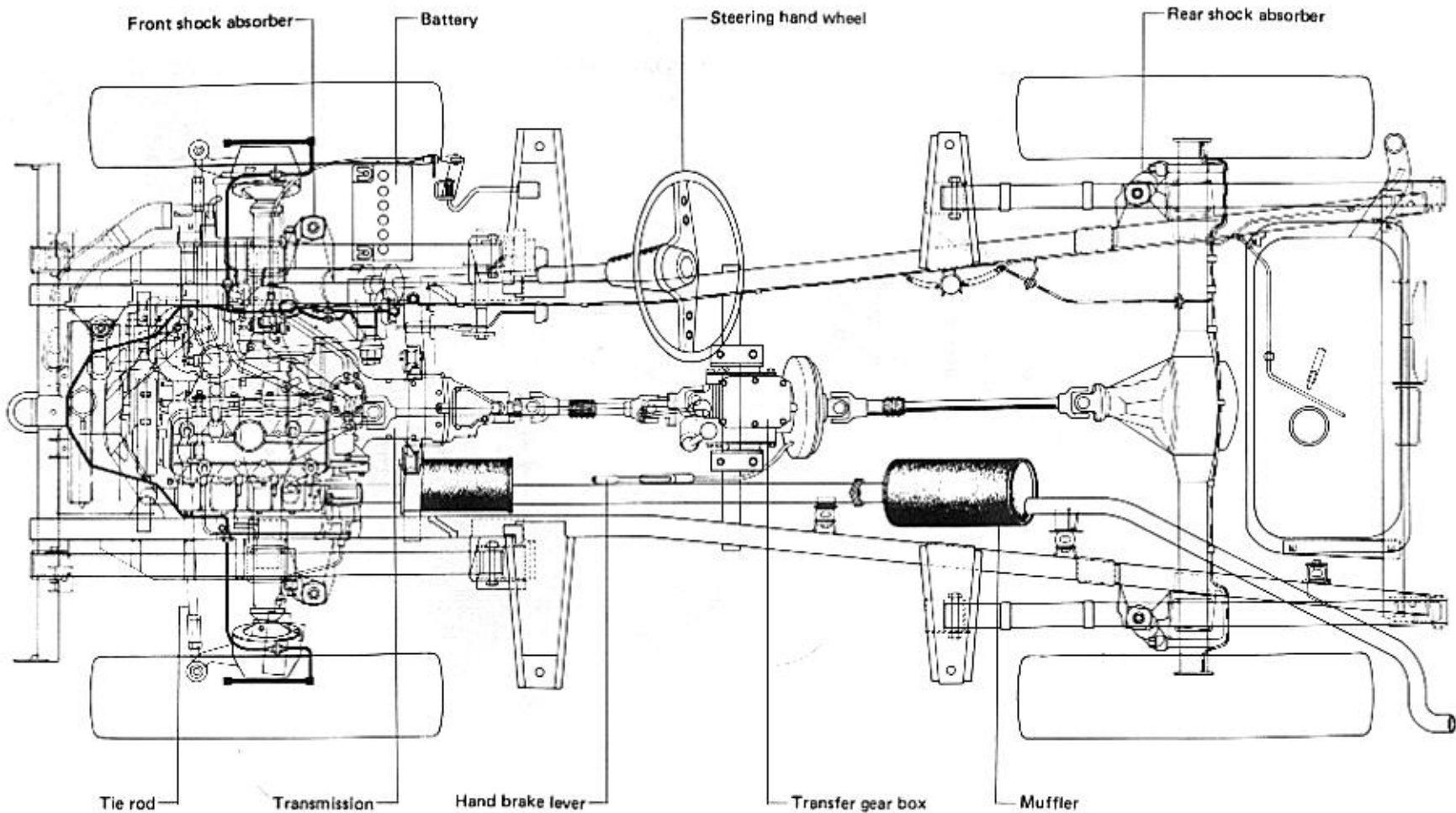
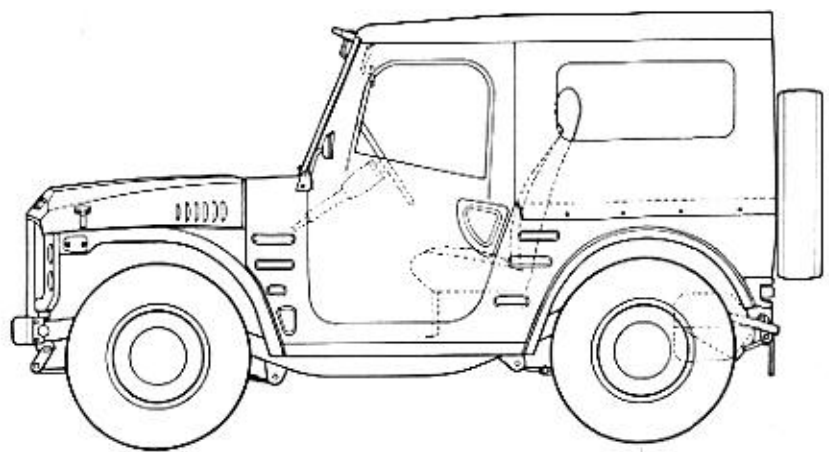
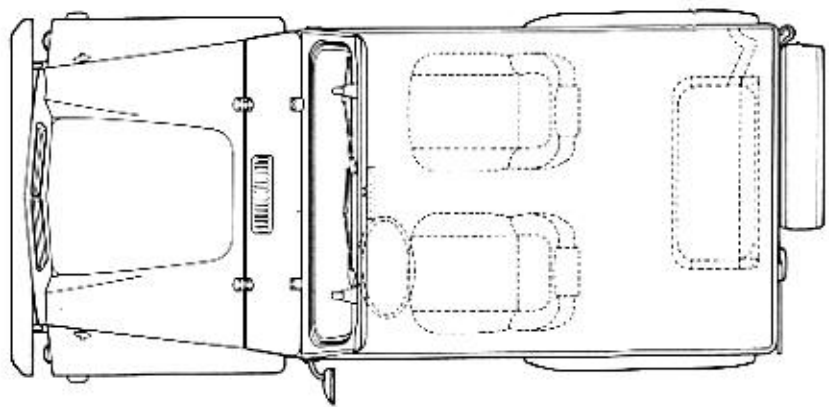

Fig. 1-3

Fig. 1-4



1-2. Outline Dimensions
1) L380



1,930 mm (76.0 in.)

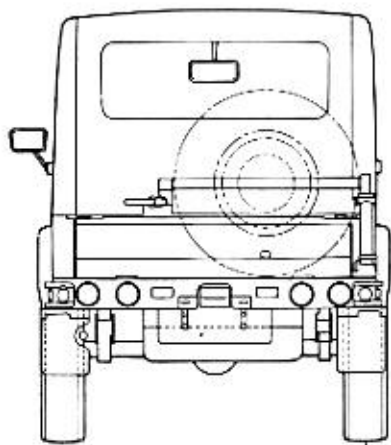

1,200 mm (47.2 in.)

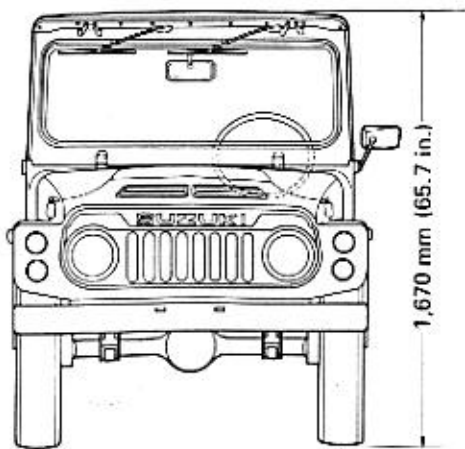

1,190 mm (46.9 in.)

1,670 mm (65.7 in.)

Fig. 1-5

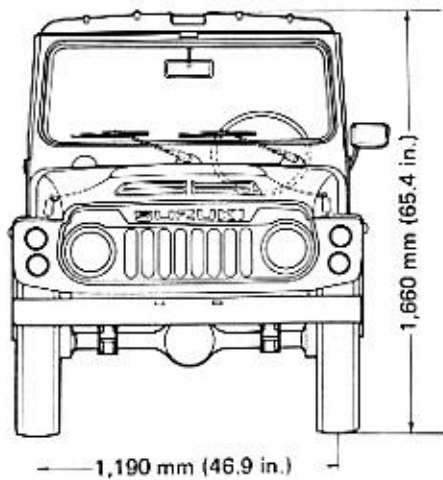
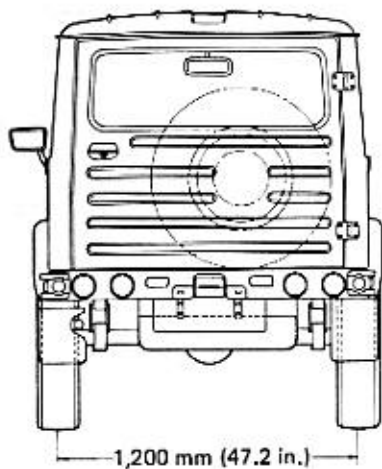
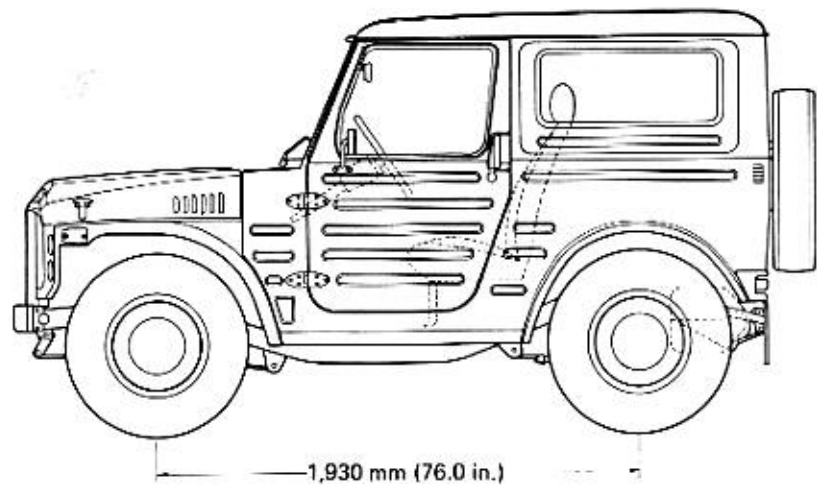
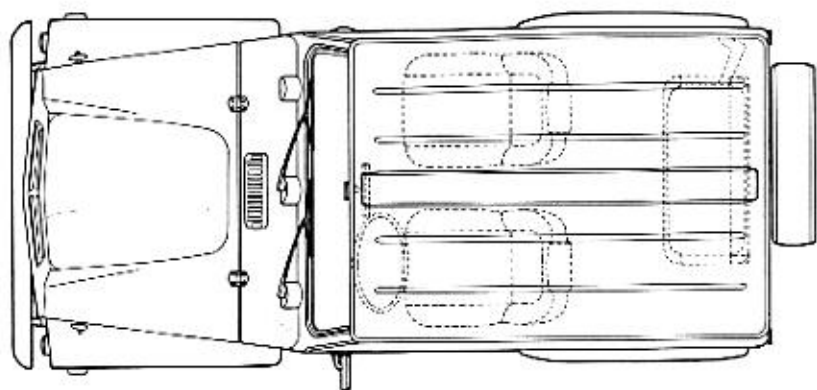

Fig. 1-6

1-3. Specifications

Models		LJ80	LJ80V
Item			
DIMENSIONS			
Overall length		3,195 mm (125.8 in)	←—————
Overall width		1,415 mm (55.7 in)	←—————
Overall height		1,670 mm (65.7 in)	1,660 mm (65.4 in)
Wheelbase		1,930 mm (76.0 in)	←—————
Tread: Front		1,190 mm (46.9 in)	←—————
Rear		1,200 mm (47.2 in)	←—————
Load deck size: Length		825 mm (32.5 in)	785 mm (30.9 in)
Width		1,205 mm (47.4 in)	1,190 mm (46.9 in)
Height		1,030 mm (40.6 in)	1,045 mm (41.1 in)
Ground clearance		195 mm (7.7 in)	←—————
WEIGHT			
Curb weight	Canvas door type	770 kg (1,698 lbs)	820 kg (1,808 lbs)
	Panel door type	790 kg (1,742 lbs)	
Weight distribution:			
Front	Canvas door type	420 kg (926 lbs)	435 kg (959 lbs)
	Panel door type	435 kg (959 lbs)	
Rear	Canvas door type	350 kg (772 lbs)	385 kg (849 lbs)
	Panel door type	355 kg (783 lbs)	
Gross vehicle weight		1,165 kg (2,570 lbs)	1,165 kg (2,570 lbs)
Seating capacity		2 person	←—————
Maximum loading capacity		250 kg (551 lbs)	200 kg (441 lbs)
ENGINE			
Type		Four-stroke cycle, water-cooled, SOHC	←—————
Number of cylinders		4	←—————
Lubrication system		Wet sump	←—————
Bore		62.0 mm (2.441 in)	←—————
Stroke		66.0 mm (2.598 in)	←—————
Piston displacement		797 cc (cm ³) (48.6 cu-in)	←—————
Compression ratio		8.7 : 1	←—————
Carburetor		MIKUNI 32PHD, single	←—————
Air cleaner		Polyurethane foam element	←—————

Item \ Models	LJ80	LJ80V
ELECTRICAL		
Ignition timing	10° B.T.D.C. below 850 rpm	—————
Standard spark plug	NGK BPR-5ES or NIPPON DENSO W16EXR-U	—————
Starter	Magnetic shift type	—————
Generator	Alternator	—————
Battery	12V, 45AH/20 hours	—————
Headlight	12V, 50/40 W	—————
Turn signal light	12V, 23W (32 cp)	—————
Combination light	12V, 8W (3 cp)	—————
Seat belt indicator light	12V, 3.4W	—————
Tail/Brake light	12V, 8/23W (3/32 cp)	—————
Side turn signal light	12V, 8W	—————
Licence plate light	12V, 10W (4 cp)	—————
Back up light	12V, 27W	—————
Room light	12V, 5W	—————
Meter pilot lights	12V, 3.4W	—————
Main fuse	30A	—————
Fuse box	10A, 15A, 20A	—————
Brake system warning light	12V, 3.4W	—————
POWER TRANSMISSION		
Clutch type	Dry, single disc	—————
Transmission type	4-forward all synchromesh, 1 reverse	—————
Transfer gear box type	2-speed constantmesh	—————
Final reduction ratio	4.556	—————
Gear ratios: Low	3.835	—————
2nd	2.359	—————
3rd	1.543	—————
Top	1.000	—————
reverse	4.026	—————
Transfer gear ratios:		—————
Low range	2.571	—————
High range	1.563	—————
Overall reduction ratios		—————
Low range: Low	44.924	—————
2nd	27.635	—————
3rd	18.073	—————
Top	11.715	—————
Reverse	47.170	—————

Item	Models	LJ80	LJ80V
High range:	Low	27.297	←
	2nd	16.792	←
	3rd	10.982	←
	Top	7.119	←
	Reverse	28.662	←
WHEEL AND SUSPENSION			
Tire size:	Front and rear	165 SR 15	←
Tire pressure:	Front (Unladen)	1.20 kg/cm ² (17 psi) (120 kPa)	←
	Rear (Unladen)	1.60 kg/cm ² (23 psi) (160 kPa)	←
	Front (Laden)	1.40 kg/cm ² (20 psi) (140 kPa)	←
	Rear (Laden)	2.00 kg/cm ² (29 psi) (200 kPa)	←
Suspension type:			←
	Front	Leaf spring	←
	Rear	Leaf spring	←
STEERING			
Turning radius		4.9 m (16.1 ft)	←
Steering gear box		Ball nut	←
Toe-in		1 ~ 5 mm (0.040 ~ 0.196 in)	←
Camber angle		1°	←
Caster angle		2°	←
Trail		10 mm (0.40 in)	←
King pin angle		9°	←
BRAKE SYSTEM			
Type		4-wheel, hydraulic	←
Wheel brake,	Front	two-leading	←
	Rear	Leading and trailing	←
Parking brake		Internal expanding on propeller shaft	←
CAPACITIES			
Cooling solution		3.8 lit (8.0/6.7 US/Imp pt)	←
Fuel tank		40 lit (10.6/8.8 US/Imp gal)	←
Engine oil		3.0 lit (6.3/5.3 US/Imp pt)	←
Transmission oil		1.0 lit (2.1/1.8 US/Imp pt)	←
Differential gear box oil		1.3 lit (2.7/2.3 US/Imp pt)	←
Transfer-gear box oil		0.9 lit (1.9/1.6 US/Imp pt)	←

1-4. Locations of Body Number and Engine Number

Body No. is punched on the front side of the upper face of the left frame under the water reservoir tank.

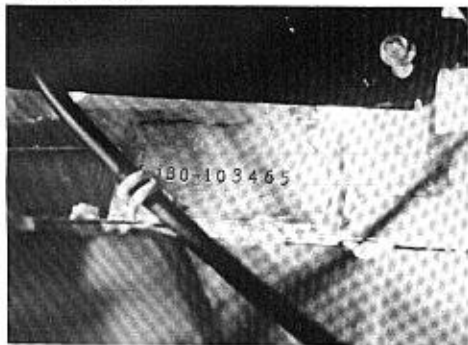

Fig. 1-7. Location of Body No.

The engine number is punched on the rear portion of the right-hand skirt part of cylinder block.

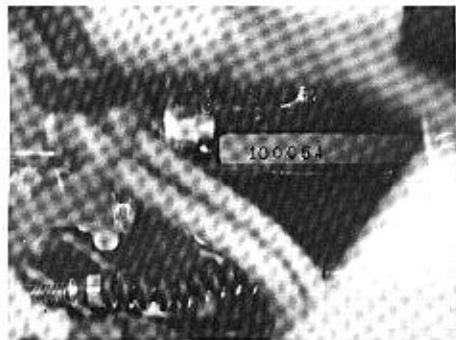

Fig. 1-8. Location of Engine No.

1-5. Standard Shop Practices

1. Protect the painted surfaces of the body, and avoid staining or tearing the seats. When working on the fenders and seats, be sure to cover them up with sheets.
2. Disconnect the negative terminal connection of the battery when working on any electrical part or component. This is necessary for avoiding electrical shocks and short-circuiting, and is very simple to accomplish: merely loosen the wing nut on the negative terminal and separate the cable from the terminal post.
3. In raising the front or rear end off the floor by jacking, be sure to put the jack up against the center portion of the axle housing.

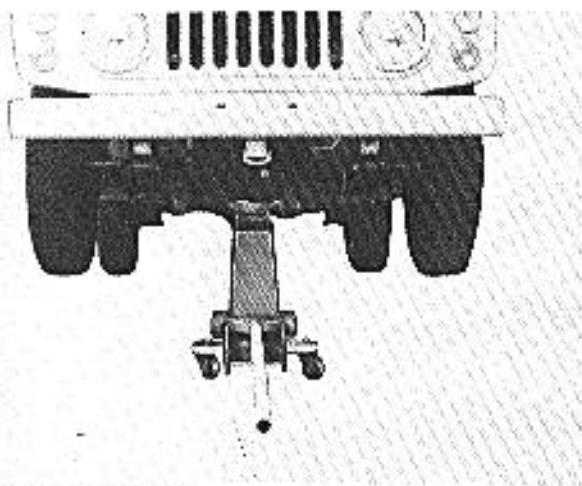

Fig. 1-9. Front side

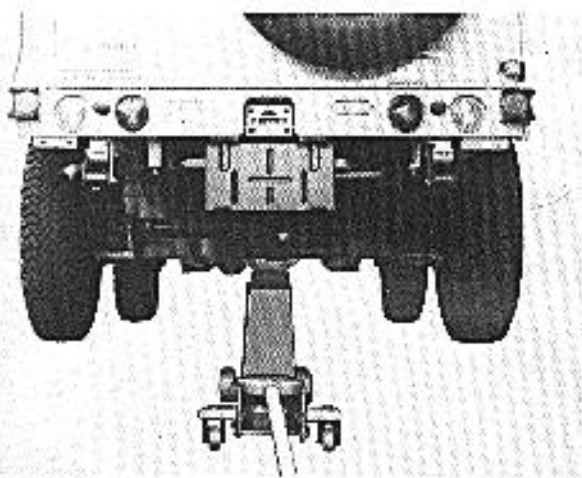

Fig. 1-10. Rear side

4. To work on the front or rear end raised by jacking, be sure to place the safety stand under the axle to support it in stable condition.

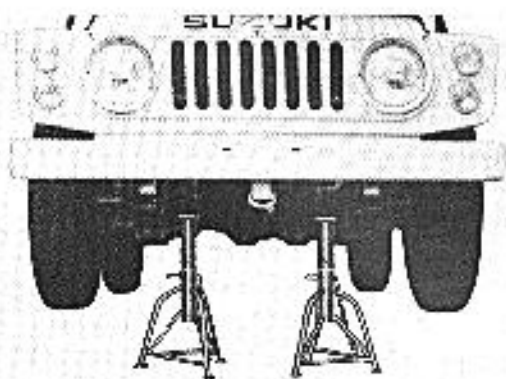

Fig. 1-11. Front side

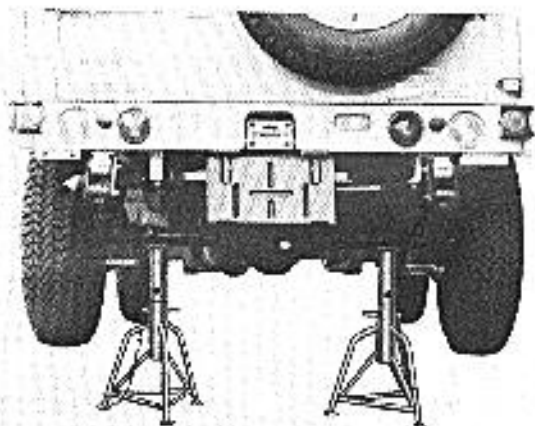

Fig. 1-12. Rear side

5. Have wheel chocks for ready use in the shop. Chock the wheels securely when raising one end of the machine.

6. Orderliness is a key to successful overhauling. Trays, pans and shelves are needed to set aside the disassembled parts in groups or sets in order to avoid confusion and misplacement. This is particularly important for engine overhauling.
7. Have on hand the liquid packing—SUZUKI BOND No. 4 (99000-31030) — for ready use. This packing dope is an essential item assures leak-free (water and oil) workmanship.
8. Each bolt must be put back to where it was taken from or for which it is intended. Do not depend on your hunch in tightening the bolts for which tightening torque values are specified: be sure to use torque wrenches on those bolts.
9. It is advisable to discard and scrap gaskets and "O" rings removed in disassembly. Use new ones in reassembly, and try not to economize gaskets and "O" rings.
10. Use of Genuine SUZUKI parts is imperative. Use of imitation parts is a big gamble on safety and performance. Use Genuine SUZUKI parts and live up to the trust your customer places on you.
11. Special tools save time and ensure good workmanship: They are available from SUZUKI. Use them where their use is specified. Moreover, your own safety is assured by the use of special tools in many of the disassembly and reassembly steps.
12. Refer to the contents of this MANUAL as often as practical, and do each job right as prescribed.

NOTE: The engine cylinders are identified by numbers. See Fig. 1-13. Counting from the front end, the cylinders are referred to as No. 1, No. 2, No. 3 and No. 4 cylinders.

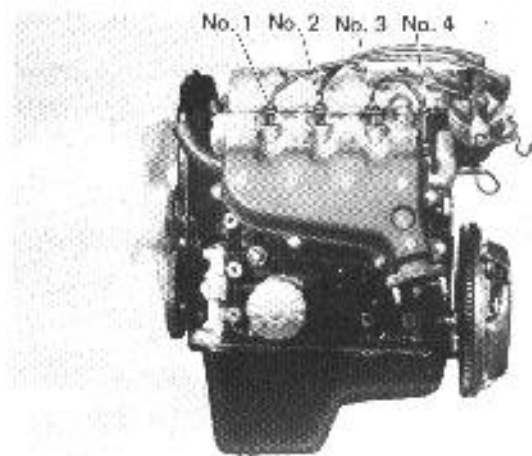

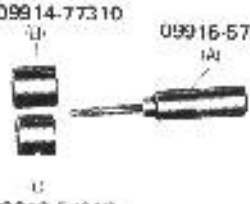











Fig. 1-13. Engine cylinder numbers

1-6. Special Tools

Special tools assure three things: 1) improved workmanship; 2) speedy execution of jobs for which they are meant; and 3) protection of parts and components against damage. Here are the special tools prescribed for the Model LJ80 and LJ80V:

<p>1.</p>  <p>09916-14510 Valve lifter</p>	<p>2.</p>  <p>09914-77310 09916-57320 09916-57310</p> <p>(A) Valve guide & valve stem seal handle (B) Valve stem seal installer attachment (C) Valve guide installer attachment</p>	<p>3.</p>  <p>09916-44510 Valve guide remover</p>
<p>4.</p>  <p>09916-34520 09916-34540 09916-37310</p> <p>Valve guide reamer (A) 7 mm dia. (B) 12.0 mm dia. (C) Handle</p>	<p>5.</p>  <p>09916-84510 Forceps</p>	<p>6.</p>  <p>09916-97310 Flywheel stopper</p>
<p>7.</p>  <p>09915-47310 Oil filter wrench</p>	<p>8.</p>  <p>09916-77310 Piston ring compressor</p>	<p>9.</p>  <p>09915-77310 Oil pressure gauge</p>
<p>10.</p>  <p>09915-64510 Compression gauge</p>	<p>11.</p>  <p>09915-67310 Vacuum gauge</p>	<p>12.</p>  <p>09930-40113 Camshaft lock holder</p>

13.

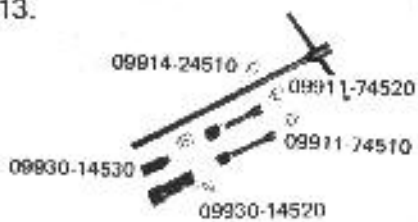

09930-14511 Cylinder head bolt &
Spark plug wrench set

(A) Plug wrench (B) Universal joint
(C) "T" handle
(D) 14 mm socket wrench
(E) 12 mm socket wrench

14.



09910-34510
Piston pin puller

15.



09900-09002
Shock driver set

16.



09900-25002
Pocket tester

17.



09900-27003
Ignition timing tester

18.



09900-28106
Electro tester

19.



09911-70120
Hexagon wrench 6 mm

20.



09913-60910
Bearing puller

21.



09913-75510
Differential rear outer
race installer

22.



09913-75520
Differential front outer
race installer

23.



09913-80111
Bearing installer

24.



09913-85210
Bearing installer

25.



09913-85230
Differential side bearing
remover jig

26.



09900-06107
Snap ring pliers (opening type)

27.



09900-06108
Snap ring pliers (closing type)

28.



09922-55131
Bearing installer

29.



09924-46310
Front axle installer

30.



09922-65122
Transfer input shaft puller

31.



09922-66010
Rear axle shaft remover

32.

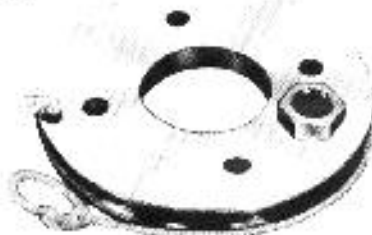

09922-75220
Differential pre-road
checking tool

33.



09922-85811
Spring pin remover

34.



09923-36310
Clutch center guide

35.



09923-57910
Differential side bearing
adjuster turner

36.



09940-53111
Differential side bearing
installer

37.



09924-36320
Bevel pinion mounting
dummy

38.



09942-15510
Sliding hammer

39.



09943-35511
Front drum remover

40.



09922-95210
Universal joint disassembling
tool set

41.



09941-03610
8 x 10 mm Hexagon
combination wrench

42.



09922-45810
Clutch release shaft
bush remover

43.



09900-27301
Timing-light (D.C. 12V)

44.



09900-27311
Timing light (Dry cell type)





45.



09900-20803
Thickness gauge

1-7. Required Materials

The materials listed below are needed for maintenance work on the LJ80 and LJ80V, and should be kept on hand for ready use. In addition, such standard materials as cleaning fluids, lubricants, etc., should also be available. Methods and time of use are discussed in the text of this manual on later pages.

Ref. No.	Material	Use
1.	<p>GOLDEN CRUISER 1200 "Anti-freeze and Summer Coolant" (99000-24120)</p> 	<p>Additive to engine cooling for improving cooling efficiency and for protection of wet walls against rusting.</p>
2.	<p>SUZUKI SUPER GREASE A (99000-25010)</p> 	<ul style="list-style-type: none"> • For locations indicated in the section dealing with the starter motor. • Clutch release bearing retainer. • Clutch release shaft bushing. • Transmission oil seal. • Differential oil seal. • Steering column. • Gear shifting control lever bushing & seat. • Door window regulator. • Steering tie rod lever bush.
3.	<p>SUZUKI GREASE SUPER H (99000-25120)</p> 	<p>Special grease intended for use on constant velocity joint.</p>
4.	<p>SUZUKI BOND (No. 4) (99000-31030)</p> 	<ul style="list-style-type: none"> • For top and bottom mating faces of transmission case. • For other locations specifically indicated in the text of this manual.

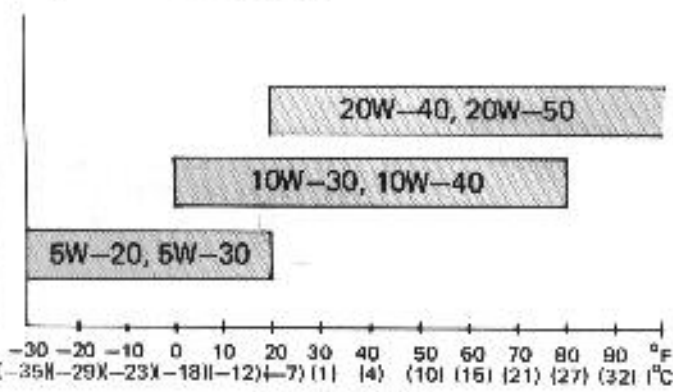
Ref. No.	Material	Use
5.	CHASSIS GREASE	<ul style="list-style-type: none"> • For grease nipples on propeller shafts. • For propeller shaft splines.
6.	THREAD LOCK CEMENT (99000-32040)	<ul style="list-style-type: none"> • Timing belt inside cover bolt • Drive bevel gear bolt
7.	GEAR OIL	<ul style="list-style-type: none"> • Transmission case 1.0 ltr. (2.12/1.76 US/Imp. pt.) • Transmission gear and bearing
	SAE # 90	<ul style="list-style-type: none"> • Transfer case 0.9 ltr. (1.90/1.60 US/Imp. pt.) • Steering gear box • Differential gear box (Hypoid gear oil) 1.3 ltr. (2.75/2.31 US/Imp. pt.)
8.	SUZUKI LOCK SUPER "103K" (99000-32030)	<ul style="list-style-type: none"> • Reduction driven gear (on the transmission) • Third drive gear (counter shaft)
9.	WHEEL BEARING GREASE	<ul style="list-style-type: none"> • Front wheel bearing • Rear wheel bearing
10.	SUZUKI SUPER GREASE C (99000-25030)	<ul style="list-style-type: none"> • Propeller shaft universal joint spider bearing
11.	<p>4-STROKE ENGINE OIL</p> <p>Proper oil viscosity chart</p>  <p>Temperature</p>	<ul style="list-style-type: none"> • For engine oil pan: 3.0 litres (6.34/5.28 US/Imp. pt.) for periodical oil change but 3.5 litres (7.39/6.16 US/Imp. pt.) for refilling at the time of engine overhauling. • Crank journal bearings and thrust plate. • Connecting-rod big-end and small-end bearings. • Camshaft journals and thrust plate. • Rocker shafts. • Oil pump gears. • Pistons and piston rings. • Engine oil seals. • Valve stems. • Accelerator, choke and clutch cables. • Parking brake cable. • Accelerator, brake and clutch pedals. • Door locks and hinges • Distributor gear.

2. TROUBLE SHOOTING

2-1. Engine.....	24
2-2. Carburetor.....	30
2-3. Exhaust and Muffler.....	30
2-4. Clutch.....	30
2-5. Transmission.....	31
2-6. Differentials.....	32
2-7. Propeller Shafts.....	33
2-8. Brakes.....	33
2-9. Front Suspension and Steering System.....	34
2-10. Starting Motor.....	35
2-11. Alternator.....	36
2-12. Wiper Motor.....	37
2-13. Fuel Meter.....	38
2-14. Turn Signal Lights.....	38
2-15. Speedometer.....	39
2-16. Water Temperature Meter.....	39
2-17. Oil Pressure Warning Light.....	39
2-18. Charge Warning Light.....	40
2-19. Horn.....	40

2-1. Engine

Complaint	Possible causes	Remedy	Page
Poor starting	Starter will not run		
	1. Main fuse is blown off.	Replace.	
	2. Contact is not closing in main switch, or this switch is open-circuited.	Repair or replace.	
	3. Run-down battery.	Recharge.	150
	4. Defective starting relay.	Repair or replace.	
	5. Loose terminal connection on the battery.	Clean and retighten.	152
	6. Defective brushes in starter.	Replace.	137
	7. Loose battery cord connection.	Retighten.	
	8. Open in field or armature circuit of starter.	Repair or replace.	136
	No sparking		
	1. Defective spark plug.	Adjust the gap, or replace.	124/ 125
	2. Short-circuit (grounded) fault in high-tension cords.	Repair or replace defective cords.	
	3. Cracked rotor or cap in distributor.	Replace.	125
	4. Burnt breaker contact points.	Replace.	125/ 128
	5. Breaker contact gap out of adjustment.	Adjust as prescribed.	128
	6. Defective condenser.	Replace.	126
	7. Contact is not closing positively in main switch, or this switch is open-circuited.	Replace.	
	8. Loose or blown fuse.	Set right, or replace.	
	9. Ignition timing out of adjustment.	Adjust as prescribed.	128
	10. Defective ignition coil.	Replace.	128
	Faulty intake and exhaust systems		
	1. Carburetor needs readjustment.	Adjust as prescribed.	97
	2. Fuel pump is not discharging adequately.	Replace.	
	3. Clogged air cleaner.	Clean, or replace.	102
	4. Defective choke mechanism.	Repair or replace.	97
	5. Loose intake manifold.	Retighten.	
	6. Carburetor is dirty and clogged.	Disassemble and clean.	97
	7. Float level out of adjustment.	Adjust as prescribed.	88
8. Clogged fuel hose.	Clean or replace.		
9. Not enough fuel in the tank.	Refill.		
10. Clogged exhaust ports.	Clean.		
Abnormal internal condition in engine			
1. Ruptured cylinder head gasket.	Replace.		
2. Valve clearance out of adjustment.	Adjust as prescribed.	84	
3. Weakened or broken valve spring.	Replace.	61	
4. Loose manifold, permitting air to be drawn in.	Retighten and, as necessary, replace the gasket.		
5. Worn pistons, rings or cylinders.	Replace worn rings and pistons and, as necessary, rebore.	63	

Complaint	Possible causes	Remedy	Page
	6. Broken valve timing belt. 7. Poor valve seating. 8. Wrong kind of engine oil. 9. Burnt valves.	Replace. Repair or replace. Replace. Replace.	70/80 59 92
Not enough power	<p>Inadequate compression</p> 1. Valve clearance out of adjustment. 2. Valves not seating tight. 3. Valve stems tending to seize. 4. Broken or weakened valve spring. 5. Piston rings seized in grooves, or broken. 6. Worn pistons, rings or cylinders. 7. Leaky cylinder head gasket.	Adjust as prescribed. Repair; Replace. Replace. Replace. Replace worn parts and, as necessary, rebore. Replace.	84 59 61 64
	<p>Improperly timed ignition</p> 1. Ignition timing out of adjustment. 2. Defective spark plug. 3. Breaker point gap out of adjustment. 4. Leaky high-tension cords for some cylinders. 5. Distributor governor is not working correctly.	Adjust as prescribed. Adjust the gap, or replace. Adjust or replace. Replace. Repair.	128 124/ 125 128
	<p>Fuel system out of order</p> 1. Clogged carburetor. 2. Defective fuel pump. 3. Clogged fuel filter. 4. Choke wire working erratically. 5. Float level out of adjustment. 6. Clogged fuel pipe. 7. Clogged fuel tank outlet. 8. Loose joint in fuel system.	Disassemble and clean. Repair or replace. Replace. Adjust. Adjust. Clean or replace. Clean. Retighten.	97 104 97 98
	<p>Abnormal condition in air intake system</p> 1. Air cleaner dirty and clogged. 2. Poor returning motion of choke valve.	Clean or replace. Repair, adjust or replace.	102 97
	<p>Clogged exhaust system</p> 1. Muffler is clogged with carbon.	Clean.	
	<p>Overheating tendency of engine</p> 1. (Refer to the section entitled "overheating.")		
	<p>Others</p> 1. Dragging brakes. 2. Slipping clutch.	Adjust as prescribed. Adjust or replace.	232 157

Complaint	Possible causes	Remedy	Page
Sudden drop of speed in high-speed cruise	Abnormal condition in electrical systems	Adjust as prescribed.	128
	1. Breaker contact point gap too large.	Adjust as prescribed.	125
	2. Spark plug gap too large.	Replace.	
	3. Cracked rotor or cap in distributor, resulting in leakage.	Replace.	126
	4. Defective condenser.	Replace.	126
	5. Deteriorated ignition coil, or crack resulting in leakage.	Replace.	126
	6. Leaky high-tension cords.	Replace.	
	7. Ignition timing out of adjustment.	Adjust as prescribed.	128
	Abnormal condition in fuel system	Adjust as prescribed.	98
	1. Float level set too low.	Clean.	97
2. Clogged condition of main jet circuit in carburetor.	Replace.		
3. Inadequately discharging fuel pump.	Replace.		
Abnormal condition in engine	Replace.		
1. Loss of compression pressure due to leaky cylinder head gasket.	Replace and, as necessary, rebore.	25	
2. Compression pressure too low because of worn pistons, rings, cylinders or burnt valves.			
Engine not responding quickly to pedal control in picking up speed	Abnormal condition in electrical system	Adjust as prescribed.	128
	1. Ignition timing out of adjustment.	Replace, or adjust as prescribed.	124/ 125
	2. Defective spark plug, or plug gap out of adjustment.	Replace.	
	3. Leaky high-tension cords for some cylinders.	Adjust or replace.	125/ 128
	4. Breaker contact points out of adjustment or defective.	Replace.	126
	5. Defective condenser.		
	Abnormal condition in fuel system	Adjust as prescribed.	98
	1. Float level too low or too high.	Clean.	97
	2. Clogged jets in carburetor.	Clean or replace.	102
	3. Air cleaner is dirty and clogged.		
	Abnormal condition in engine	Clean.	
	1. Exhaust ports dirty with carbon.	Clean.	
	2. Muffler clogged with carbon.	Replace worn running parts, or rebore.	25
	3. Compression pressure too low.	Repair.	59
	4. Poorly seating valves.	Adjust as prescribed.	84
5. Valve clearance out of adjustment.	Replace and, as necessary, rebore.	63	
6. Pistons tending to seize.	Replace.		
7. Bearings tending to seize.			

Complaint	Possible causes	Remedy	Page
Erratic idling	Abnormal condition in ignition system <ol style="list-style-type: none"> 1. Ignition timing out of adjustment. 2. Defective spark plug, or plug gap too large. 3. Cracked cap in distributor, there being leakage inside. 4. Leaky high-tension cords. 5. Cracked rotor in distributor, there being leakage inside. 	Adjust as prescribed. Replace, or adjust. Replace. Replace. Replace.	128 124/ 125 125
	Abnormal condition in fuel system <ol style="list-style-type: none"> 1. Carburetor idling adjustment is disturbed. 2. Clogged pilot jet in carburetor. 3. Float level out of adjustment. 4. Air cleaner is dirty and clogged. 5. Air is being sucked in due to loose joints or broken parts. 6. Broken carburetor packing. 	Adjust as prescribed. Clean. Adjust as prescribed. Clean or replace. Retighten, or replace. Replace.	99 97 98 102
	Abnormal condition in engine. <ol style="list-style-type: none"> 1. Exhaust ports clogged with carbon. 2. Valve clearance out of adjustment. 3. Poorly seating valves. 4. Blown cylinder head gasket. 	Clean. Adjust as prescribed. Repair. Replace.	84 50
Abnormal detonation	Abnormal condition in ignition system <ol style="list-style-type: none"> 1. Spark plugs are tending to overheat. 2. Ignition timing out of adjustment. 3. Defective breaker contact points. 4. Loose connection in high-tension or low-tension circuit. 	Change plug heat value. Adjust as prescribed. Replace. Retighten.	124 128 125/ 128 122
	Abnormal condition in fuel system <ol style="list-style-type: none"> 1. Air-fuel mixture too lean. 2. Carburetor is dirty inside. 3. Float level out of adjustment. 4. Water inside carburetor. 5. Air is leaking in through inlet manifold joint. 	Clean and adjust. Clean. Adjust as prescribed. Clean. Retighten.	97 98
	Abnormal condition in engine <ol style="list-style-type: none"> 1. Excessive carbon deposit on piston crowns or cylinder head. 2. Blown cylinder head gasket, resulting in low compression pressure. 3. Valve clearance out of adjustment. 4. Valves tending to seize. 5. Weakened valve springs. 	Clean. Replace. Adjust as prescribed. Replace. Replace.	55 84 61

Complaint	Possible causes	Remedy	Page
Overheating	Abnormal condition in ignition system 1. Ignition timing out of adjustment. 2. Wrong heat value of spark plugs. 3. Breaker point gap out of adjustment in distributor.	Adjust as prescribed. Change heat value. Adjust as prescribed.	128 124/ 125 128
	Abnormal condition in fuel and exhaust systems 1. Float level set too low. 2. Clogged jets in carburetor. 3. Loose inlet manifold. 4. Clogged exhaust ports.	Adjust as prescribed. Clean. Retighten. Clean.	98 97
	Abnormal condition in cooling system 1. Not enough coolant. 2. Loose or broken fan belt. 3. Erratically working thermostat. 4. Poor water pump performance. 5. Leaky radiator cores.	Refill. Adjust or replace. Replace. Replace. Repair or replace.	115 114 114
	Abnormal condition in lubrication system 1. Clogged oil filter. 2. Clogged oil strainer. 3. Deteriorated oil pump performance. 4. Oil leakage from oil pan or pump. 5. Wrong kind of lubrication oil. 6. Not enough oil in oil pan.	Replace. Clean. Replace. Repair. Change. Replenish.	91 89 92 92
	Others 1. Dragging brakes. 2. Slipping clutch. 3. Blown cylinder head gasket.	Adjust. Adjust or replace. Replace.	232 157
	Abnormal engine noise	Crankshaft noise 1. Worn-down bearings, resulting in excessively large running clearances. 2. Worn connecting-rod bearings. 3. Distorted connecting rods. 4. Worn crankshaft journals. 5. Worn crankpins.	Replace. Replace. Repair or replace. Repair by grinding, or replace crankshaft. Repair by grinding, or replace crankshaft.
Noise due to pistons, rings, pins or cylinders 1. Abnormally worn bores of cylinders. 2. worn pistons, rings or pins. 3. Pistons tending to seize. 4. Broken piston rings.		Rebore to next oversize or replace. Replace and, as necessary, rebore to next oversize. Replace. Replace.	63 64

Complaint	Possible causes	Remedy	Page
	Others 1. Excessively large camshaft thrust play. 2. Excessively large crankshaft thrust clearance. 3. Valve clearance too large. 4. Not enough engine oil.	Replace. Adjust as prescribed. Adjust as prescribed. Replenish.	62 68 84 92
High fuel consumption	Abnormal condition in ignition system 1. Ignition timing out of adjustment. 2. Leaky high-tension cords. 3. Breaker point gap maladjusted. 4. Wrong heat value of spark plugs. 5. Cracked distributor cap or rotor. Abnormal condition in fuel system 1. Float level set too high. 2. Fuel leakage from tank, pipe or carburetor. 3. Erratic returning action of choke valve. 4. Pilot screw set incorrectly. 5. Clogged breather in carburetor. 6. Air cleaner is dirty and clogged. Abnormal condition in engine 1. Leakage of combustion gases from cylinder head. 2. Valve seating poorly. 3. Valve clearance out of adjustment. Others 1. Dragging brakes. 2. Slipping clutch.	Adjust as prescribed. Replace. Adjust or replace. Change heat value. Replace. Adjust as prescribed. Repair or replace. Repair and adjust. Adjust as prescribed. Clean. Clean or replace. Retighten, or replace head gasket. Repair. Adjust as prescribed. Adjust as prescribed. Adjust or replace.	128 128 124/ 125 125 98 97 99 102 59 84 232 157
Excessive engine oil consumption	Oil leakage 1. Oil drain plugs loose. 2. Loose oil pan securing bolts. 3. Broken oil pan gasket. 4. Leaky oil seals. 5. Blown cylinder head gasket. 6. Oil filter malpositioned or loose. "Oil pumping" (Oil finding its way into combustion chambers.) 1. Oil rings are worn or broken. 2. Piston ring end gaps are not staggered as prescribed. 3. Badly worn ring grooves. 4. Worn pistons or cylinders.	Retighten. Retighten. Replace. Replace. Replace. Set the pump right, or retighten mounting bolts. Replace. Reposition rings. Replace pistons. Replace pistons and, as necessary, rebore.	 65 73 85 64

Complaint	Possible causes	Remedy	Page
	Oil leakage along valve stems 1. Defective valve stem oil seals. 2. Badly worn valves or valve guide bushes.	Replace. Replace.	57

2-2. Carburetor

Complaint	Possible causes	Remedy	Page
Fuel overflow from carburetor	1. Float valve is worn or dirty with foreign matter.	Clean or replace.	97
	2. Float level is set too high. 3. Float is ruptured and contains some fuel. 4. Broken or otherwise defective gasket. 5. Loose float chamber securing screws. 6. Fuel pump discharge pressure too high.	Adjust as prescribed. Replace. Replace. Retighten. Adjust.	98

2-3. Exhaust and Muffler

Complaint	Possible causes	Remedy	Page
Poor muffling performance	1. Loose exhaust pipe connection. 2. Broken muffler gasket. 3. Broken manifold, pipe or muffler. 4. Exhaust manifold loose in place. 5. Interference between body and muffler.	Retighten. Replace. Repair or replace. Retighten. Repair, eliminating any contact.	

2-4. Clutch

Complaint	Possible causes	Remedy	Page
Slipping clutch	1. Loss of clearance at the tip of release fork.	Adjust as prescribed.	157
	2. Clutch facings dirty with oil.	Replace.	
	3. Clutch facings excessively worn.	Replace.	155
	4. Weakened diaphragm spring.	Replace.	
	5. Distorted pressure plate or flywheel surface.	Replace.	70
	6. Not enough play of clutch pedal.	Adjust and, as necessary, replace clutch facings.	157/ 155

Complaint	Possible causes	Remedy	Page
Dragging clutch	1. Excessive clutch pedal play.	Adjust as prescribed.	157
	2. Weakened diaphragm spring, or worn spring tip.	Replace.	
	3. Damaged or worn splines of transmission input shaft.	Replace.	156
	4. Front input shaft bearing worn or broken.	Replace.	156
	5. Excessively wobbly clutch disc.	Replace.	
	6. Clutch facings broken or dirty with oil.	Replace.	
Clutch vibration	1. Glazed (glass-like) clutch facings.	Repair or replace.	
	2. Clutch facings dirty with oil.	Replace.	
	3. Wobbly clutch disc, or poor facing contact.	Replace.	
	4. Weakened torsion springs (in clutch disc).	Replace.	
	5. Clutch disc rivets loose.	Replace the disc.	
	6. Distorted pressure plate or flywheel surface.	Replace.	70
	7. Weakened engine mounts (cushion pads).	Retighten or replace.	
Noisy clutch	1. Worn or broken release (throw-out) bearing.	Replace.	156
	2. Front input shaft bearing worn down.	Replace.	156
	3. Excessive rattle of clutch disc hub.	Replace the disc.	156
	4. Cracked clutch disc.	Replace.	
	5. Pressure plate and diaphragm spring are rattling.	Replace.	
Grabbing clutch	1. Clutch facings are soaked with oil.	Replace.	
	2. Clutch facings are excessively worn.	Replace.	155
	3. Rivet heads are showing out of the facing.	Replace.	155
	4. Torsion springs are weakened.	Replace.	

2-5. Transmission

Complaint	Possible causes	Remedy	Page
Gears slipping out of mesh	1. Distorted shift rod.	Repair or replace.	
	2. Worn shift fork shaft.	Replace.	
	3. Worn locating steel balls.	Replace.	
	4. Weakened springs for locating steel balls.	Replace.	172
	5. Worn shift fork.	Replace.	
	6. Excessive rattle in thrust direction of gears.	Replace.	
	7. Worn ring or hub in synchronizers.	Replace.	171
	8. Worn bearings of input shaft, main shaft or countershaft.	Replace.	170
Gears refusing to disengage	1. Weakened or broken synchronizer springs.	Replace.	
	2. Worn inner groove of synchronizer ring.	Replace.	171
	3. Synchronizer ring is seized on the cone.	Replace the ring.	
	4. Distorted shift fork shaft or shift fork.	Replace.	
	5. Worn shift fork.	Replace.	

Complaint	Possible causes	Remedy	Page	
Excessive gear noise	1. Not enough oil in transmission.	Replenish.	176	
	2. Defective synchronizer.	Replace.	170	
Hard shifting	3. Gears rattling in thrust direction.	Replace.		157
	4. Broken or worn bearings.	Replace.		
	1. Clutch pedal play too large, resulting in a "dragging clutch."	Adjust as prescribed.	155	
	2. Clutch disc facings are worn.	Replace.		
	3. Clutch disc facings are dirty with oil.	Replace.	171	
	4. Distorted or unevenly worn shift fork shaft.	Replace.		
	5. Broken locating balls.	Replace.		
6. Worn synchronizer sleeve.	Replace.			
7. Worn synchronizer hub.	Replace.			

2-6. Differentials

Complaint	Possible causes	Remedy	Page
Breakage (case, gears, bearings, etc.)	1. Insufficient or wrong kind of gear oil.	Replenish or change.	205
	2. Improperly shimmed side bearings or pinion bearings.	Adjust as prescribed.	199
	3. Improper mesh of drive pinion with ring gear.	Adjust or replace.	202
	4. Excessive backlash due to worn side gear thrust washer and pinion thrust washer.	Adjust or replace.	198
	5. Distorted rear axle housing.	Replace.	201
	6. Loose bolts securing ring gear.	Replace.	
Gear noise	1. Maladjusted backlash between drive pinion and ring gear.	Adjust as prescribed.	201
	2. Damaged gear teeth or improper mesh of drive pinion and ring gear.	Replace or adjust.	199
	3. Improper tooth contact in the mesh between drive pinion and ring gear.	Adjust as prescribed.	202
	4. Insufficient or wrong kind of gear oil.	Replenish or replace.	205
	5. Ring gear wobbles when turning, or ring gear securing bolts are loose.	Replace, or retighten.	
	6. Broken or otherwise damaged teeth of side gears or differential pinion gears.	Replace.	205
1. (Constant noise) Insufficient or wrong kind of gear oil.	Replenish or change.		
2. (Constant noise) Damaged or worn bearings or borne parts.	Replace.		
3. (Noise during coasting) Damaged bearings of rear drive pinion.	Replace.		
Bearing noise	4. (Noise during turning) Broken bearings on axle shafts.	Replace.	205

2-7. Propeller Shafts

Complaint	Possible causes	Remedy	Page
Vibration and noise	<ol style="list-style-type: none"> 1. Broken or worn bearings of universal joint spider. 2. Distorted propeller shaft. 3. Unbalanced propeller shaft. 4. Loose propeller shaft. 	Replace. Replace. Replace. Retighten.	191
Noise occurring at standing start or during coasting	<ol style="list-style-type: none"> 1. Worn or damaged universal joint. 2. Worn propeller shaft splines, due to lack of lubrication. 3. Loose propeller shaft. 4. Loose flanged yoke of universal joint. 	Replace. Replace. Retighten. Retighten.	191 191

2-8. Brakes

Complaint	Possible causes	Remedy	Page
Not enough braking force	1. Brake oil leakage from brake lines.	Locate the leaking point and repair.	232
	2. Drum-to-shoe clearance out of adjustment.	Adjust as prescribed.	
	3. Overheated brakes.	Determine the cause or overheating, and repair.	231
	4. Poor contact of shoes on brake drum.	Adjust for proper contact.	
	5. Brake shoes stained with oil or wet with water.	Replace.	
	6. Badly worn brake shoe linings.	Replace.	231
Uneven braking (Brakes not working in unison.)	1. Shoe linings are wet with water or stained with oil in some brakes.	Clean or replace.	231
	2. Drum-to shoe clearance out of adjustment in some brakes.	Adjust as prescribed.	232
	3. Drum is out of round in some brakes.	Replace.	230
	4. Wheel tires are inflated unequally.	Inflate equally.	222
	5. Defective wheel cylinders	Repair or replace.	224
	6. Disturbed front wheel alignment	Adjust as prescribed.	
Pedal stroke too large	1. Drum-to-shoe clearance out of adjustment.	Adjust as prescribed.	232
	2. Air trapped in the brake oil circuit.	Bleed air out as prescribed.	231
	3. Brake pedal improperly adjusted.	Adjust as prescribed.	232
	4. Brake oil leakage.	Locate the leaking point and repair.	232
	5. Not enough oil in the brake fluid reservoir.	Replenish.	
	6. Excessively worn brake drums.	Replace.	230
	7. Distorted or poorly contacting brake shoes.	Repair or replace.	231
	8. Defective cup in master cylinder.	Replace.	
	9. Worn brake shoes.	Replace.	

Complaint	Possible causes	Remedy	Page
Dragging brake	<ol style="list-style-type: none"> 1. Clogged return port in master cylinder. 2. Brake shoes improperly mounted on backing plate. 3. Weakened or broken return springs in the brake. 4. Defective wheel cylinders. 5. Sluggish parking-brake cables or linkage. 6. Brake shoes improperly adjusted. 	<p>Clean. Repair.</p> <p>Replace.</p> <p>Repair or replace. Repair or replaces. Adjust as prescribed.</p>	232
Pedal pulsation (Pedal pulsates when depressed for braking.)	<ol style="list-style-type: none"> 1. Damaged or out-of-round brake drums. 2. Damaged wheel bearings. 3. Distorted steering knuckle or rear axle shafts. 	<p>Replace.</p> <p>Replace.</p> <p>Replace.</p>	230
Braking noise	<ol style="list-style-type: none"> 1. Glazed shoe linings, or foreign matters stuck to linings. 2. Worn or loose shoe linings. 3. Broken front wheel bearings. 4. Distorted or loose backing plates. 	<p>Repair or replace.</p> <p>Replace.</p> <p>Replace.</p> <p>Replace, or retighten securing bolts.</p>	231 231

2-9. Front Suspension and Steering System

Complaint	Possible causes	Remedy	Page
Hard steering	<ol style="list-style-type: none"> 1. Wheel tires not adequately inflated. 2. Tie rod ends tending to seize. 3. Linkage connections tending to seize. 4. Steering gearbox out of adjustment. 5. Unevenly worn steering shaft bush. 6. Poorly lubricated or worn joints in linkage. 7. Disturbed front wheel alignment. 	<p>Adjust the pressure.</p> <p>Replace.</p> <p>Repair or replace.</p> <p>Adjust as prescribed.</p> <p>Replace.</p> <p>Lubricate or replace.</p> <p>Adjust as prescribed.</p>	223 221 224
Wobbly steering wheel	<ol style="list-style-type: none"> 1. Wheel tires inflated unequally. 2. Wobbly wheels. 3. Large difference in tire diameter between right and left wheels. 4. Loose hub nuts. 5. Damaged or worn wheel bearings. 6. Worn or loose tie rod ends. 7. Steering gearbox out of adjustment. 8. Steering gearbox mounted loose. 9. Worn steering center lever. 10. Worn steering knuckle oil seal. 	<p>Adjust the pressure.</p> <p>Repair or replace.</p> <p>Replace.</p> <p>Retighten.</p> <p>Replace.</p> <p>Replace or retighten.</p> <p>Adjust as prescribed.</p> <p>Retighten.</p> <p>Replace.</p> <p>Replace.</p>	222 221 212

Complaint	Possible causes	Remedy	Page
Steering wheel pulling to one side	<ol style="list-style-type: none"> 1. Unevenly worn wheel tires. 2. Brake dragging in one road wheel. 3. Wheel tires unequally inflated. 4. Worn or distorted link rods. 5. Disturbed front wheel alignment. 	Replace. Repair. Adjust the pressure. Replace. Adjust as prescribed.	 232 222 224
Shocks coming to steering wheel	<ol style="list-style-type: none"> 1. Tire inflating pressure too high. 2. Poor shock absorber performance. 3. Differences in tire diameter amount the four road wheels. 4. Worn steering linkage connections. 5. Worn or broken front wheel bearings. 6. Loose front wheel. 7. Steering wheel loose in place. 	Reduce to the specification. Replace. Adjust. Replace. Replace. Retighten. Retighten the nut.	222 222
Rapid wear or uneven wear of wheel tires	<ol style="list-style-type: none"> 1. Wheel tires improperly inflated. 2. Differences in diameter among the four tires. 3. Worn or loose road wheel bearings. 4. Wobbly wheel tires. 5. Wheel tires improperly "rotated" to result in unbalance. 6. Disturbed front wheel alignment. 	Adjust the pressure. Adjust or replace. Replace. Repair or replace. Adjust. Adjust as prescribed.	222 223 224
Steering noise	<ol style="list-style-type: none"> 1. Loose bolts and nuts. 2. Loose leaf spring seats. 3. Broken or otherwise damaged wheel bearings. 4. Worn or sticky tie rod ends. 5. Linkage joints needing grease. 	Retighten. Retighten. Replace. Replace. Lubricate or replace.	

2-10. Starting Motor

Complaint	Possible causes	Remedy	Page
Starter runs but pinion will not mesh into ring gear.	<ol style="list-style-type: none"> 1. Worn pinion of starter clutch. 2. Defective splines, resulting in sticky pinion plunging motion. 3. Worn bush. 4. Wrong pinion plunging position. 5. Worn teeth of ring gear. 	Replace. Repair or replace. Replace. Adjust. Replace.	

Complaint	Possible causes	Remedy	Page
Starter will not run at all, or runs but runs too slow to crank with full force.	Battery trouble	Repair or retighten.	152
	1. Poor contact in battery terminal connection.	Retighten.	152
	2. Loose grounding cable connection.	Recharge.	
	3. Battery run down.	Replace.	
4. Battery voltage too low due to battery deterioration.			
	Ignition switch trouble	Replace.	
	1. Poor contacting action.	Retighten.	
	2. Lead wire socket loose in place.	Repair.	
	3. Open-circuit between ignition switch and magnet switch.		
	Magnet switch trouble	Retighten.	
	1. Lead wire socket loose in place.	Replace, or repair.	
	2. Burnt contact plate, or poor contacting action.	Replace.	
	3. Open-circuit in pull-in coil.	Replace.	
4. Open-circuit in holding coil.			
	Starter proper trouble	Repair or replace.	137
	1. Brushes are seating poorly or worn down.	Repair or replace.	136
	2. Burnt commutator.	Replace.	136
	3. Open-circuit in armature winding.	Replace.	
4. Worn-down starter.			
Starter does not stop running.	1. Fused contact points of magnet-switch contact plate.	Repair or replace.	
	2. Short-circuit between turns of magnet-switch coil (layer short-circuit).	Replace.	
	3. Failure of returning action in ignition switch.	Replace.	

2-11. Alternator

Complaint	Possible causes	Remedy	Page
Battery quickly becomes over-discharged.	1. Loose or broken "V" belt.	Adjust or replace.	114
	2. Open-circuit in stator winding.	Repair or replace.	146
	3. Open-circuit in rotor winding.	Repair or replace.	145
	4. Excessively worn slip ring brushes.	Replace.	146
	5. Weakened brush springs.	Replace.	
	6. Regulator setting too low. (Regulated voltage too low.)	Adjust as prescribed.	147
	7. Poor contacting action of low-speed point in regulator.	Repair.	147
	8. Fused high-speed contact point in regulator.	Repair, or replace.	

Complaint	Possible causes	Remedy	Page
	9. Improper acid concentration in or low level of battery electrolyte.	Replace, or replenish.	150
	10. Defective battery cell plates.	Replace the battery.	152
	11. Insufficient contact in battery terminal connection.	Clean and retighten.	
	12. Open-circuit between two "F" terminals (one on regulator and the other on alternator), or high resistance.	Repair.	142
	13. Excessive electrical load.	Advise the user to economize.	
Battery tends to become overcharged.	1. Regulated voltage set too high.	Adjust as prescribed.	147
	2. Poorly grounded "E" terminal of regulator.	Repair.	142
	3. Open-circuit in voltage regulator pressure coil.	Replace.	
	4. Fused low-speed point of regulator.	Repair or replace.	142
	5. Poor contacting action of high-speed point of regulator.	Repair or replace.	
	6. Open-circuit or high resistance between two "N" terminals (one on alternator and the other on regulator).	Repair.	
Alternator noise	1. Worn, loose or otherwise defective bearings.	Replace.	

2-12. Wiper Motor

Complaint	Possible causes	Remedy	Page
Wiper will not run.	1. Fuse is set loose or blown off. 2. Incomplete metal-to-metal contact in connector. 3. Worn or floating brushes. 4. Dirty or burnt commutator. 5. Short-circuited or fused field coil. 6. Loose terminal connection on wiper switch.	Tighten or replaces. Repair. Replace or repair. Repair or replace. Replace. Repair.	
Wiper will not stop running.	1. Defective wiper switch.	Repair or replace.	
Wiper stops at wrong position.	1. Improper wiper arm setting. 2. Cover plate incorrectly positioned in place.	Repair. Repair.	
Poor wiping action.	1. Insufficient pressure of wiper arm. 2. Deteriorated or hardened blade. 3. Blade improperly set. 4. Windshield dirty with oil.	Replace. Replace. Repair or replace. Clean.	

2-13. Fuel Meter

Complaint	Possible causes	Remedy	Page
Faulty meter indication	<ol style="list-style-type: none"> 1. Incomplete metal-to-metal contact in terminal connections. 2. Defective receiver gauge due to burnt point or deformed bimetal element. 3. Erratic float movement. 4. Defective grounding (for float and gauge). 	<p>Retighten.</p> <p>Replace.</p> <p>Repair or replace.</p> <p>Repair.</p>	
No indication	<ol style="list-style-type: none"> 1. Open-circuit. 2. Open-circuited heat wire. 3. Burnt point. 4. Deformed bimetal element. 5. Open-circuited resistor. 	<p>Repair.</p> <p>Replace.</p> <p>Replace.</p> <p>Replace.</p> <p>Replace.</p>	250

2-14. Turn Signal Lights

Complaint	Possible causes	Remedy	Page
Flashing frequency is higher on one side, or flashing occurs only on one side, right or left.	<ol style="list-style-type: none"> 1. Lights are imperfectly grounded. 2. Lights of wrong watt ratings are used. 3. One of the light bulbs is blown on right or left side or on front or rear side. 4. Defective turn signal relay. 5. Open circuit or high resistance between switch and lights. 	<p>Repair.</p> <p>Replace.</p> <p>Replace.</p> <p>Replace.</p> <p>Repair.</p>	
No flashing on occurs on both sides, right and left.	<ol style="list-style-type: none"> 1. Blown fuse in turn signal circuit. 2. Open-circuit or high resistance between battery and switch. 3. Defective turn signal relay. 	<p>Replace.</p> <p>Repair.</p> <p>Replace.</p>	
Flashing frequency is too low, or no flashing occurs on both sides.	<ol style="list-style-type: none"> 1. Lights of a smaller watt rating than the specification rating are used. 2. One of the lights on right or left side or on front or rear side is poorly grounded. 3. Supply voltage is too low. 4. Fuse set loose in place, resulting in poor contact. 5. Incomplete metal to-metal contact in connector. 6. Defective turn signal relay. 	<p>Replace.</p> <p>Repair.</p> <p>Recharge the battery.</p> <p>Repair or replace.</p> <p>Repair.</p> <p>Replace.</p>	152
Flashing frequency is too high.	<ol style="list-style-type: none"> 1. Lights of a larger wattage than the specification are used. 2. Defective flasher. 	<p>Replace.</p> <p>Replace.</p>	

2-15. Speedometer

Complaint	Possible causes	Remedy	Page
Faulty indication	<ol style="list-style-type: none"> 1. Damaged speedometer drive or driven gear. 2. Defective drive cable. 3. Drive cable incompletely or improperly tied into the meter. 4. Defective speedometer. 	Replace. Replace. Set right. Replace.	
Speedometer noise	<ol style="list-style-type: none"> 1. Inadequately lubricated or defective cable. 2. Not enough oil in transfer. 	Lubricate or replace. Replenish.	188

2-16. Water Temperature Meter

Complaint	Possible causes	Remedy	Page
Faulty indication	<ol style="list-style-type: none"> 1. Incomplete metal to-metal contact in terminal connections. 2. Receiver gauge defective (due to burnt point or deformed bimetal element). 3. Defective temperature gauge. 	Repair and tighten. Replace. Replace.	
No indication	<ol style="list-style-type: none"> 1. Open-circuit. 2. Defective receiver gauge (open-circuited heat wire, deformed bimetal element or pointer). 3. Defective temperature gauge. 	Repair Replace. Replace.	113

2-17. Oil Pressure Warning Light

Complaint	Possible causes	Remedy	Page
Turning ignition switch on (for engine starting) does not light this light.	<ol style="list-style-type: none"> 1. Light bulb is blown. 2. Blown-off fuse. 3. Defective oil pressure switch. 4. Open-circuit between light and ignition switch. 5. Open-circuit between light and pressure switch. 	Replace. Replace. Replace. Repair. Repair.	
Light remains burning even after engine starts up.	<ol style="list-style-type: none"> 1. Not enough oil in engine oil pan. 2. Oil pressure too low. 3. Defective oil pressure switch. 	Replenish. Repair or replace the pump. Replace.	92 89

2-18. Charge Warning Light

Complaint	Possible causes	Remedy	Page
Turning ignition switch on (for engine starting) does not light this light.	<ol style="list-style-type: none">1. Light bulb is blown.2. Blown-off fuse.3. Open-circuit.4. High resistance in circuit wire due to loose connection.	Replace. Replace. Replace. Retighten.	
Light remains burning even after engine starts up.	<ol style="list-style-type: none">1. Alternator is not producing full output.2. Defective voltage regulator.3. Ground-circuit formed between light and the battery.	Repair. Repair or replace. Repair.	36 147

2-19. Horn

Complaint	Possible causes	Remedy	Page
Horn will not sound off.	<ol style="list-style-type: none">1. Blown-off fuse.2. Broken circuit wire.3. Defective horn.	Replace. Repair. Replace.	
Poor sound quality	<ol style="list-style-type: none">1. Incomplete contacting action inside horn switch.2. Improper point gap or burnt point inside the horn.3. Cracked diaphragm.	Repair. Repair or replace. Replace.	

3. ENGINE

3-1. Description	42
3-2. Engine Services Not Requiring Engine Removal	45
3-3. Dismounting the Engine	46
3-4. Engine Disassembly	47
3-5. Engine Maintenance Service	55
3-6. Engine Reassembly	71
3-7. Engine Inspection and Adjustments	84
3-8. Engine Lubrication	88

3-1. Description

- 1) The engine is a water-cooled, in-line 4 cylinders, 4-stroke cycle gasoline unit with its S.O.H.C. (single overhead camshaft) valve mechanism arranged for "V"-type valve configuration.

The single overhead camshaft (S.O.H.C.) is mounted over the cylinder head; it is driven from crankshaft through timing belt. Unlike conventional overhead valve (O.H.V.) engines, this engine has no pushrods. Thus, drive for valves is more direct and enables the valves to follow the crankshaft without any delay.

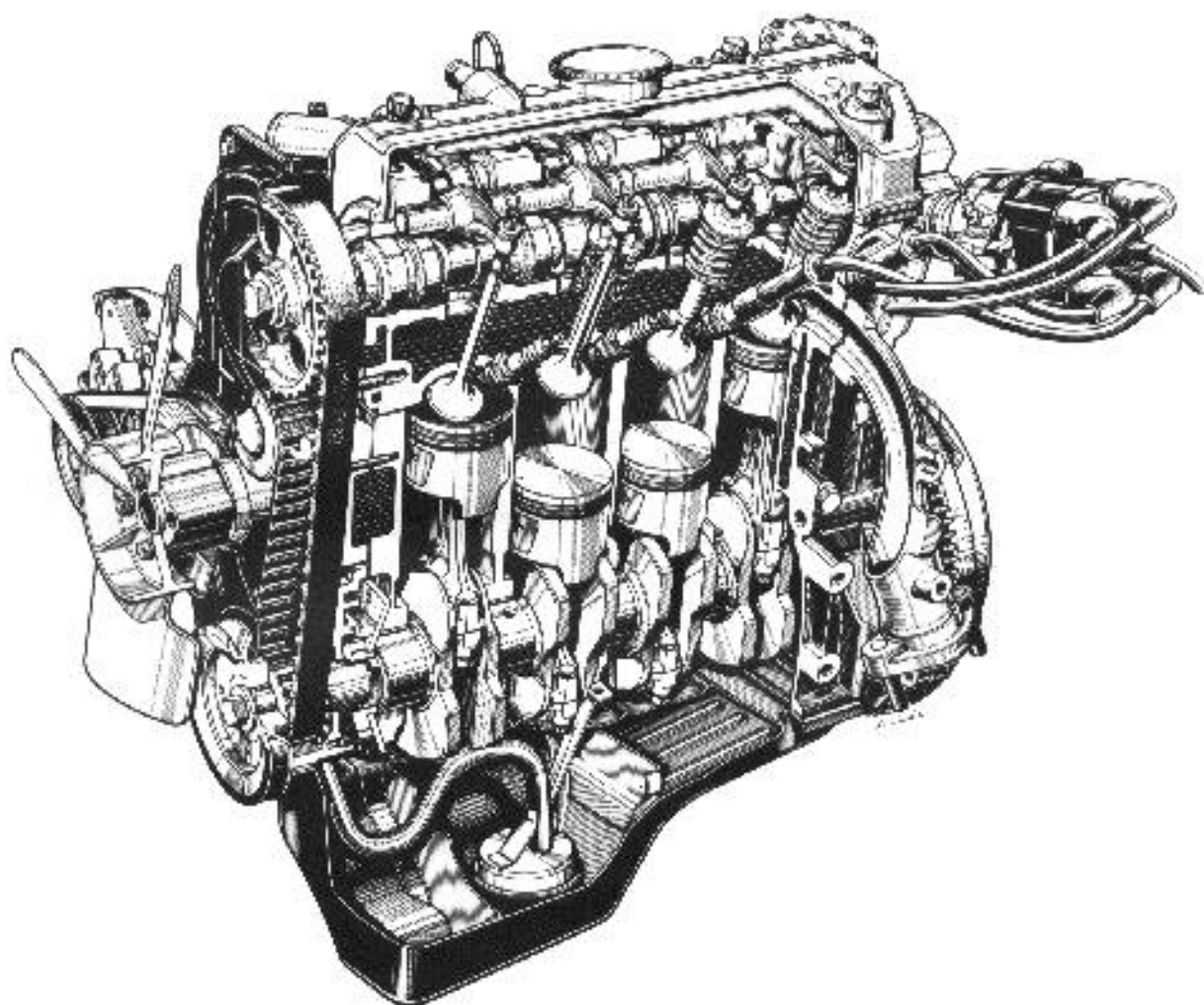

Fig. 3-1

2) The distinctive features of this engine may be summarized as follows:

1. Because of inlet and exhaust ports arranged for cross-flow pattern, with valves located in "V"-type configuration, both volumetric and scavenging efficiencies are very high.
2. The combustion chamber formed between piston crown and cylinder head is of a multi-spherical type shaped to provide squish. This feature is calculated to make available greater horsepower from a lesser amount of fuel.
3. The supports for camshaft and rocker shafts are integral with the cylinder head, so that the valve mechanism noise is markedly reduced by the structural rigidity and, moreover, that the number of valve mechanism parts is reduced, let alone a more compact size of the engine.
4. The timing belt for driving the camshaft runs quiet and is light in weight.
5. A high-grade cast iron is used for the material of the cylinder block. The block is shaped to present deep skirts and retain greater rigidity.
6. The crankshaft is a one-piece forging, and is supported by five bearings for vibration free running.
7. Heating by hot water is employed for the inlet manifold in order to facilitate fuel carburetion and ensure the uniform distribution of the mixture. The higher combustion efficiency of this engine is largely explained by this inlet manifold feature.

3) Blowby gas recycling system

Blowby gas passage is provided in the cylinder block to pass the blowby gases from crankcase to cylinder head. In the head cover, an oil separator removes oil particles from the gases before the gases are drawn into the air cleaner.

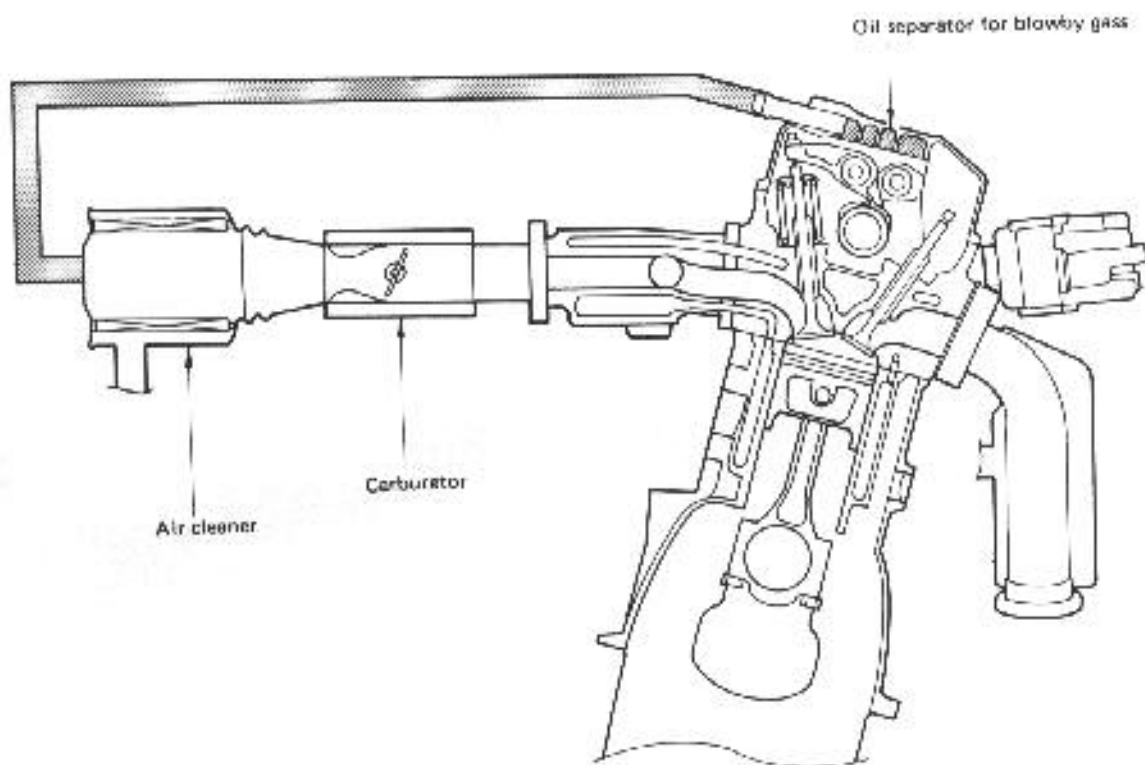

Fig. 3-2

3-2. Engine Services Not Requiring Engine Removal

The following parts or components do not require engine removal to receive services (replacement, inspection or adjustment):

Part or Component	Nature of Service
1. Spark plug	Replacement or inspection
2. Distributor	Replacement, inspection or adjustment
3. Exhaust manifold	Replacement or inspection
4. Oil filter	Replacement
5. Oil pressure unit	Replacement
6. Cylinder head cover	Replacement
7. Rocker shaft	Replacement or inspection
8. Rocker-arm	Replacement or inspection
9. Rocker arm spring	Replacement or inspection
10. Cam shaft	Replacement or inspection
11. Cylinder head	Replacement or inspection
12. Radiator	Replacement or inspection
13. Cooling fan	Replacement
14. Camshaft timing belt pulley	Replacement or inspection
15. Crankshaft timing belt pulley	Replacement or inspection
16. Timing belt	Replacement or inspection
17. Fuel pump	Replacement
18. Carburetor	Replacement, inspection or adjustment
19. Intake manifold	Replacement
20. Alternator	Replacement or inspection
21. Starter motor	Replacement or inspection
22. Fan belt	Replacement, inspection or tension adjustment
23. Water pump	Replacement
24. Pulleys (crank, generator, fan)	Replacement
25. Timing belt cover	Replacement
26. Water hose	Replacement or inspection

3-3. Dismounting the Engine

1. Loosen two drain plugs, one on the bottom of radiator and one on the cylinder block, to drain the cooling water.
2. Disconnect negative (-) and positive (+) cords from the battery terminals.
3. Remove the lower portions of shroud panel from the radiator.
4. Take down the radiator, after disconnecting the water hoses from thermostat and water inlet pipe.
5. Disconnect the accelerator wire from carburetor body.
6. Disconnect the choke wire from carburetor body.
7. Disconnect the air inlet hose from carburetor body.
8. Disconnect the water hose (leading to the car heater) from water inlet pipe.
9. Disconnect breather hose from cylinder head.
10. Disconnect the lead wire from water temperature gauge. This gauge is on the inlet manifold.
11. Disconnect the coupler and white lead wire from the alternator terminals.
12. From the starter motor terminals, disconnect black/yellow lead wire and positive (+) battery cord.
13. Disconnect water pipe from the inlet manifold.
14. From the fuel pump, disconnect two pipes leading to fuel tank.
15. Disconnect clutch cable from engine mounting.
16. Sever exhaust manifold from muffler by undoing the joint.
17. Disconnect the lead wire from oil pressure unit terminal.
18. Undo the joint between transmission and engine.
19. Pull off high-tension cord from the ignition coil.
20. Remove the nuts securing the engine mountings to make the engine ready for removal.

CAUTION:

Before starting to lift the engine check around once again to be sure that there is no connection left undone.

21. Take down the engine by operating a hoisting means.

NOTE:

To use a chain block for the hoist, take hitch on the engine at the two hooks provided, one on inlet-manifold side and one on exhaust-manifold side.

Throughout this MANUAL, the four cylinders of the engine are identified by numbers: No. 1, No. 2, No. 3 and No. 4 as counted from front end,

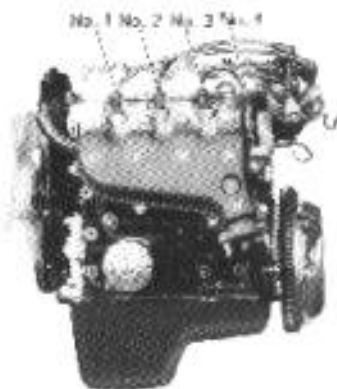

Fig. 3-3

3-4. Engine Disassembly

NOTES:

- Observe critically before starting to remove a component or part by loosening bolts, nuts and the like. What you may find before and during disassembly is valuable information necessary for successful reassembly.
- Be careful in handling aluminum-alloy parts. They are softer than steel or cast-iron parts and their finished surfaces more easily take scratch marks.
- Have trays and pans ready for setting aside the disassembled parts in an orderly manner. Place the parts in the trays and pans in such a way that they can be readily identified. Put match marks or tags on them, as necessary, so that they will go back to where they came from.

Carry out engine disassembly in the following sequence:

Loosen drain plug and drain out engine oil.

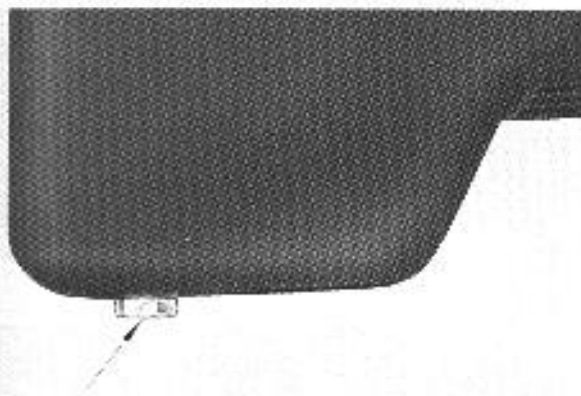

Fig. 3-4

Remove clutch cover.

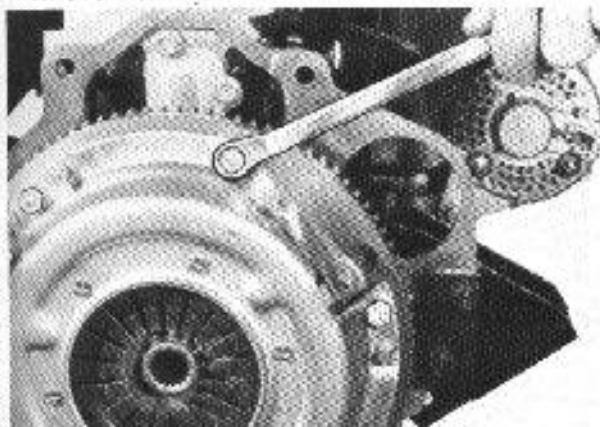

Fig. 3-5

Remove distributor assembly.

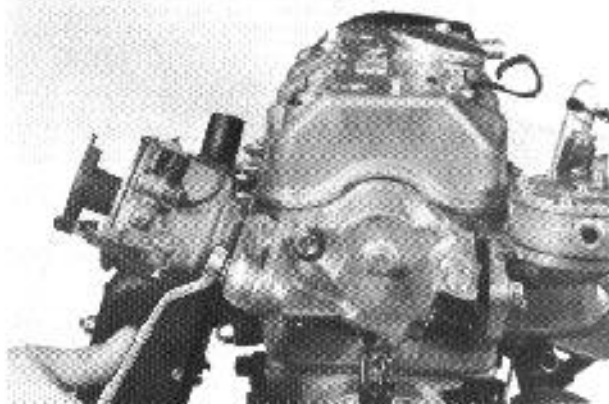

Fig. 3-6

Remove fuel pump.

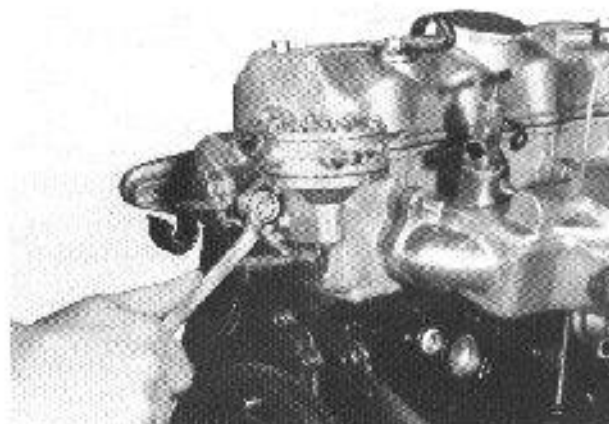

Fig. 3-7

Take down distributor case.

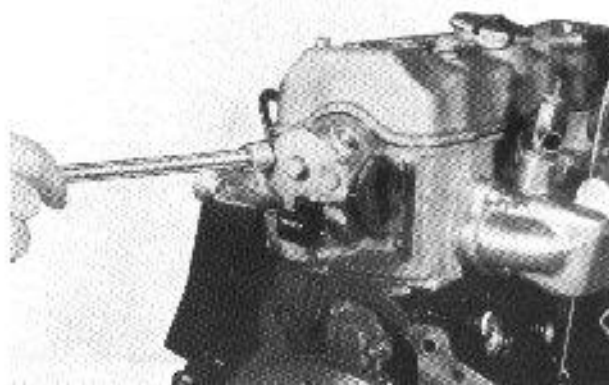

Fig. 3-8

Remove cooling fan.

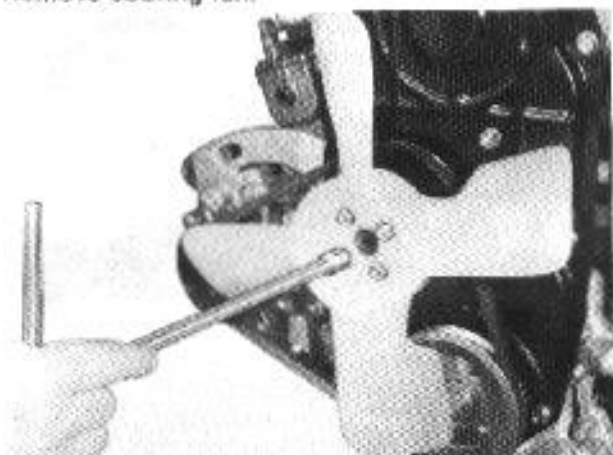

Fig. 3-9

Take down alternator.

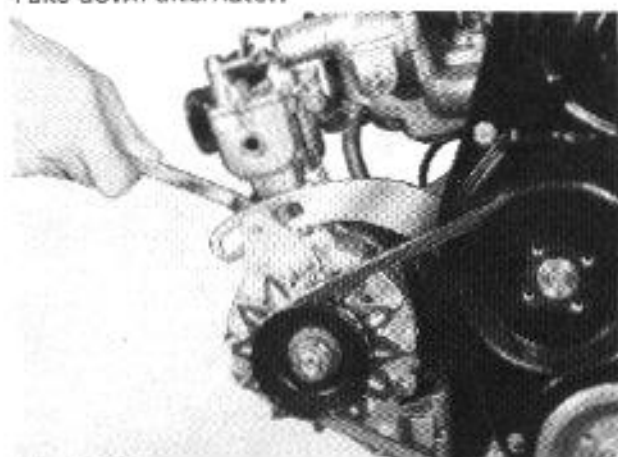

Fig. 3-10

Remove alternator mounting stay.



Fig. 3-11

Ease out water pump pulley.



Fig. 3-12

Remove crank pulley similarly, with special tool (09916-97310) hitched to flywheel so that crankshaft will not turn.

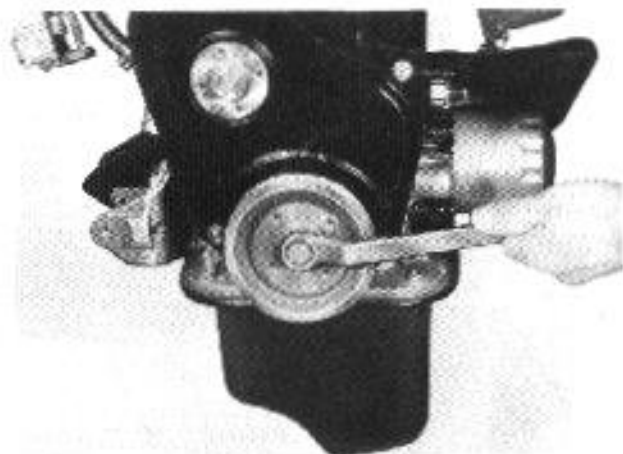

Fig. 3-13

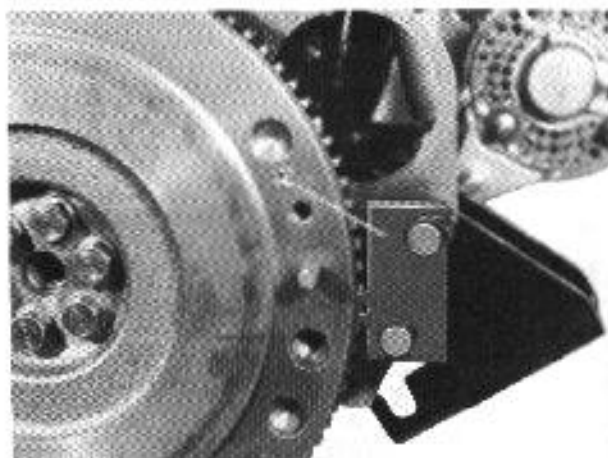

Fig. 3-14

Remove outside cover on timing belt.



Fig. 3-15

Remove timing belt tensioner.

CAUTION:

Before removing the tensioner, be sure to bring the crankshaft keyway (1) to the left side, as shown. This is necessary to avoid a piston crown hitting the valves up above. Never rotate crankshaft until cylinder head or rocker arm shafts are removed.

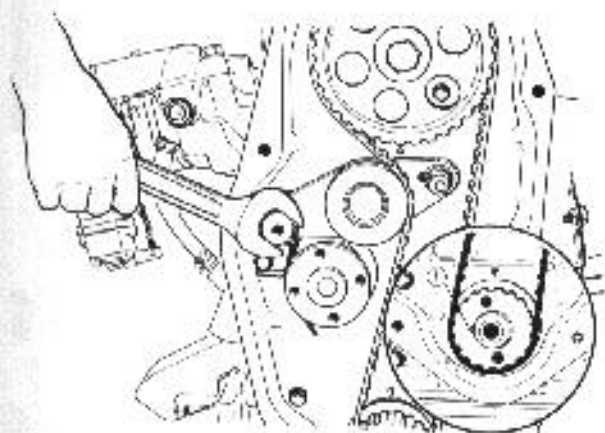

Fig. 3-16

Remove timing belt.

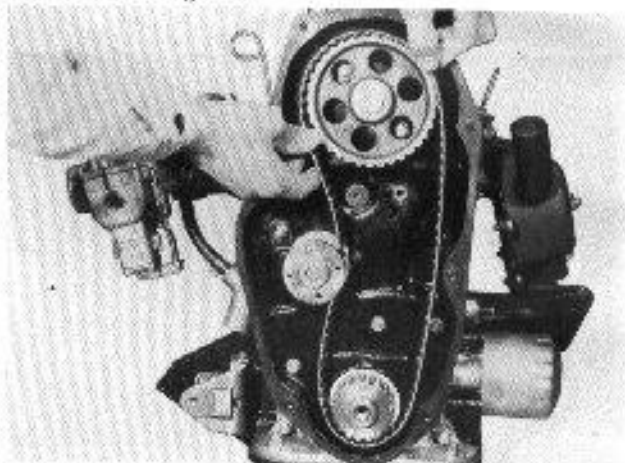

Fig. 3-17

Remove the camshaft timing belt pulley, with special tool (A) (09930-40113) attached, as shown, to lock the camshaft.

CAUTION:

Do not rotate camshaft when removing the pulley.

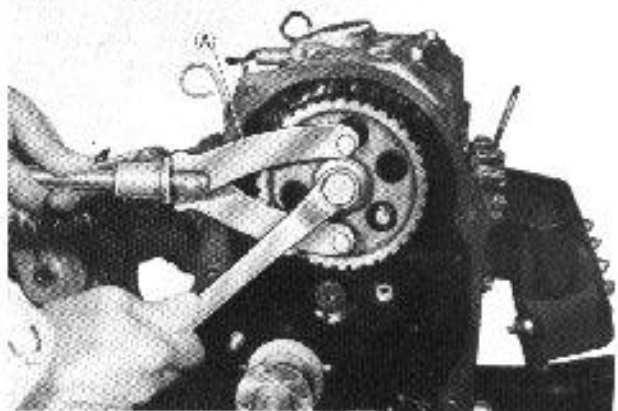

Fig. 3-18

Similarly remove the crankshaft timing belt pulley.

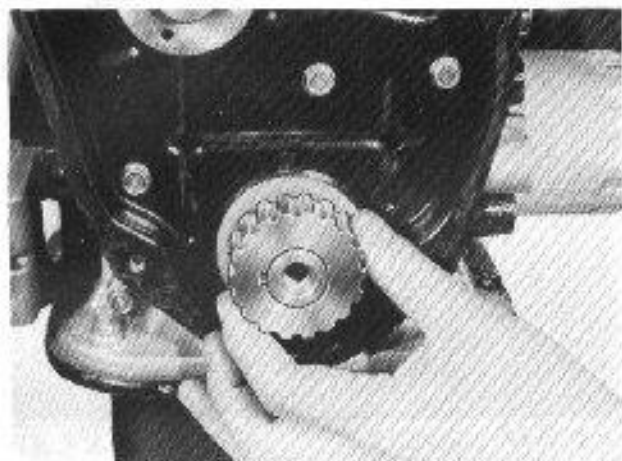

Fig. 3-19

After removing the pulley key, take out timing belt guide.

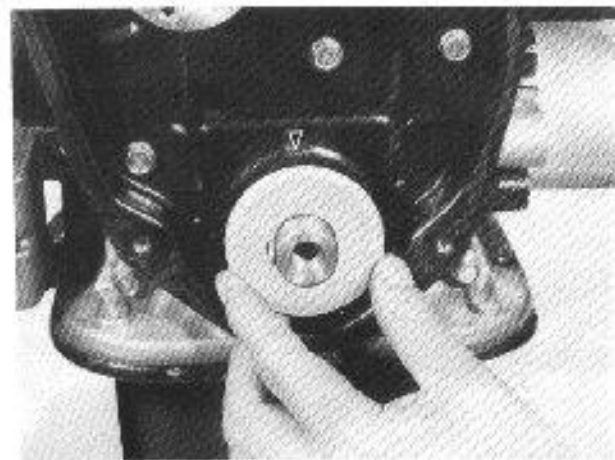

Fig. 3-20

Take down timing belt inside cover.

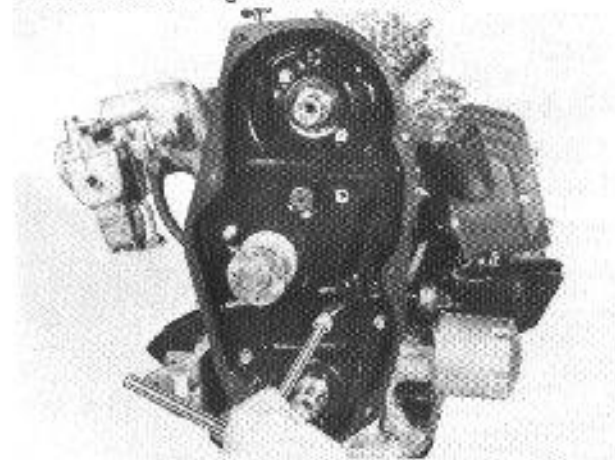

Fig. 3-21

Remove cylinder head front side case.

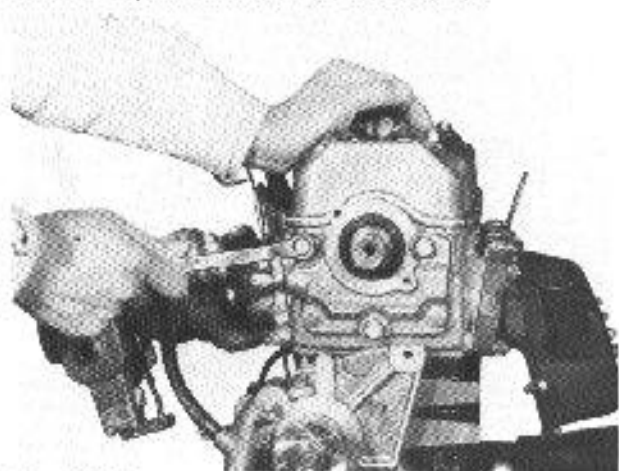

Fig. 3-22

Remove water pump case.

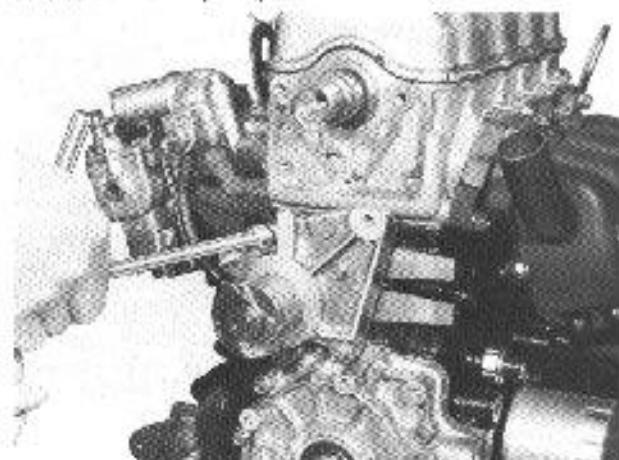

Fig. 3-23

Remove exhaust manifold cover.

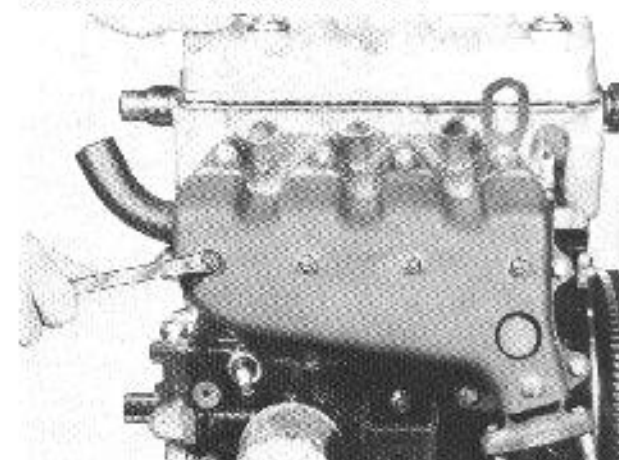

Fig. 3-24

Take off exhaust manifold and its gasket.

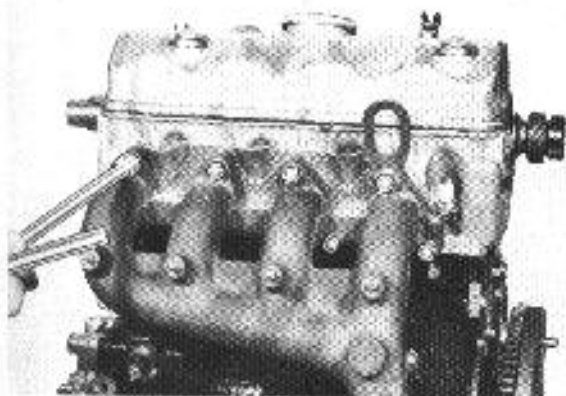

Fig. 3-25

Using special tool ① (09915-47310), remove oil filter.

NOTE:

Be careful not to spill the oil when removing the filter.

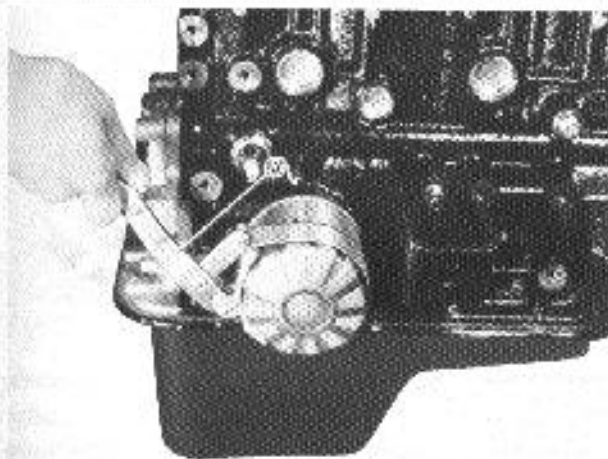

Fig. 3-26

Draw bypass hose off inlet manifold.



Fig. 3-27

Take down inlet manifold.

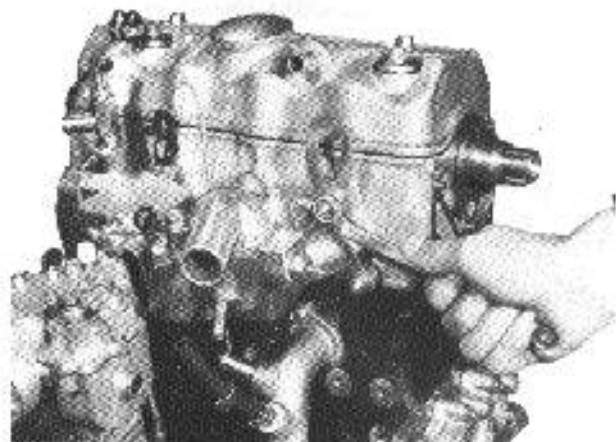

Fig. 3-28

Sever and remove water inlet pipe.



Fig. 3-29

Take off cylinder head cover.

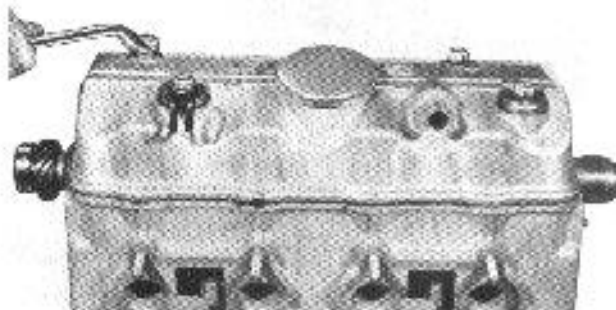

Fig. 3-30

Loosen the 8 valve adjusting screws fully. Leave the screws in place.

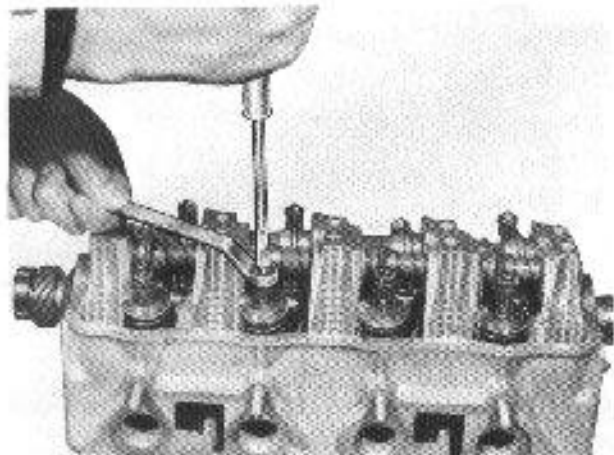

Fig. 3-31

Loosen rocker arm shaft securing screws: there are 10 screws.

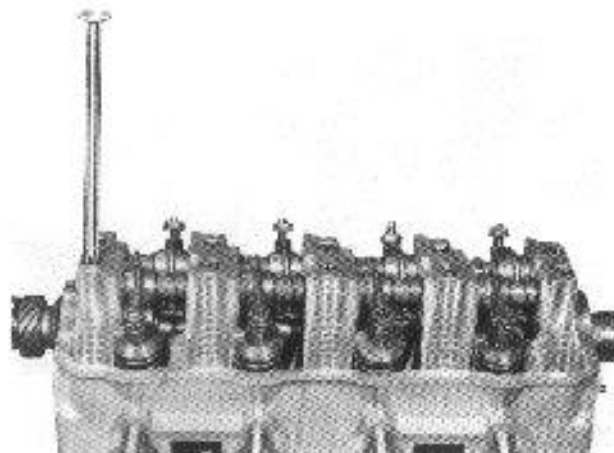

Fig. 3-32

While drawing out rocker arm shaft, separate valve rocker arms and rocker arm springs.

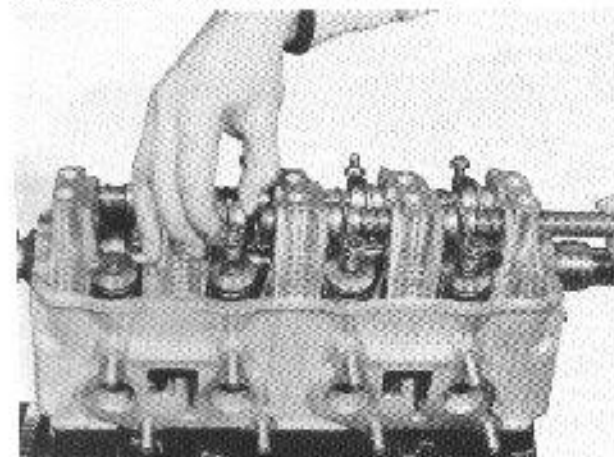

Fig. 3-33

Remove camshaft thrust plate, and draw camshaft out toward front end.

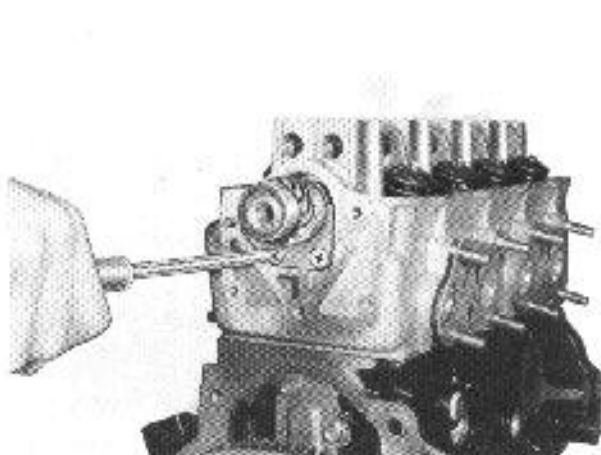

Fig. 3-34

Remove cylinder head.

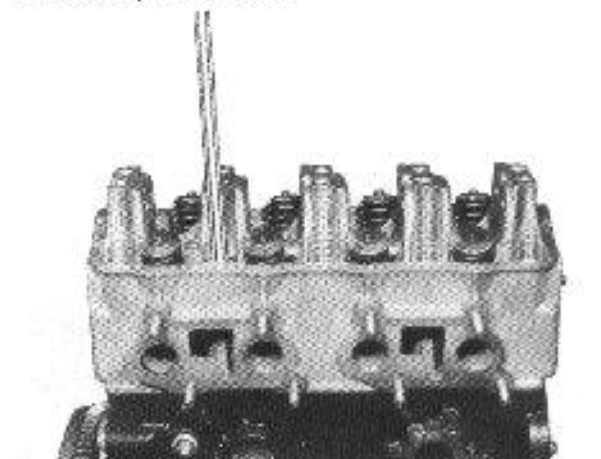

Fig. 3-35

Use valve lifter (09916-14510) to compress the valve spring in order to free valve cotter pieces for removal. In this way, remove valve spring and valves.

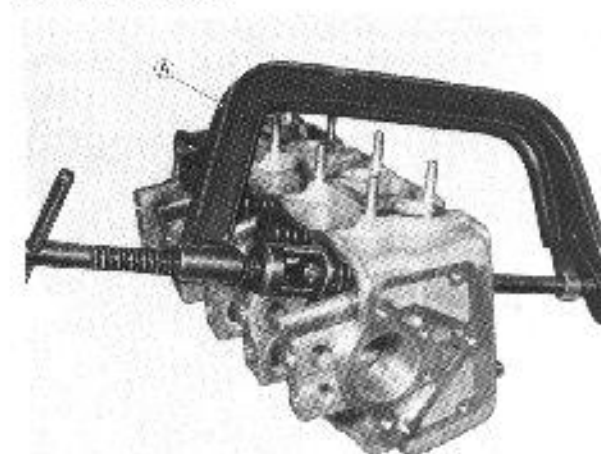

Fig. 3-36

Remove flywheel, using special tool (A) (09916-97310) as shown.

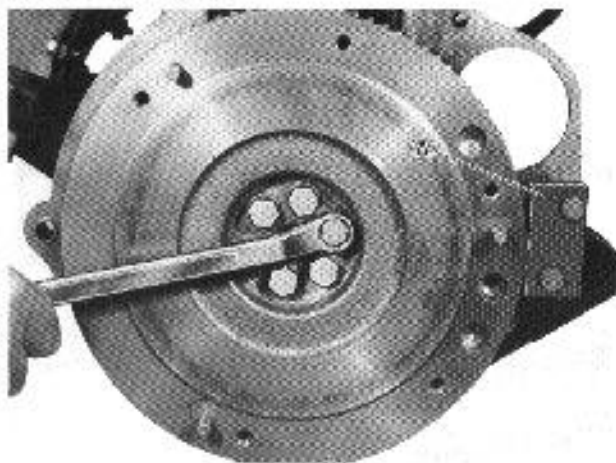

Fig. 3-37

Take down oil pan.

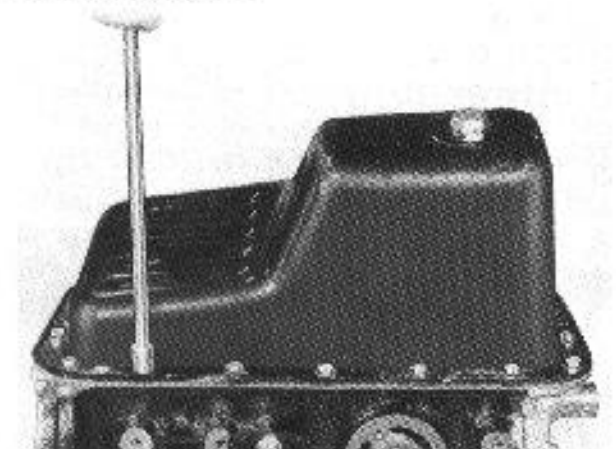

Fig. 3-38

Remove oil pump strainer.

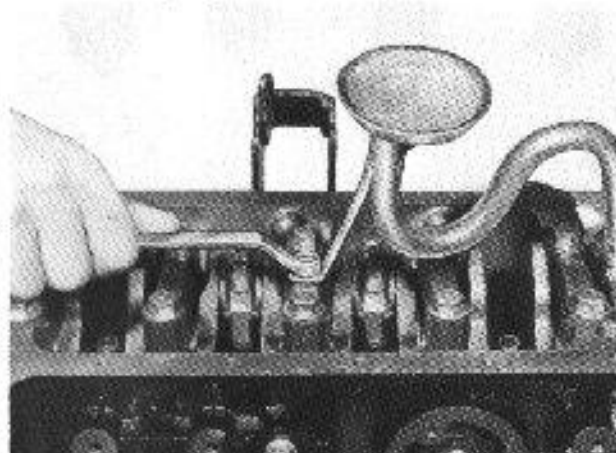

Fig. 3-39

As the first step of crankshaft removal, remove the connecting rod caps for No. 2 and No. 3 cylinders, and take out pistons, each complete with its connecting rod, from cylinder head side.

CAUTIONS:

- Before pulling the piston out, scribe the cylinder number on its crown.
- Never drive on the big end in an attempt to force the piston out. If driving is necessary to ease the big end off crankpin, run stud bolts into the big end and drive on the bolts with a mallet handle.
- Be sure to identify each bearing cap for its connecting rod by using the cylinder number. Set the cap and rod aside in combination.

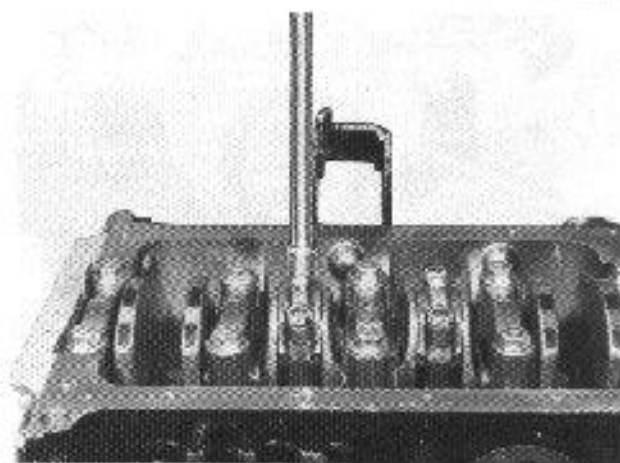

Fig. 3-40

Remove the connecting rod caps for No. 1 and No. 4 cylinders and, as mentioned above, take out the pistons and connecting rods.

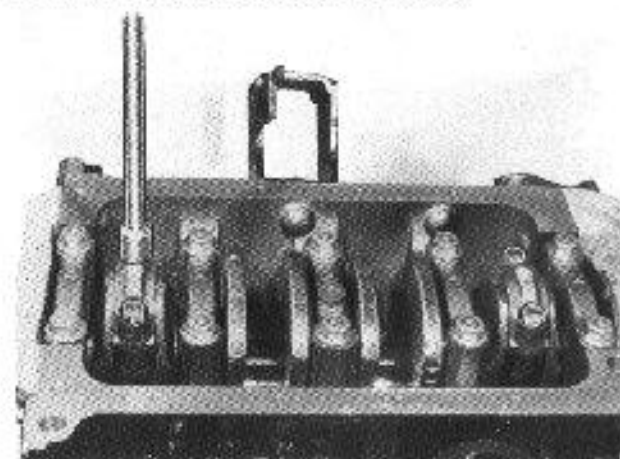

Fig. 3-41

Remove oil pump case.

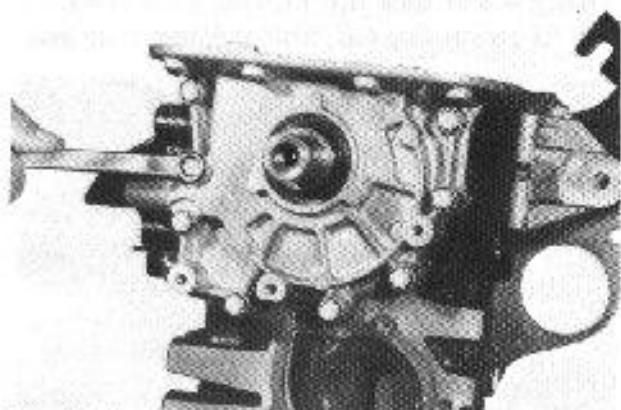

Fig. 3-42

Remove oil seal housing.

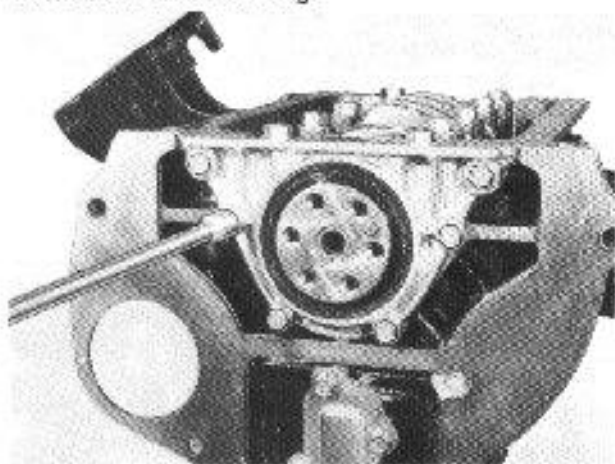

Fig. 3-43

Remove crankshaft bearing caps, and take out crankshaft.

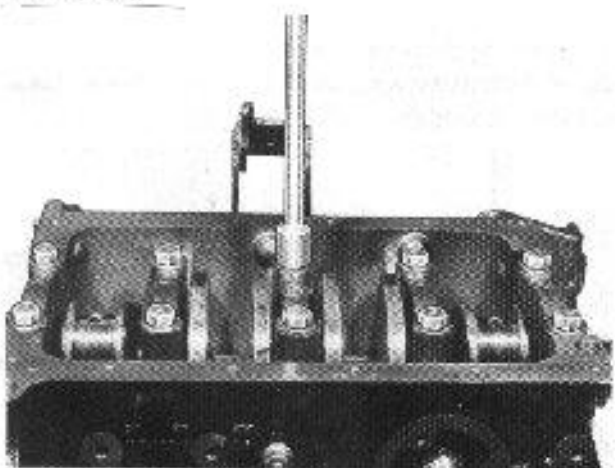

Fig. 3-44

From each piston, ease out piston pin circlips, as shown.



Fig. 3-45

Force piston pin out.

CAUTIONS:

- Before removing the pin, scribe the cylinder number on the connecting rod.
- Set the piston, piston pin and connecting rod, together with cap, in the tray or pan as a combination.

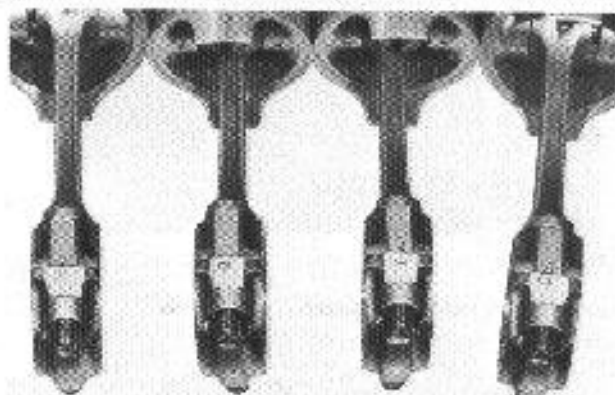

Fig. 3-46

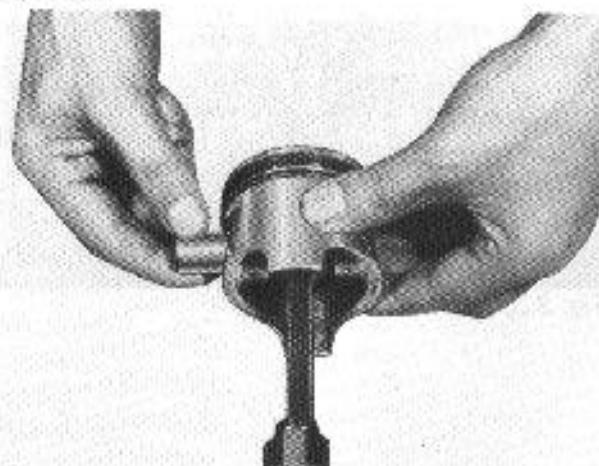

Fig. 3-47

3-5. Engine Maintenance Service

NOTES:

- During and immediately after disassembly, inspect the cylinder block and head for evidence of water leakage or damage and, after washing them clean, inspect more closely.
- Wash all disassembled parts clean, removing grease, slime, carbon and scales, before inspecting them to determine whether repair is necessary or not. Be sure to de-scale the water jackets.
- Use compressed air to clear internal oil holes and passages.
- Do not disturb the set combinations of valves, bearings and bearing caps, etc. Have the sets segregated and identified.

Cylinder head

- De-carbon the cylinder head: Deposits of carbon will be found on its combustion chamber surfaces and exhaust ports. Remember, overheating tendency and loss of output are often due to excessive carbon accumulation. De-carbon the valves, too.

NOTE:

Do not use any sharp-edged tool to scrape off the carbon. Be careful not to scuff or nick the metal surfaces when de-carboning. This applies to valves and valve seats, too.

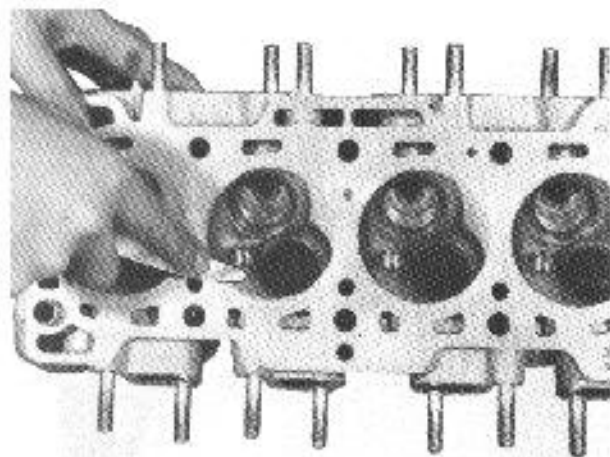

Fig. 3-48

- Flatness of gasketed surface: Using a straightedge and thickness gauge, check the flatness at a total of 7 locations. If the limit, stated below, is exceeded, correct the gasketed surface with a surface plate and sandpaper of about #400: place the sandpaper on and over the surface plate, and rub the gasketed surface against the sandpaper to grind off high spots. Should this fail to reduce the thickness gauge readings to within the limit, replace the cylinder head.

Leakage of combustion gases from this gasketed joint is often due to a warped gasketed surface; such leakage results in reduced power output and hence a higher cost of fuel per kilometer.

Limit on flatness	0,05 mm (0,002 in.)
-------------------	---------------------

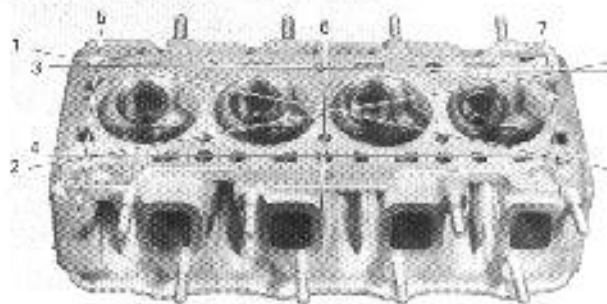

Fig. 3-49

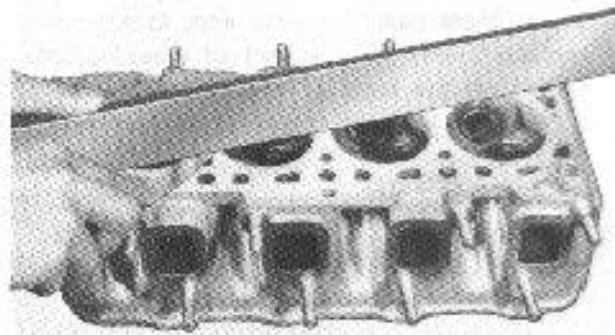

Fig. 3-50

- **Flatness of manifold seating faces:**
Check the seating faces of cylinder head for manifolds, using a straightedge and thickness gauge, in order to determine whether these faces should be corrected or the cylinder head replaced.

Limit on flatness	0.10 mm (0.004 in.)
-------------------	---------------------

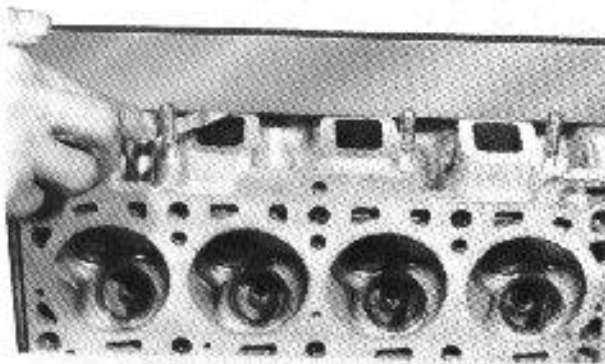

Fig. 3-51 Checking exhaust manifold seating face for flatness

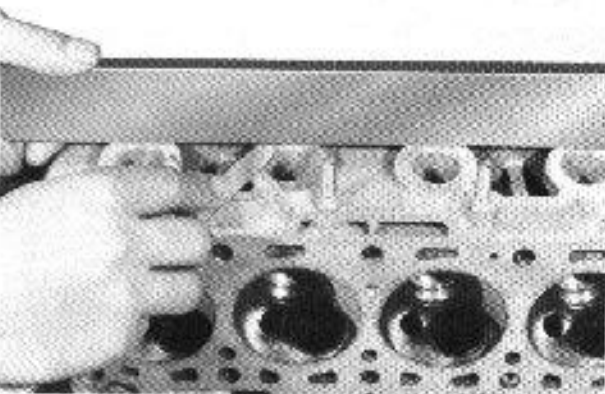

Fig. 3-52 Checking inlet manifold seating face for flatness

Rocker-arm shaft and rocker arms

- **Wear:**
Check these parts for wear and, as necessary, replace them. The extent of wear is determined on the basis of two readings, one on rocker arm I.D. and the other on shaft diameter.

NOTE:

Use a micrometer on rocker-arm shaft and a caliper on rocker arm. The difference between the two readings is the arm-to-shaft clearance on which a limit is specified. If the limit is exceeded, replace shaft or arm, or both.

Item	Standard	Limit
Rocker arm I.D.	14.985 - 15.005 mm 10.590 - 0.591 in.)
Rocker-arm shaft dia.	14.965 - 14.980 mm (0.589 - 0.590 in.)
Arm-to-shaft clearance	Inlet 0.005 - 0.040 mm (0.0002 - 0.0016 in.)	0.07 mm (0.0027 in.)
	Exhaust 0.005 - 0.040 mm (0.0002 - 0.0016 in.)	0.07 mm (0.0027 in.)



Fig. 3-53

- **Rocker-arm shaft deflection:**
Using "V" blocks and a dial gauge as shown in Fig. 3-54, check the shaft for straightness in terms of deflection. If the limit is exceeded, correct it by cold working with a wooden mallet or replace it.

Deflection limit	0.06 mm (0.0023 in.)
------------------	----------------------

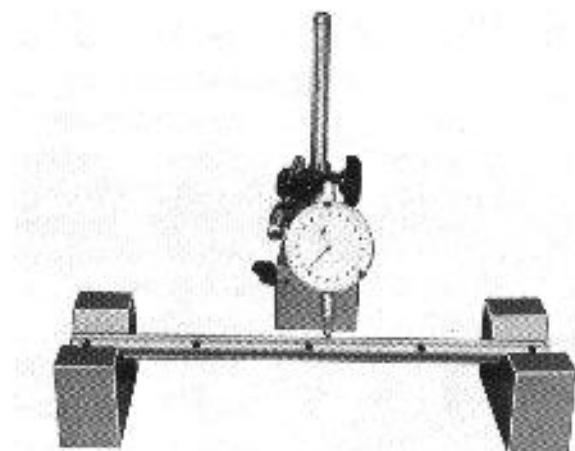

Fig. 3-54

- If the tip ① of adjusting screw ② is badly worn, replace the screw. The arm must be replaced if its cam-riding face ③ is badly worn.

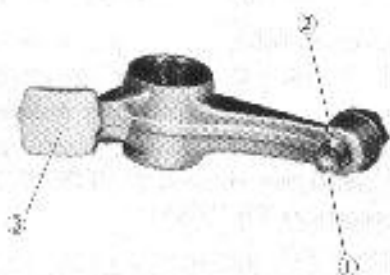

Fig. 3-55

- Visually examine each rocker-arm spring for evidence of breakage or weakening. Be sure to replace springs found in bad condition.

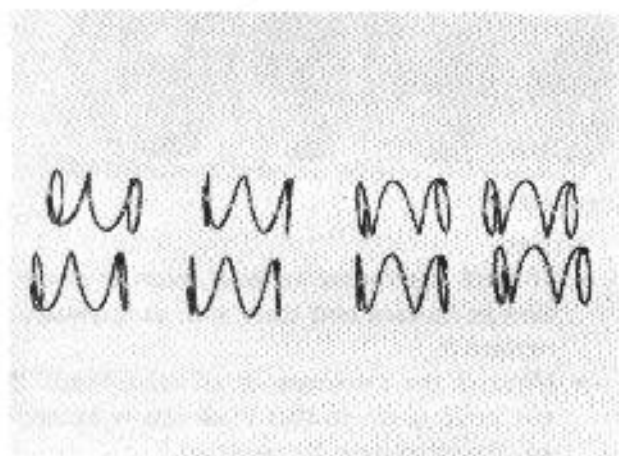

Fig. 3-56

Valve guides

- Using a micrometer and caliper, take diameter readings on valve stems and guides to determine the stem clearance in the guide. Be sure to take a reading at more than one place along the length of each stem and guide, as shown in Fig. 3-57.

Item		Standard	Limit
Valve stem diameter	Inlet	6.965 - 6.980 mm (0.2742 - 0.2748 in.)	---
	Exhaust	6.955 - 6.970 mm (0.2738 - 0.2744 in.)	---
Valve guide I.D.	Inlet	7.000 - 7.015 mm (0.2755 - 0.2761 in.)	---
	Exhaust	7.000 - 7.015 mm (0.2755 - 0.2761 in.)	---
Stem-to-guide clearance	Inlet	0.020 - 0.050 mm (0.0008 - 0.0019 in.)	0.07 mm (0.0027 in.)
	Exhaust	0.030 - 0.060 mm (0.0012 - 0.0023 in.)	0.09 mm (0.0035 in.)

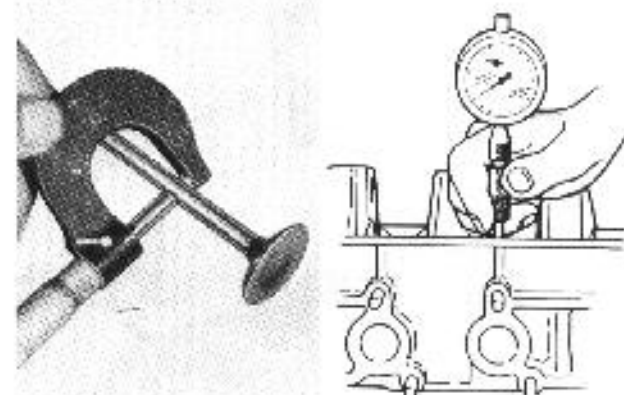

Fig. 3-57

If the caliper like the one shown in Fig. 3-57 is not available, check the end deflection of the valve stem in place with a dial gauge rigged as shown in Fig. 3-58. Move the stem end in the directions ④ ⑤ and determine whether replacement is necessary or not, by referring to these limiting values:

Valve stem and deflection	Inlet	0.12 mm (0.0047 in.)
	Exhaust	0.16 mm (0.0063 in.)

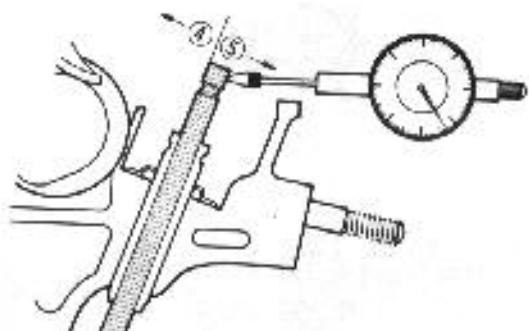

Fig. 3-58

● **Valve guide replacement:**

Valve guides are shrink-fitted. The method of removal and installation is as follows:

- 1) Using the guide remover (A) (09916-44510), drive the valve guide out to remove it from the top side of cylinder head. After driving the guide out, ream the guide hole with a 12 mm (0.472 in.) reamer (Special tool 09916-37310) to remove burrs, making sure that the hole diameter after reaming comes within this range:

Valve guide hole diameter	Inlet	12.030 - 12.048 mm (0.4736 - 0.4743 in.)
	Exhaust	

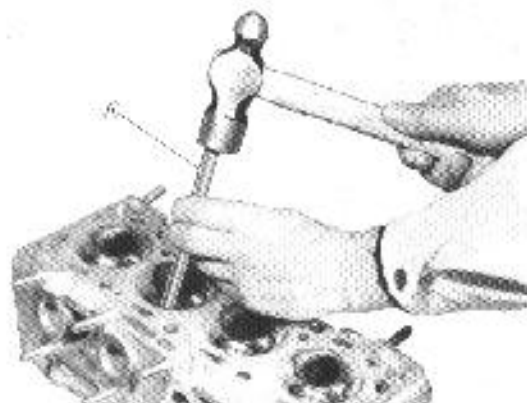

Fig. 3-59

- 2) Heat the cylinder head uniformly to any where between 80°C and 100°C (176°F-212°F) so that the head will not distort, and drive the oversize guide into the hole with the valve guide installer set (B) (09916-57310 and 09916-57320). See Fig. 3-60. Be sure to carry out this step speedily so that all guides will go into the cylinder head in steady temperature state.

Valve guide oversize	0.03 mm (0.0012 in.)
Valve guide protrusion (C)	16.5 mm (0.649 in.)

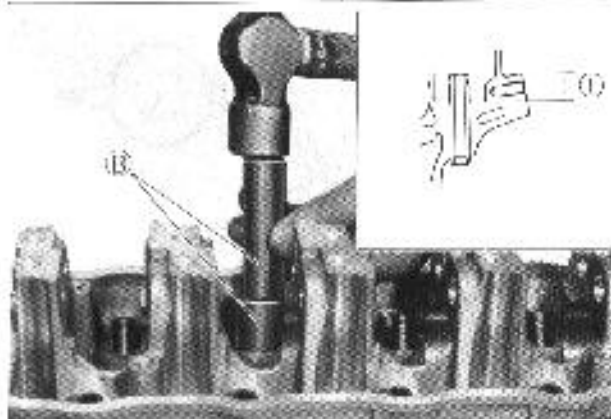

Fig. 3-60

NOTE:

Valve guide length differs between INLET and EXHAUST. It is 52.5 mm (2.067 in.) for INLET but 54.5 mm (2.145 in.) for EXHAUST.

- 3) Check all valve guides in place for I.D. and, if the I.D. reading compared with the stem diameter reading indicates too small a radial clearance, ream the guide I.D. with the reamer (C) (09916-34520), as shown in Fig. 3-61.

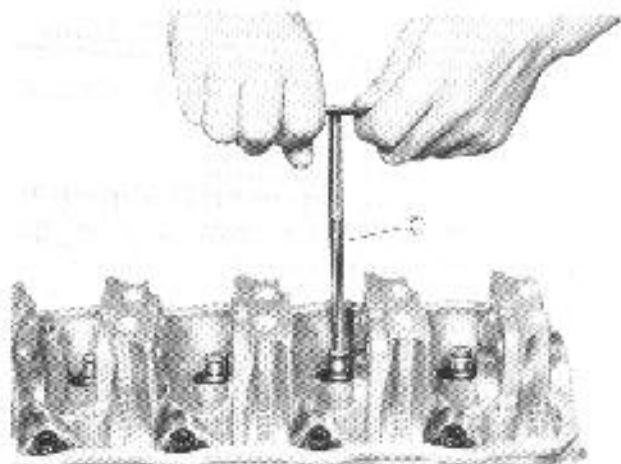

Fig. 3-61

Valves

- Inspect each valve for wear, burn or distortion at its face and stem and, as necessary, replace it.
- Measure the thickness (D) of valve head. If the limit given to this thickness is exceeded, the valve must be replaced.

Valve head thickness (D):

Standard	Limit	
0.8 - 1.2 mm (0.031 - 0.047 in.)	Inlet	0.8 mm (0.0236 in.)
	Exhaust	0.7 mm (0.0275 in.)

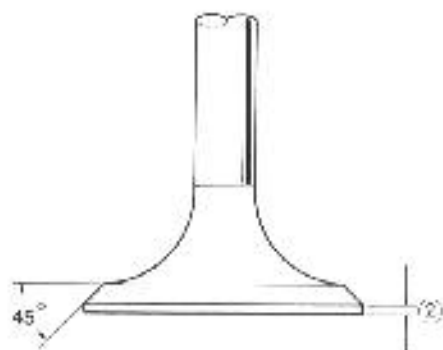

Fig. 3-62

- Check the end face of each valve stem for wear. This face meets the rocker arm intermittently in operation, and might become concaved or otherwise irregular. As necessary, smoothen the end face with an oil stone and, if this grinding removes the end stock by as much as 0.5 mm (0.0196 in.) (as measured from the original face), replace the valve.

Limit on stock allowance of valve stem end face	0.5 mm (0.0196 in.)
---	---------------------

Replacement valves have their stems machined to the following diameter ranges.

Standard valve stem diameter	Inlet	6.965 - 6.980 mm (0.2742 - 0.2748 in.)
	Exhaust	6.955 - 6.970 mm (0.2738 - 0.2744 in.)

- Check each valve for radial runout with a dial gauge and "V" block, as shown in Fig. 3-63. The object of this check is to determine whether the valve stem is true and square relative to the head.

Limit on valve head radial runout	0.03 mm (0.0012 in.)
-----------------------------------	----------------------

If the limit is exceeded, do not attempt to correct the stem; replace the valve, instead.

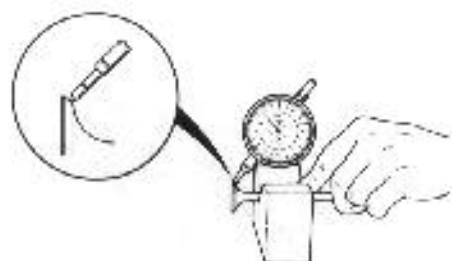

Fig. 3-63

Valve seats

CAUTION:

The valves to be checked and serviced for seating width and contact pattern must be those found satisfactory in regard to stem clearance in the guide and also the requirements stated in the preceding part titled VALVES.

- Seating contact width:

Produce a contact pattern on each valve in the usual manner, namely, by giving a uniform coat of red-lead paste to the valve seat and by rotatingly tapping the seat with the valve head. The valve lapper (the tool used in valve lapping) must be used.

The pattern produced on the seating face of the valve must be a continuous ring without any break, and the width (W) of the pattern must be within the stated range.

Standard seating width (W) revealed by contact pattern on valve face	Intake	1.3 - 1.5 mm (0.0512 - 0.0590 in.)
	Exhaust	

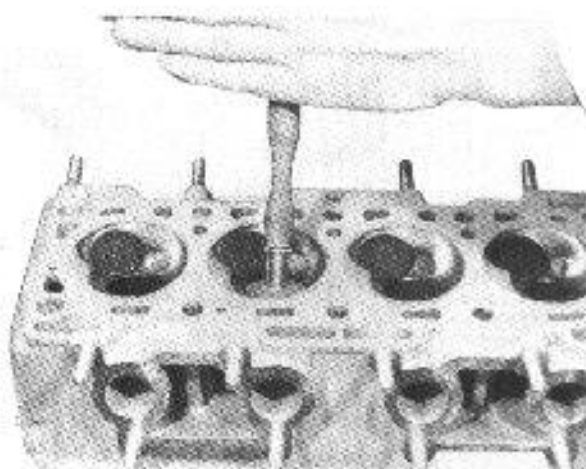

Fig. 3-64

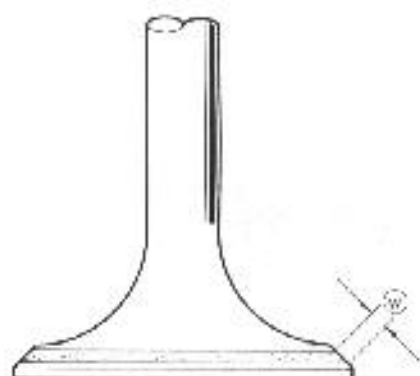

Fig. 3-65

• Valve seat repair:

A valve seat not producing a uniform contact with its valve or showing a width \textcircled{w} of the seating contact that is off the specified range must be repaired by regrinding or by cutting and regrinding and finished by lapping.

1) EXHAUST VALVE SEAT: Use a valve seat cutter to make three cuts in the order illustrated in Fig. 3-67. Three cutters must be used: the first for making the 15° angle, the second for making the 75° angle and the last for making the 45° seat angle. The third cut $\textcircled{3}$ must be made to produce the desired seat width \textcircled{w}

Seat width \textcircled{w} for exhaust valve seat	1.3 - 1.5 mm (0.0512 - 0.0590 in.)
---	---------------------------------------

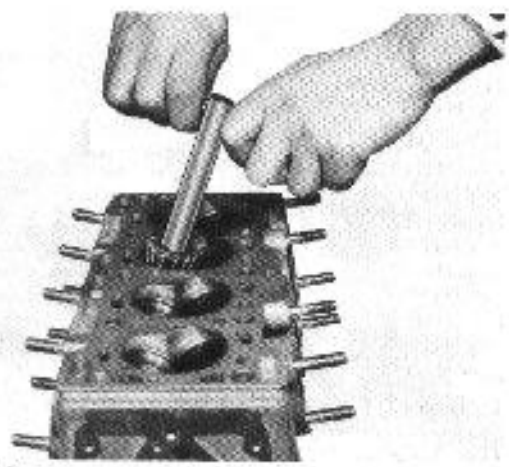

Fig. 3-66 Valve seat cutting

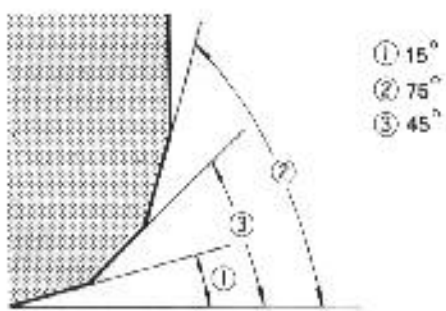

Fig. 3-67 Valve seat angles for exhaust valve seat

2) INLET VALVE SEAT: The cutting sequence is the same as for exhaust valve seats but the second angle differs, as will be noted in Fig. 3-68.

Seat width \textcircled{w} for inlet valve seat	1.3 - 1.5 mm (0.0512 - 0.0590 in.)
---	---------------------------------------

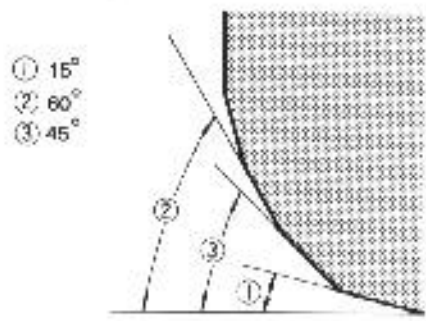

Fig. 3-68 Valve seat angles for inlet valve seat

3) VALVE LAPPING: Lap the valve on the seat in two steps, first with a coarse size lapping compound applied to the face and the second with a fine size compound, each time using a valve lapper according to the usual lapping method.



Fig. 3-69 Applying lapping compound to valve face

NOTES:

- After lapping, wipe the compound off the valve face and seat, and produce a contact pattern with a red lead paste. Check to be sure that the contact is centered widthwise on the valve seat and that there is no break in the contact pattern ring.
- Be sure to check and, as necessary, adjust the valve clearance after re-installing the cylinder head and valve mechanism.

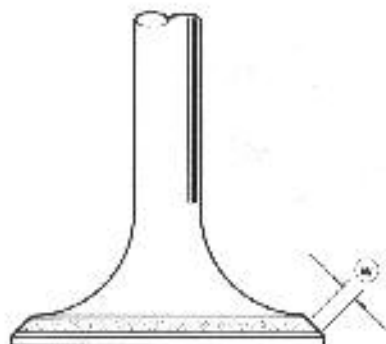

Fig. 3-70 Contact pattern @ uniform in width

Valve springs

- Referring to the criterion data given below, check to be sure that each spring is in sound condition, free of any evidence of breakage or weakening. Remember, weakened valve springs can be the cause of chatter, not to mention the possibility of reducing the power output due to gas leakage caused by decreased seating pressure.

Item	Standard	Limit
Valve spring free length	47.7 mm (1.8779 in.)	46.5 mm (1.8307 in.)
Valve spring preload	26 - 30 kg for 40 mm (57.3 - 66.1 lb/ 1.57 in.)	24 kg for 40 mm (52.9 lb/ 1.57 in.)

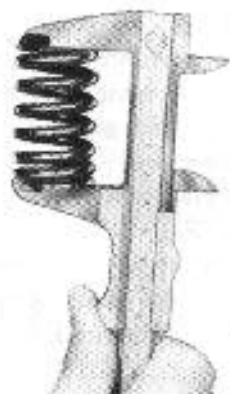

Fig. 3-71 Measuring free length of spring



Fig. 3-72 Checking the spring for preload

- Spring squareness:
Use a square and surface plate to check each spring for squareness in terms of the clearance ①, Fig. 3-73, between the end of valve spring and the square. Valve springs found to exhibit a larger clearance than the limit must be replaced.

Valve spring squareness ①	2.0 mm (0.079 in.)
---------------------------	-----------------------

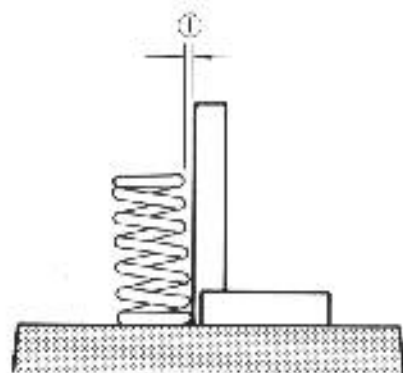

Fig. 3-73

3-6. Engine Reassembly

NOTE:

- All parts to be used in reassembly must be perfectly clean.
- Oil the sliding and rubbing surfaces of engine parts just before using them in reassembly. Use engine oil (Refer to page 22).
- Have the liquid packing ready for use. SUZUKI BOND No. 4 is specified for the liquid. Use it wherever its use is specified in order to ensure leak-free (oil and water) workmanship of reassembly.
- There are many running clearances. During the course of engine reassembly, be sure to check these clearances, one after another, as they form.
- Gaskets, "O" rings and similar sealing members must be in perfect condition. For these members, use replacement parts in stock.
- Tightening torque is specified for important fasteners—bolts and nuts in the main—of the engine and other components. Use torque wrenches and constantly refer to the specified values given in the text of this manual. The list immediately following is such specifications.
- Do not disregard the match marks provided on parts. Some of them are those given at the time of disassembly.
- There are many sets of parts. Crankshaft bearings, connecting rods, pistons, etc., are in combination sets. Do not disturb the combinations and try to see that each part goes back to where it came from.

Tightening torque data

This is a list-up of important tightening jobs identified by parts to be secured:

What to tighten	kg-m	lb-ft
Crankshaft bearing cap bolt	4.3 - 4.8	31.5 - 34.5
Connecting-rod bearing nut	2.8 - 3.2	20.5 - 23.0
Crankshaft pulley bolt	5.0 - 6.0	36.5 - 43.0
Flywheel bolt	4.0 - 4.5	29.0 - 32.5
Cylinder head bolt	5.5 - 6.0	40.0 - 43.0
Spark plug	2.0 - 3.0	14.5 - 21.5
Camshaft pulley bolt	5.0 - 6.0	36.5 - 43.0
Valve adjusting nut	1.5 - 2.0	11.0 - 14.0

What to tighten	kg-m	lb-ft
Oil drain plug	2.0 - 2.5	14.5 - 18.0
Oil pan securing bolt	0.4 - 0.5	3.0 - 3.5
Oil filter	1.0 - 1.5	7.5 - 10.5
Oil filter stand	2.0 - 2.9	14.5 - 18.0
Oil pressure unit	1.2 - 1.5	9.0 - 10.5
Timing belt cover bolt	0.3 - 0.4	2.5
Cylinder head cover bolt	0.3 - 0.7	2.0 - 5.0

Engine reassembly is the reverse of engine disassembly as far as sequence is concerned, but there are many reassembling steps that involve measures necessary for restoring the engine as close to the factory-assembled condition as possible. Only those steps will be dealt with.

Crankshaft

Be sure to oil crankshaft journal bearings as shown.

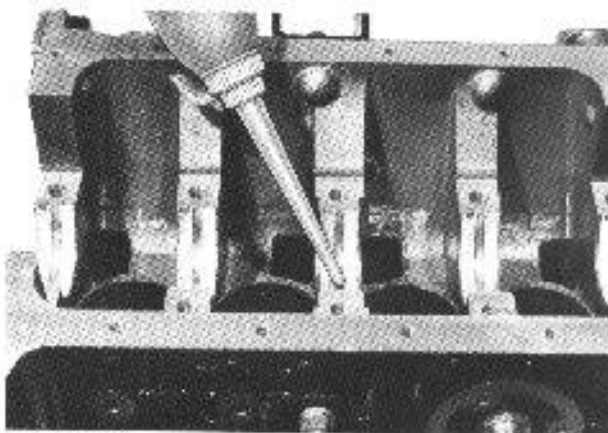

Fig. 3-99

Thrust bearings for the crankshaft are an item prone to escape the serviceman's attention: be careful not to leave them out. These bearings go into place with their oil groove side facing the crank web.

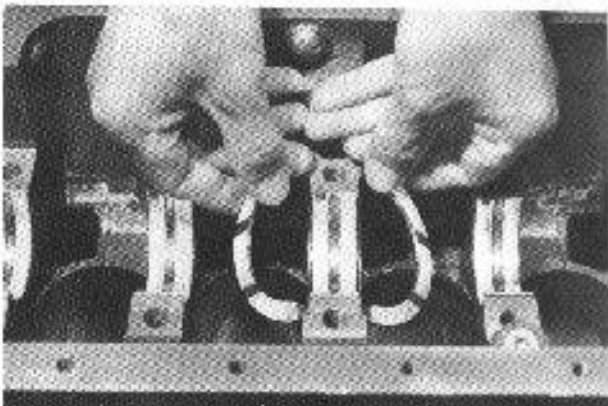

Fig. 3-100

Be sure to oil crankshaft journals as shown.

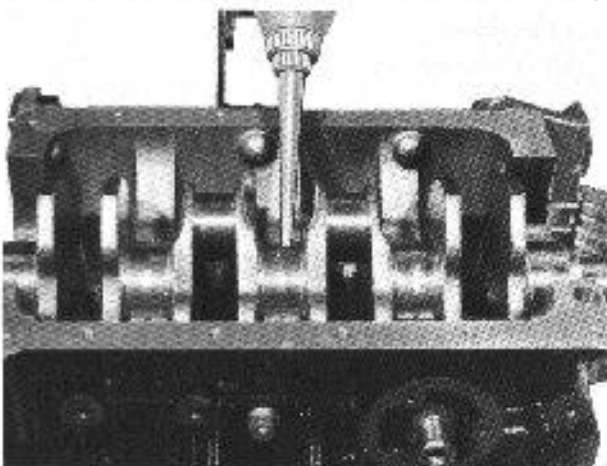

Fig. 3-101

When fitting crankshaft bearing caps to journals after setting the crankshaft in place, be sure to point the arrow mark (on each cap) to front side. Fit them sequentially in the ascending order, 1, 2, 3, 4 and 5, starting from front (pulley) side.

Tightening torque for bearing cap bolts	4.3 - 4.8 kg-m (31.5 - 34.5 lb-ft)
--	---------------------------------------

Gradual and uniform tightening is important for bearing cap bolts. Make sure that the five caps become tight equally and uniformly progressively to the stated torque value.

NOTE:

After tightening cap bolts, check to be sure that crankshaft rotates smoothly when turned over by hand.

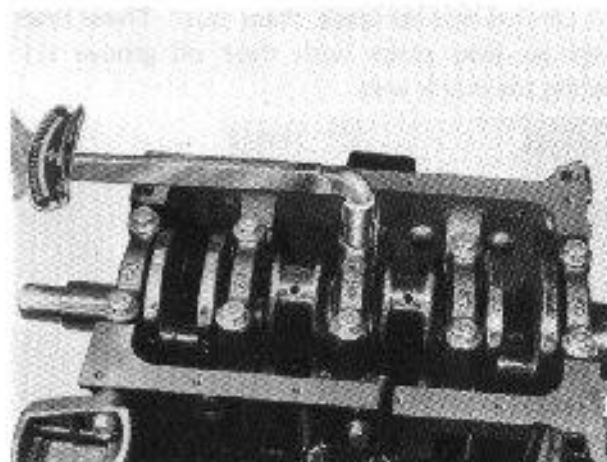

Fig. 3-102

Oil seal housing

This housing demands a new gasket: do not re-use the gasket removed in disassembly. After bolting the housing to the block, the gasket edges might bulge out; if so, cut off the edges to make the joint seam flat and smooth: use a sharp knife. After cutting, apply SUZUKI BOND No. 4, as shown.

NOTE:

Just before mounting the housing, oil the lip portion of the oil seal.

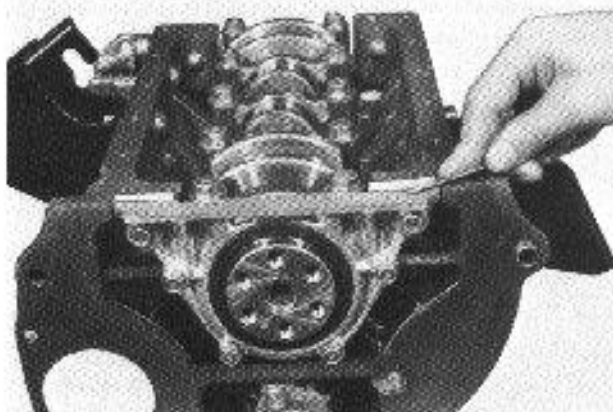

Fig. 3-103

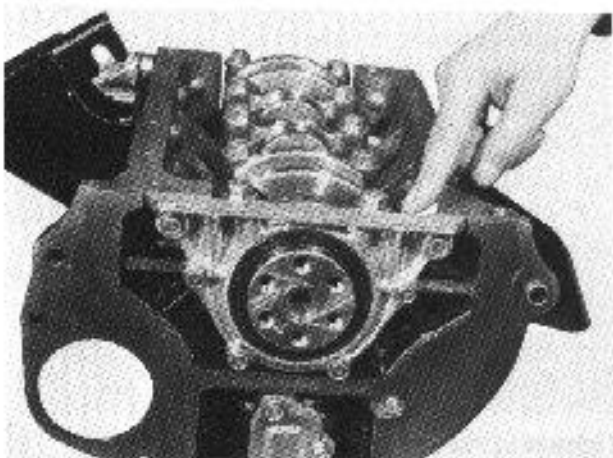

Fig. 3-104

Oil pump

The gasket for oil pump case must be new. As in the case of oil seal housing, cut off the gasket edges with a knife to smoothen the joint seam.

NOTE:

Before fitting the pump case, oil the oil seal lip.

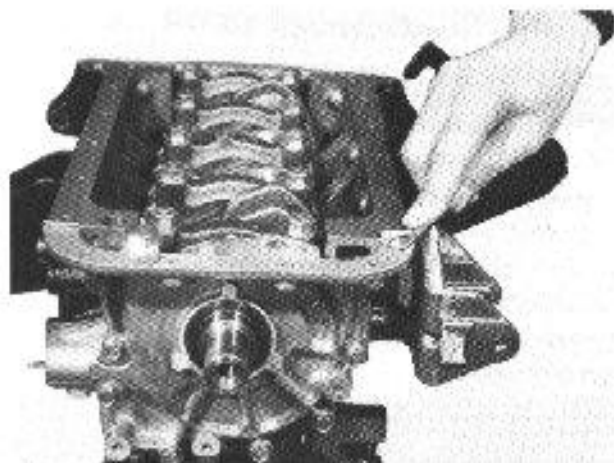

Fig. 3-105

After cutting the gasket edges, apply SUZUKI BOND No. 4.

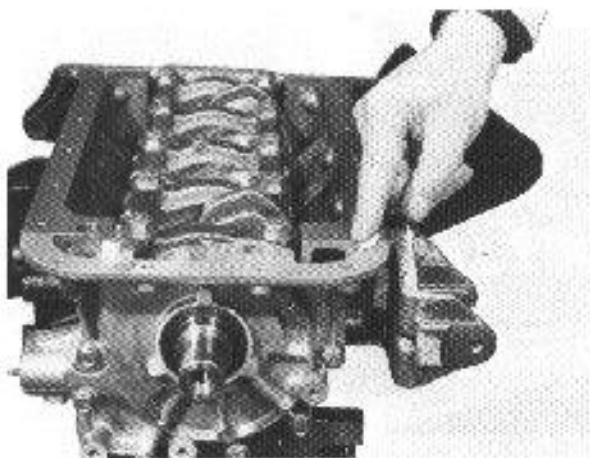

Fig. 3-106

Piston and piston rings

POSITION OF PISTON RELATIVE TO CONNECTING ROD: The arrow ① on the crown points to front (pulley) side, and the oil hole ② comes on inlet port side. See Fig. 3-107.

NOTE:

Before pinning piston to connecting rod, oil the small end and pin holes.

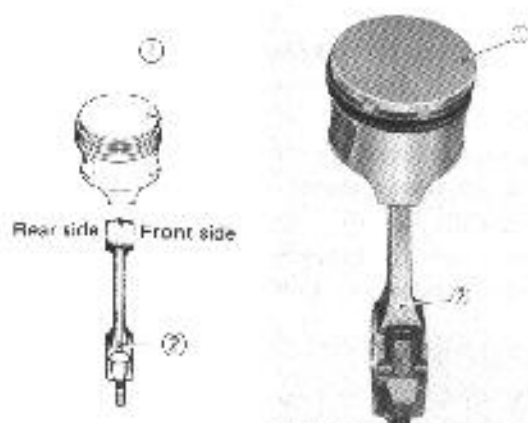

Fig. 3-107

Before fitting rings to piston, check to be sure that first ring has RN mark and second ring R mark. After mounting the three rings, distribute their end gaps as illustrated in Fig. 3-108. Remember, the marked side of each ring (1st and 2nd) comes on top side.

NOTE:

After fitting the rings, oil them in the grooves.

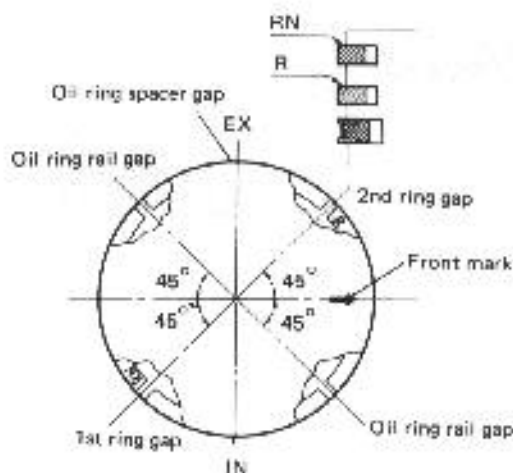

Fig. 3-108

Use of the piston ring compressor (A) (09916-77310), Fig. 3-109, is mandatory in inserting pistons into cylinder block. Using this compressor (A), feed the piston and connecting rod combination into the bore from the gasketed surface side of block, starting with No. 1 and No. 4 cylinders, while the crankshaft in place is so turned as to hold No. 1 and No. 4 crankpins at bottom dead center. Install No. 2 and No. 3 combinations similarly.

Pay attention to these reminders:

- Point the piston crown arrow to front side.
- Be sure that the number (marked on the crown at the time of disassembly) tallies with the cylinder number.
- Liberally oil the big-end bearings before fitting them to crankpins.
- Oil the bore just before feeding in the piston.

CAUTION:

As the piston and connecting rod combination goes into the bore, the rod might hitch onto the cylinder wall or crank journal. In such a case, do not attempt to force piston in. If any hitch is felt, look into under crankshaft to clear the way for the rod.



Fig. 3-109

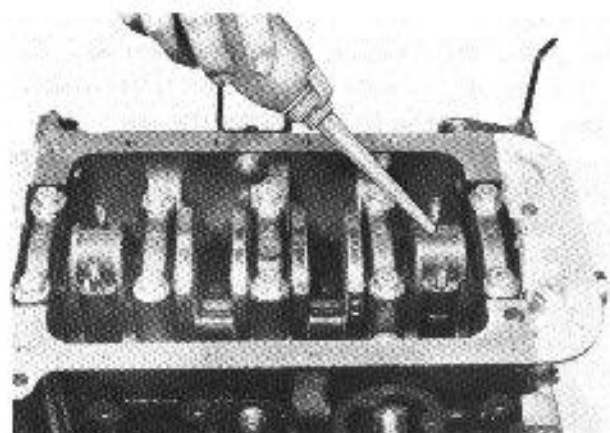

Fig. 3-110

Connecting rods

Two stoppers (1) (2), Fig. 3-112, determine the position of each big-end bearing cap relative to the big end. At the time of installing these caps, be sure to locate stopper (1) of cap in the direction of stopper (2).

NOTE:

The two stoppers do not coincide in longitudinal direction: the coincidence is meant in the direction shown in Figs. 3-111 and Fig. 3-112.

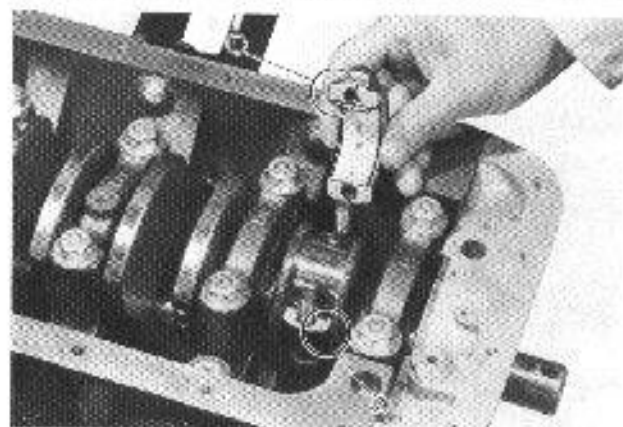

Fig. 3-111

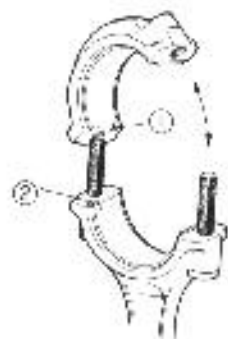

Fig. 3-112

After fitting all four big-end bearing caps, start tightening them uniformly, being sure to equalize tightness between right and left on each cap. The sequence here is similar to that for crankshaft bearing caps.

Tightening torque for big-end caps	2.8 - 3.2 kg-m (20.5 - 23.0 lb-ft)
------------------------------------	---------------------------------------

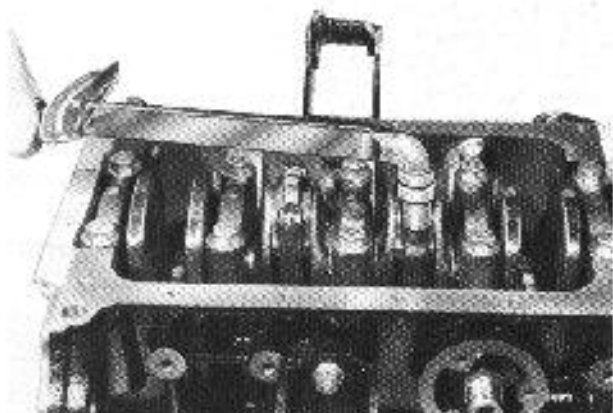

Fig. 3-113

NOTE:

After installing crankshaft and pistons, as above, double-check to be sure that the arrows on piston crowns are all pointing to pulley (front) side.

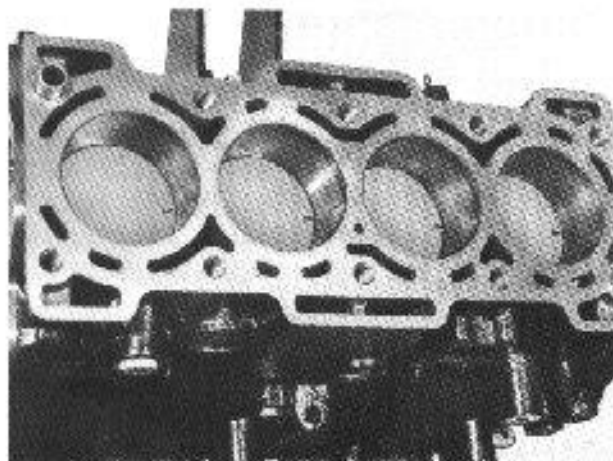

Fig. 3-114

Oil pump strainer

Bear in mind that "O" ring ① is often forgotten and left out in reassembly. Absence of this ring defeats the purpose served by the strainer.



Fig. 3-115

When installing the strainer, be sure to tighten bolts ② first.

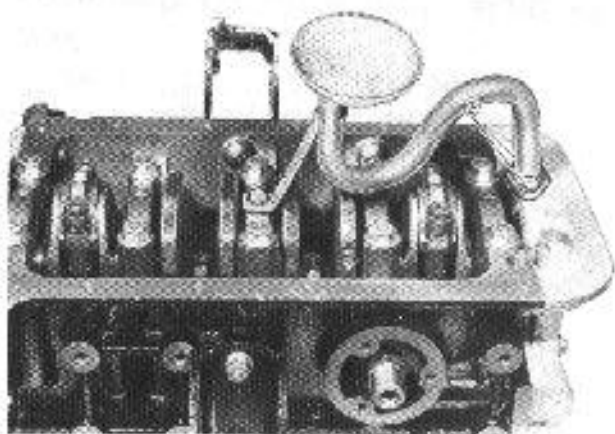

Fig. 3-116

Oil pan

After fitting the oil pan to the block, run in the securing bolts and start tightening at the center: move the wrench outward, tightening one bolt at a time.

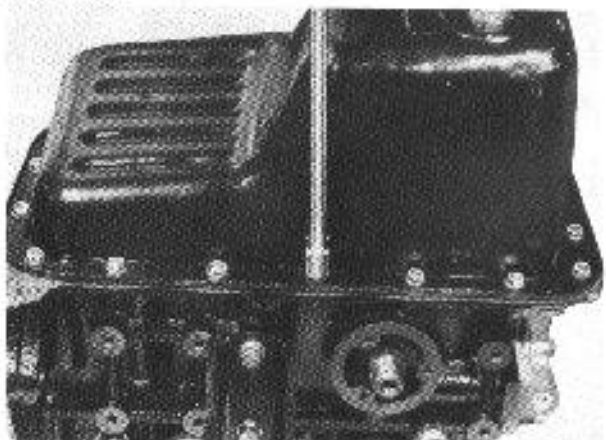

Fig. 3-117

Flywheel

The first step of flywheel installation is to check to be sure that locating pin ① is studded in the crankshaft. The next step is to fill up the pocket between input shaft bearing and oil seal ② with grease (SUZUKI SUPER GREASE A). Make this pocket 60% full.

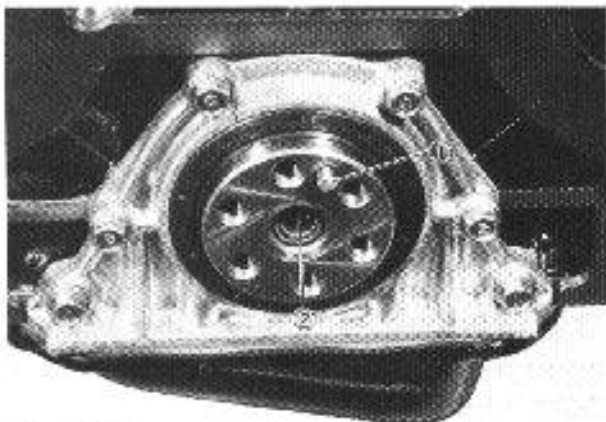

Fig. 3-118

Cylinder head

Oil valve stems before inserting them into guides.

CAUTION:

Be sure to distinguish between inlet valves and exhaust valves. The difference is in diameter and marking. Refer to the embossed marks, shown in Fig. 3-119.

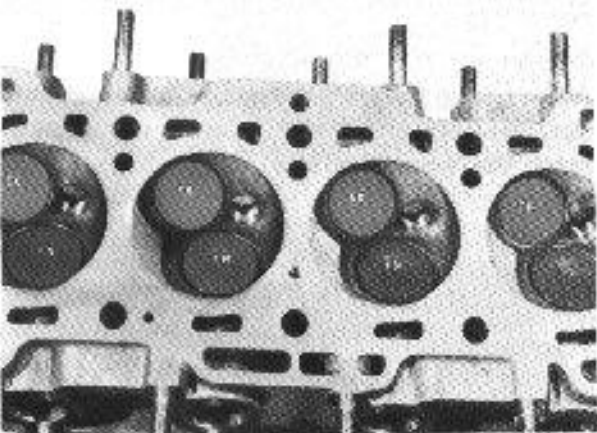

Fig. 3-119

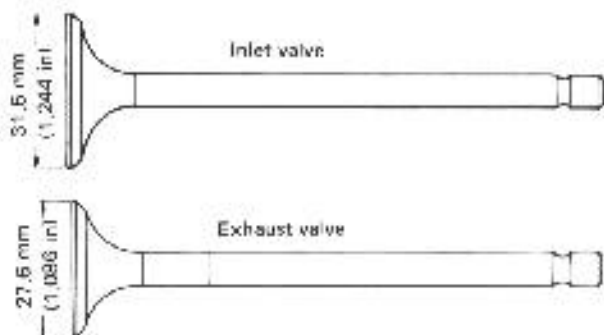

Fig. 3-120

Each valve spring has top end (large-pitch end) and bottom end (small-pitch end). Be sure to position the springs in place so that their bottom ends come on bottom side.



Fig. 3-121

To fit valve cotters to the groove provided on the end portion of each valve stem, be sure to use the valve lifter ① (09916-14510): compress the valve spring with this lifter and mount the cotter pieces, as shown in Fig. 3-122.

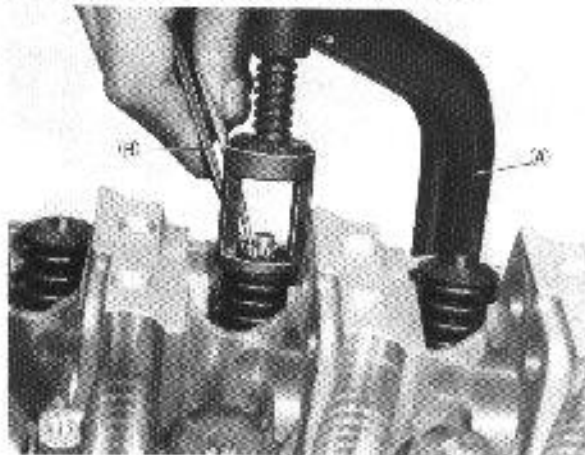

Fig. 3-122 (B) Forceps (09916-84510)

The positioning of cylinder head gasket on the cylinder block demands attention to this requirement: Tongue parts ① come on inlet manifold side, with hole ② falling in perfect register with hole ③. See Fig. 3-123. Be sure, too, that locating pins ④ are in place.

NOTE:

"TOP" mark ④, provided on the gasket, comes on top side; "IN" mark ⑤ comes on inlet manifold side and "EX" mark comes on exhaust side.

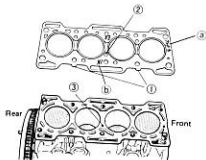

Fig. 3-123

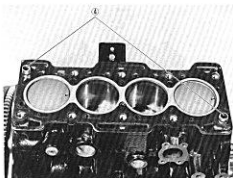

Fig. 3-124

The position the cylinder head takes on the block is but one, which is shown in Fig. 3-125. When placing the head on the block, be sure that it is correctly oriented: the clue is the inlet ports ⑤.

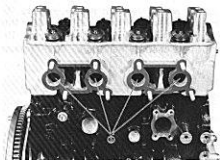

Fig. 3-125

The tightening sequence for cylinder head bolts is indicated in the photo. Tighten the bolts in that sequence to the specified torque value:

Tightening torque for cylinder head bolts	5.5 - 6.0 kg-m (40.0 - 43.0 lb-ft)
---	---------------------------------------

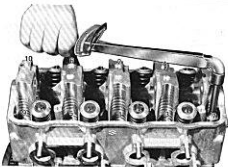

Fig. 3-126

Camshaft

The camshaft goes into cylinder head from front side. Before inserting it, be sure to oil its journals.

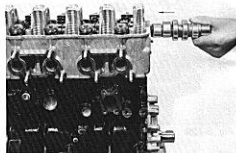

Fig. 3-127

Be careful not to leave out the thrust plate ① when installing the camshaft. After setting this shaft in place, with its thrust plate properly fitted, turn the shaft by hand to be sure it rotates smoothly.



Fig. 3-128

Rocker-arm shafts

CAUTION:

Turn the crankshaft to bring its keyway ② to the position indicated in Fig. 3-129, that is, making the keyway face sidewise, and then install the rocker-arm shaft. This crankshaft positioning is necessary because, if its keyway is in any other angular position, some valves will touch piston crowns, possibly resulting in damaged valves or piston crowns. Keep crankshaft in that angular position until the job of adjusting the timing belt tension is completed.

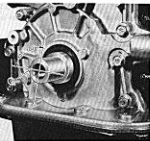

Fig. 3-129

The two rocker-arm shafts are identical, there being no need to distinguish between the two. However, each shaft takes but one position in place. See Fig. 3-130.

- On the inlet side, the stepped end ③ comes on front side.
- On the exhaust side, the stepped end ④ comes on rear side.

NOTE:

Oil rocker-arm shafts just before installing them.

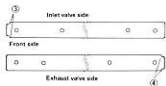

Fig. 3-130

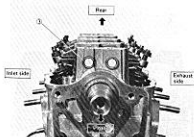

Fig. 3-131

As to the positions of rocker arms and springs on each rocker-arm shaft, refer to Fig. 3-132. "Front side" is meant by "1"; "rear side" by "2".

NOTE:

When installing rocker-arm shafts, be sure to have valve adjusting screws loosened fully but do not remove them.

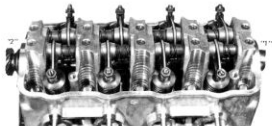

Fig. 3-132

Water inlet pipe

The angle that this pipe takes in place is important. When installing it, be sure to angle it as shown in Fig. 3-133.

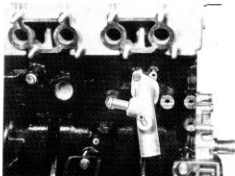

Fig. 3-133

Cylinder-head front side case

Two bolts ① for securing the front side case to cylinder head, Fig. 3-134, need SUZUKI BOND No. 4 (99000-31030), because the bolt holes for the two extend into the interior of cylinder head. Apply the SUZUKI BOND No. 4 to the threads of these screws before running them in.



Fig. 3-134

Crankshaft timing belt guide

This guide takes its position on crankshaft as shown in Fig. 3-135. Remember, one side of this guide faces the cylinder block and the other side faces the timing belt pulley; the former side being distinct from the latter.

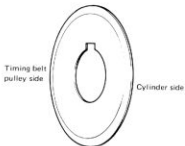

Fig. 3-135

Camshaft timing belt pulley

One side of this pulley has a punch mark ①—it is a point mark—as the reference for correctly positioning it on the camshaft. Fit the pulley to camshaft, bringing the punch-marked side to fan side and locating the mark ① at the keyway ② provided in camshaft.

CAUTION:

It is highly important that keyway ③ of crankshaft should face sidewise, as shown in Fig. 3-136. Check this first, and then install the timing belt pulley as above.



Fig. 3-136

Timing belt (valve timing adjustment)

A certain sequence must be followed in installing the timing belt. Here's the sequence:

- 1) Have the timing belt tensioner slackened so that it will move freely.

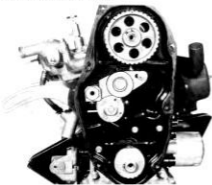

Fig. 3-137

- 2) Camshaft timing belt pulley has another punch-mark ④, which is located on the radial line passing through the punch-mark ① mentioned above. Now, timing belt inside cover has an embossed mark ⑤. Turn camshaft timing belt pulley to the position where mark ④ meets mark ⑤.

- 3) The inside cover has another embossed mark ⑥. Turn crankshaft to match keyway ③ of crankshaft timing belt pulley to mark ⑥.

CAUTION:

Never attempt to turn the crankshaft until mark ④ is indexed to mark ⑤.

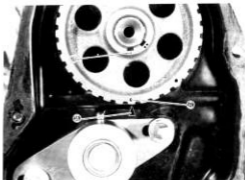

Fig. 3-138

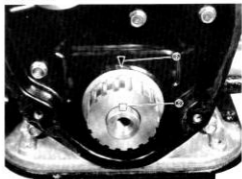

Fig. 3-139

- 4) You now have the two pulleys correctly related to each other in angular sense. Under this condition, put on the timing belt in such a way that portion of belt indicated as ⑦ is free of any slack.

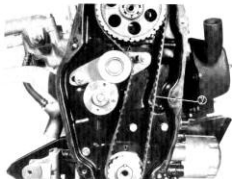

Fig. 3-140

- 5) After installing the belt, turn the crankshaft in clockwise direction until the camshaft starts rotating, thus making the portion (7) stiff and taut. Then, set the belt tensioner so that a proper tension will be produced in the belt. The proper tension is obtained this way: With the tensioner in freely movable condition, push it to apply a force of about 7.5 - 8.5 kg (16.5 - 18.7 lb) to the belt and lock the tensioner right there.
- 6) After retightening the bolt and nut, check to be sure that the tension is within specified range when pushing the belt at the mid point between camshaft and crankshaft.

Timing belt tension "C"	5.5 - 6.5 mm (0.22 - 0.26 in.)
-------------------------	-----------------------------------

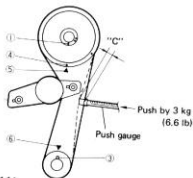

Fig. 3-141

- 7) After adjusting the belt tension within specified range, adjust each valve clearance to specified value.

CAUTION:

After setting the belt tensioner, turn crankshaft 2 rotations in clockwise direction to see if marks ① ④ ⑤ ⑥ and crankshaft keyway ③ locate themselves on the same straight line. If they do not line up straight, the foregoing procedure must be repeated to satisfy this requirement.

Valve clearance adjustment

The method of valve clearance adjustment is conventional. It is accomplished by means of adjusting screw (8). Nut (9) is for locking the screw. Use a feeler (thickness) gauge to measure the clearance between screw (8) and stem (10) when the rocker arm is turned up all the way.

Valve clearance specification (when cold)	Intake	0.13 - 0.18 mm (0.005 - 0.007 in.)
	Exhaust	

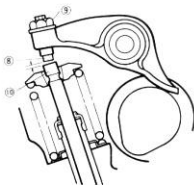

Fig. 3-142

Of the total of 8 valves, the question is how to bring the rocker arm to the position indicated in Fig. 3-143. There are two reference marks by which you can tell which valves are in the condition of Fig. 3-143. One is the key on camshaft, and the other is the "T" mark provided on flywheel.

Referring to Fig. 3-143, showing the end view of camshaft and pulley, turn crankshaft until the key comes to top position: at this position, check "valve clearance" on the inlet and exhaust valves of No. 4 cylinder. Rotate crankshaft further to relocate the key to the side position on the right; now the valves of No. 2 cylinder are ready for checking, and so on.

The method of positioning the valve mechanism by referring to the "T" mark on flywheel is similar; it will be set forth in the section for engine tune-up.

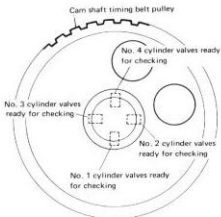

Fig. 3-143

Distributor gear case

Bolts ① are for securing this gear case to the cylinder block. When installing the case, be sure to apply SUZUKI BOND No. 4 (99000-31030) to the threads of these bolts.



Fig. 3-144

Distributor

The distributor takes its mounted position correctly only when it is inserted into the gear case under a specific condition. The condition is this: Turn over crankshaft to locate the piston at B.T.D.C. 10° (No.1 Piston being compression stroke), and insert the distributor into the case, with end face ② of distributor rotor lined up with embossed mark ③ of distributor housing, as shown in Fig. 3-145.

With the distributor correctly installed, as above, "ignition" must be timed to the specification. This timing is to be effected later at the time of making adjustments on the ignition system (Page 121).

CAUTION:

About 60 cc (2.03/2.11 US/Imp oz) of engine oil must be fed into the distributor gear case after servicing this case, that is, removing and putting it back. Be sure to add this much oil before starting the engine for the first time after servicing. For the filling point, remove the bolt on the case and use the bolt hole.

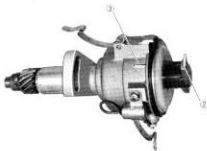

Fig. 3-145

Alternator

The water pump drive belt, by which the alternator too is driven, must be tensioned to the specification after the alternator is installed. Check the tension at the middle point of the belt between water pump pulley and alternator pulley. To vary the tension for adjustment, displace the alternator in place.

Drive belt tension (in terms of belt deflection as shown)	10 - 15 mm (0.4 - 0.6 in.) under 10 kg (22.0 lb) thumb pressure
---	--



Fig. 3-146

Clutch

At the time of bolting the clutch cover after mounting the clutch disc, the disc must be trued up and centered. Carry out this centering job with the use of the special tool (A) (09923-36310).



Fig. 3-147

3-7. Engine Inspection and Adjustments

Fan belt

Adjust the belt tension as outlined in the section for ENGINE COOLING SYSTEM (Page 107).

Distributor point gap

The method of adjusting the contact point gap is described in the section for IGNITION SYSTEM (Page 121).

Ignition timing

Refer to IGNITION TIMING, Page 121 .

Carburetor

Adjustments to be made are detailed in Page 93 .

Valve clearance

The method is described in 3-6. How to locate the respective rocker arms in clearance-checking position by turning the crankshaft in reference to the "T" mark provided on flywheel will be explained.

Valve clearance specification (COLD)	Intake	0.13 - 0.18 mm (0.005 - 0.007 in.)
	Exhaust	

Remove the plug—ignition timing check hole plug—provided at the joint between engine and transmission to gain visual access to the "T" mark. Turn over crankshaft to index mark ① to stationary mark ②, and see if the rocker arms of No. 1 cylinder are off the respective cam lobes (of camshaft); if so, valves ①, ②, ⑤ and ⑦, Fig. 3-149, are ready for clearance checking and adjustment: if not, turn over crankshaft further by 360° to index mark ① to mark ② again. This 360° turning should bring about the desired state (in which the four valves are ready for checking and adjustment).

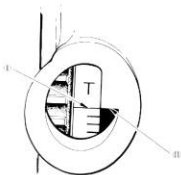

Fig. 3-148



Fig. 3-149

After checking valves ①, ②, ⑤ and ⑦, turn over crankshaft by 360° to make valves ③, ④, ⑥ and ⑧ ready for checking and adjustment.

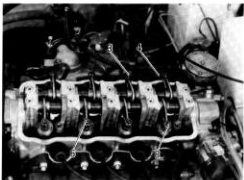

Fig. 3-150



Fig. 3-151 Measuring valve clearance



Fig. 3-152 Adjusting valve clearance

Timing belt

Periodical inspection is required of this belt. Inspect it for cracks, cleanliness, oil stains and signs of breakage and replace the belt, as necessary. To inspect the belt, the radiator shroud panel must be raised. Here's the method:

- 1) Undo the two clamped connections of the warm air hose, and remove the hose.
- 2) Remove the 6 bolts securing the radiator shroud panel.
- 3) Raise the panel to keep it out of the way, and look into the belt check hole to observe the belt.



Fig. 3-153

Too much slack of timing belt gives camshaft revolution unsteady which affects distributor noise.

Inspect the belt slack also from timing belt inspection window by following step.

Turn the crankshaft counter-clockwise to give tension on the belt to the tensioner side (left), and push the belt with fingertip to see how much it deflects. If it deflects more than 15 mm (0.6 in) adjust the belt. Refer to timing belt slack adjustment (page 81).

Oil pump discharge pressure measurement

The method of pressure measurement is outlined in the section for ENGINE LUBRICATION (Page 91).

Compression pressure measurement

Check the compression pressure on all four cylinders, as follows:

- 1) Remove all spark plugs.
- 2) Install the compression gauge (A) (09915-64510) on one of the cylinders, making the connection perfectly air-tight.
- 3) Disengage the clutch (to lighten starting load on engine), and depress the accelerator all the way to make the throttle full-open.
- 4) Crank the engine with the starter motor, and read the highest pressure on the compression gauge.
- 5) Carry out the steps 2) through 4) on each cylinder to obtain four readings.

Compression pressure

Standard	Limit	Difference
13.5 kg/cm ² (192.0 psi)/ 300 r/min (rpm)	12.0 kg/cm ² (170.0 psi)/ 300 r/min (rpm)	1.0 kg/cm ² (14.2 psi)/ 300 r/min (rpm) between any two cylinders

NOTE:

There is some trouble in the engine when the compression pressure is not higher than the limit. Refer to TROUBLE-SHOOTING GUIDE (Page 25) for possible causes.



Fig. 3-154

Vacuum measurement

The vacuum that develops in the intake line is a good indicator of the condition of the engine. It is for this reason that the vacuum is measured. The measuring procedure is as follows:

- 1) Run the engine until its coolant temperature rises to a level between 75°C and 85°C (167°F - 185°F).
- 2) Install the vacuum gauge (A) (09915-67310), as shown in Fig. 3-155. Install an engine tachometer.
- 3) Run the engine at the specified idling speed and, under this running condition, read the vacuum gauge. The vacuum should be not lower than 40 cm Hg (15.7 in. Hg).

A low vacuum reading means that any combination of the following malconditions is the cause, which must be corrected before releasing the machine to the customer:

- (a) Leaky cylinder head gasket
- (b) Leaky inlet manifold gasket
- (c) Leaky valves
- (d) Weakened valve springs
- (e) Maladjusted valve clearance
- (f) Valve timing out of adjustment
- (g) Ignition mistimed
- (h) Carburetor improperly adjusted

NOTE:

Should the indicating hand of the vacuum gauge oscillate violently, turn the adjusting nut (B) to steady it.

Standard vacuum	40 ~ 50 cm Hg (15.7 ~ 19.7 in. Hg)
Idling speed specification	850 rpm (Take vacuum reading at this speed.)



Fig. 3-155

Engine oil

Refer to the section for ENGINE LUBRICATION, Page 92.

Engine oil filter

The methods of checking and servicing the oil filter are outlined under ENGINE LUBRICATION, Page 91.

Engine coolant

This subject is covered in the section for ENGINE COOLING SYSTEM, Page 107.

Exhaust line and muffler

Inspect each exhaust line connection for tightness, and examine the muffler and other parts for evidence of breakage and leakage of gases. Repair or replace defective parts, if any.



Fig. 3-156

Crankcase ventilation hose

Inspect this hose for cracks and evidence of breakage and, as necessary, replace it. Check to be sure that the hose connection is tight.



Fig. 3-157

Oil filler cap

The cap has a packing. Be sure that the packing is in good condition, free of any damage and signs of deterioration, and is tight in place: it is replaceable.



Fig. 3-158

3-8. Engine Lubrication

Description

The oil pump for pressure-feeding lubrication oil to the running parts of the engine is of an internal gear type, in which an outer ring-like gear is internally meshed with an inner gear, there being a separating crescent-like stator between the two. The pump is mounted on the front end of the engine, and is driven by the crankshaft.

OIL CIRCUIT: The oil pump lifts oil through the strainer and discharges it under pressure, forcing the oil through the oil filter. The filtered oil flows into two paths inside the cylinder block. In one path, oil reaches the crankshaft journal bearings and big-end bearings on crankpins. Some of this oil goes to the connecting-rod small ends and lubricates piston pins there and also the walls of cylinder bores. In the other path, oil goes up to the cylinder head through the camshaft center journal and enters the internal oilways of rocker arm shafts to lubricate the sliding parts of these shafts and also the five journals of the camshaft.

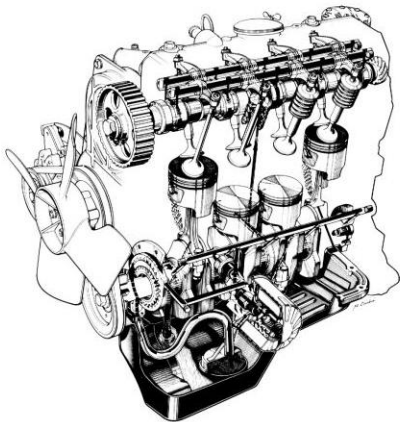

Fig. 3-159

An oil relief valve is provided on the oil pump. This valve starts relieving oil pressure when the pressure comes over about 4.5 kg/cm^2 (64.0 psi). Relieved oil flows back to the oil pan.

Oil pump disassembly

Remove oil pump gear plate.



Fig. 3-160

Take out inner gear.



Fig. 3-161

Take out outer gear.



Fig. 3-162

Oil pump inspection

Radial clearance between inner gear and crescent

Standard	0.60 - 0.80 mm (0.0236 - 0.0315 in.)
----------	---



Fig. 3-163

Radial clearance between outer gear and crescent

Standard	0.25 - 0.40 mm (0.0098 - 0.0157 in.)
----------	---

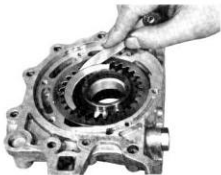

Fig. 3-164

Radial clearance between outer gear and pump case case

Limit	0.3 mm (0.0118 in.)
-------	---------------------

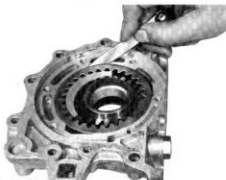

Fig. 3-165

Side clearance:

Using a straightedge, determine the side clearance in terms of the thickness gauge reading taken between straight edge and gear, as shown in Fig. 3-166.

Limit on side clearance	0.17 mm (0.0067 in.)
-------------------------	----------------------



Fig. 3-166

Oil pump reassembly

Have all disassembled parts washed clean, and rebuild the pump to meet each of the following requirements:

- Outer gear has a punch mark ①. Fit outer gear into the pump case, with this punch-marked side coming on plate side.



Fig. 3-167

- Use a new gasket when fitting the oil pump case to the cylinder block. The edge of the gasket might bulge out; if it does, cut the bulge off with a sharp knife, making the edge smooth and flush with the end face of the pump case, and apply SUZUKI BOND No. 4 to the cut edge.

NOTE:

Before fitting the pump case, oil the oil seal lip.

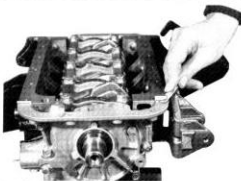

Fig. 3-168

- Installation of crankshaft timing belt pulley and timing belt must be carried out in strict conformity to the special instructions given in Page 80 for engine reassembly.

CAUTION:

Strict adherence to the special instructions is essential, for an improperly installed pulley and timing belt prevents the engine from operating as designed.

Oil filter servicing

At intervals stated below, replace the oil filter element. The element must be replaced not only periodically but also whenever it is found dirty.

Initial replacement to be made:	After 1,000 km (1,000 miles)
Replace at intervals of:	Every 10,000 km (6,000 miles)

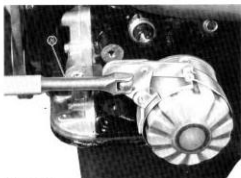

Fig. 3-169 Oil filter wrench (K) (09915-47310)

Oil pump strainer servicing

- Inspect the strainer periodically and, as necessary, clean it by washing to remove dirty matters clogging its screen.
- When securing the strainer, be sure to tighten up two bolts on pump side before tightening the others.

Checking the oil pressure

When the engine is idling, not to mention fast running, the oil pressure light should remain completely off; if not, it is a cause for checking the oil pressure in the following manner:

- 1) Be sure that engine oil is up to level in the oil pan. Refill the oil pan, as necessary, to raise the oil to and above "LOW" line on the level gauge. Be sure, too, that the oil filter is clean and that the oil pump strainer is not clogged. Check to be sure that there is no oil leakage from any part of the engine.
- 2) Remove the oil pressure unit, which is mounted on that side of the cylinder block where the oil filter is located. Into the vacated threaded hole, screw the pressure gauge connection to install the gauge (B) (09915-77310).



Fig. 3-170

- 3) Start up the engine and idle it until the coolant temperature rises to a level between 75° and 85°C (167° - 185°F). At this temperature, raise engine speed to 3,000 rpm and read the pressure gauge indication.

Oil pressure specification	3.0 - 4.5 kg/cm ² (42.66 - 63.99 psi) At 3,000 rpm
----------------------------	---

If the pressure read is not up to the specification, the oil pump must be checked.

CAUTION:

When re-installing the oil pressure unit, be sure to wrap its screw threads with a sealing tape. Tighten the unit to a torque value of 1.2 to 1.5 kg-m (9.0 - 10.5 lb-ft).

Engine oil servicing

For the engine oil, use a 4-stroke engine oil (Refer to page 22). Each oil change requires this much oil:

Periodical oil change	3,000 cc (6.34/5.28 US/Imp pt)
Filling up after engine overhauling	3,500 cc (7.39/6.16 US/Imp pt)

Oil level:

Refill the engine oil whenever necessary, in order to maintain the oil surface between "LOW" and "FULL" lines on the oil level gauge.

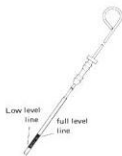

Fig. 3-171 Oil level gauge

4. CARBURETOR

4-1. Description	94
4-2. Carburetor Specifications	94
4-3. Carburetor Operation	96
4-4. Inspecting and Adjusting	97

4-1. Description

The carburetor, serving all four cylinders, is of a horizontal-draft Solex type, composed of the following component parts:

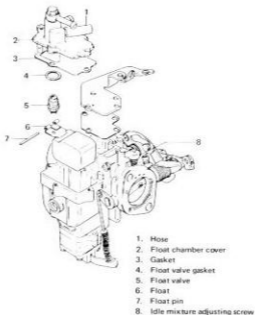

Fig. 4-1

4-2. Carburetor Specifications

Item	Specification
Venturi diameter	24 mm (0.945 in.)
Main jet	≅ 105
Main air hole	0.5
Slow jet	≅ 57.5
Slow air jet	1.6

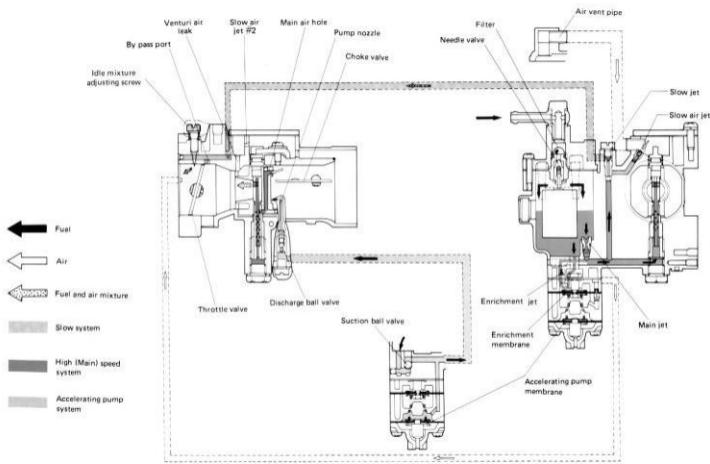

Fig. 4-2 Carburetor circuit diagram

4-3. Carburetor Operation

Float chamber

The float chamber with its needle valve is a vessel receiving the fuel from the fuel pump and holding it up to a certain constant level. The float responds to the up-and-down movement of fuel surface and actuates the needle valve.

Slow speed mixture

Referring to Fig. 4-2, fuel flows out of the float chamber through main jet and reaches slow jet. Slow air jet admits air, metering this air and sends it to the inlet side of slow jet, which meters this mixture of fuel and air into the slow circuit terminating at idle port and bypass port. These two ports open out to the main bore, near throttle valve.

During idling, the slow speed mixture (coming from slow jet) is sprayed out mainly from idle port and becomes mixed with the air flowing into the main bore. Thus, the air-fuel mixture can be made richer or leaner by re-setting idle mixture adjusting screw in loosening or tightening direction, respectively, in that order.

High speed mixture

Two circuits come into operation for producing the high speed mixture. One circuit begins with main jet, which meters out fuel from the float chamber. This fuel is mixed with the air meteringly admitted by main air hole; this mixing is effected in emulsion tube. The emulsified mixture is then sprayed out into the venturi from main bleed pipe.

The other circuit goes into service when the manifold vacuum falls to move the diaphragm in the enrichment device below the float chamber. As the diaphragm so moves, the valve above it opens to let out fuel through the hole provided in the chamber bottom. Enrichment jet meters out this fuel and sends it to emulsion tube, from which it flows into main bleed pipe and is sprayed into the venturi.

Acceleration power system

The main device of this system is an accelerating pump for making the carburetor respond without delay to the accelerator pedal depressed abruptly while the engine is running in its low speed range or is idling.

The actuating lever of this pump is linked to the throttle shaft so that, as throttle valve opens quickly, the pump lever pushes up the diaphragm, thereby closing suction ball valve and opening discharge ball valve. Consequently, the fuel in the pump is forced out of pump nozzle into the venturi.

4-4. Inspecting and Adjusting

Jets

Wash the jets clean. Wash the holes in which jets are located, and clear each hole by directing compressed air to it, thereby removing foreign matter, if any.

A clogged slow jet is usually responsible for erratic engine idling. Erratic engine operation in the medium and high-speed ranges and during acceleration is often accounted for by a clogged condition of main jet, main air hole or hole constrictions in the carburetor body.



Fig. 4-3

Needle valve

The conical tip of needle valve is subject to wear as this tip seats and unseats in the normal operation of the needle valve. When the needle valve is in closed condition, this tip is pushed against the seat by the float.

Inspect the conical tip and seat for evidence of clogging. As necessary, remove the seat and wash it clean. A worn needle, illustrated in Fig. 4-4, must be replaced. Remember, a clogged or poorly seating needle valve is usually accountable for "overflow."

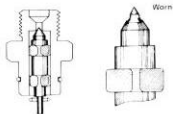

Fig. 4-4

Choke valve

Check to be sure that, when the choke knob is pulled out all the way, the shaft of choke valve in the carburetor will rotate, and that, when the knob is pushed in, the shaft will rotate back to original position.

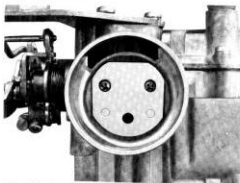

Fig. 4-5 Choke valve (with knob pulled out fully)



Fig. 4-6 Choke valve (with knob pushed in fully)

Accelerator and choke cables

Inspect these cables for wear and tear, and check to be sure that each cable connection is in sound condition. Do not hesitate to replace a defective cable or other part; when installing a replacement cable, tighten the connections good and hard.



Fig. 4-7

Fuel hose

Inspect the hose for cracks and signs of breakage, and replace it as necessary. Examine it for signs of leakage, too. Be sure that the hose is free of any leak and that its connections are tight.

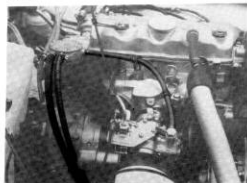

Fig. 4-8

Fuel tank cap

This cap is fitted with a rubber packing. Be sure that the packing is in good condition and that the cap in place is tight and leak-free.



Fig. 4-9

Fuel level adjustment

To see if the fuel is maintained at normal level in the float chamber, or not park the machine on a level floor and look into the glassed inspection window. If the fuel surface is visible at the middle of the window, the needle valve is working properly.



Fig. 4-10

Fuel level adjustment must be made if the surface is too high or too low as seen in the inspection window. The method of adjustment is as follows: 1) Remove float chamber cover, and bend the tongue ①, Fig. 4-11, upward (to lower the level) or downward (to raise the level). Tongue ① is the part in contact with needle valve.



Fig. 4-11

Idle speed and idle mixture adjustment

NOTE:

Requires external tachometer.

1) As preliminary steps, check to be sure that:

- Coolant temperature is approximately 80°C (176°F).

75°~105°C (167°~221°F)

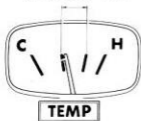

Fig. 4-12

- Choke valve is in the full-open position.
- All accessories (wipers, heater, lights, etc.) are out of service.
- The ignition timing is within specification.
- Fuel level in the carburetor fuel reservoir should be at the center of the window, as shown in Fig. 4-10 when the engine is running at $2,000 \pm 50$ r/min (rpm).
- The air cleaner has been properly installed and is in good condition.

[Idle speed and idle mixture adjustment]
Adjust idle speed by repositioning the idle speed adjusting screw (2), making sure the engine idles steady at 850 ± 50 r/min (rpm).

Idle mixture adjusting screw (3) generally needs no adjustment. However, when the adjusting screw is removed to overhaul the carburetor, adjustment is necessary as follows:

Tighten idle mixture adjusting screw (3) fully position where the engine speed is the highest (best idle). Then, readjust the engine idling speeds to 850 r/min (rpm) with idle speed adjusting screw (2).

CAUTION:

- When cars are used in countries where exhaust gas regulations are in force, check the exhaust gas with an exhaust gas tester. If gas exceeds the value specified in the regulations, adjust the idle mixture adjusting screw (3).

Engine idling speed specification	850 ± 50 r/min (rpm)
-----------------------------------	--------------------------



Fig. 4-13 (4) Tightening torque: 1.8 kg·m (13.0 lb-ft)

5. AIR CLEANER, FUEL PUMP AND FUEL FILTER

5-1. Air Cleaner	102
5-2. Fuel Pump.....	104
5-3. Fuel Filter.....	105

5-1. Air Cleaner

Description

Air cleaner is dry type consisting of outer and inner cleaner elements.

These cleaner elements can be used repeatedly by performing the following cleaning work.



Fig. 5-1

Air cleaner element inspection and servicing

1) Take out the cleaner elements off the air cleaner case.



Fig. 5-2

2) Separate outer cleaner element from inner cleaner element.

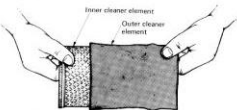

Fig. 5-3

3) Blow off dust on inner and outer cleaner elements by compressed air.

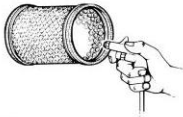

Fig. 5-4

NOTES:

- If the elements are heavily dirtied wash them in non-flammable cleaning solvent, and dry with compressed air.

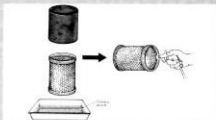

Fig. 5-5

- A fissured, torn or otherwise defective element must be replaced.
- Never twist and wring the element or it will develop fissures.

Air cleaner element cleaning interval	Every 2,500 km (1,500 miles)
--	---------------------------------

Use of the selector lever

A mispositioned selector lever can cause the carburetor to get "iced" in freezing weather or the engine to overheat in hot weather. Position this lever according to the atmospheric temperature, i.e., in WINTER position when outside temperature is 15° C (59° F) or below, or in SUMMER position when the temperature is above that level.

Warm-air selector lever position	
Atmospheric temperature	Lever position
15° C (59° F) or below	WINTER
Above 15° C (59° F)	SUMMER



Fig. 5-6 ① Warm air selector lever

5-2. Fuel Pump

Description

A pneumatic diaphragm pump is used to deliver gasoline to the float chamber in the carburetor. Its diaphragm is actuated from one of the cams formed of engine camshaft. A rocker arm rides on this cam and moves the pump diaphragm up and down. A fuel return circuit is provided in this pump in order to avoid "vapor lock." When the float chamber refuses to admit fuel, a slight pressure buildup occurs on the discharge side of the pump and this buildup causes the fuel to flow through the return circuit to the fuel tank. In other words, the fuel pump is kept in action as long as the engine is running, so that the constant flow of fuel through the pump keeps it cooled.

Fuel pump specifications	
Discharge pressure	0.25 - 0.35 kg/cm ² (3.55 - 4.97 psi)
Pump capacity	1.3 litres/minute or better at 2,000 rpm

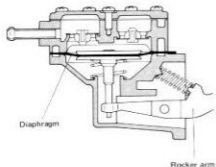

Fig. 5-7

Important pump disassembling step

Scribe match marks (1) across the joint seams to establish and identify the angular positions of upper half (2) and lower half (3), as shown in Fig. 5-8. This provision is necessary because the screw holes are so located as to permit the two halves to be angularly positioned in more than one way, whereas the pump can be piped only when the pump is assembled as shown.

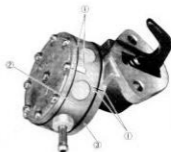

Fig. 5-8

Inspection

- Inspect the fuel pump in place for leakage.
- Be sure that the fuel hose is free of any sign of cracking.
- Be sure that the nuts securing the pump in place are tight.
- After disassembling the pump, examine the diaphragm to be sure it is in good condition, free of any evidence of rupture or breakage.



Fig. 5-9

Important pump reassembling

Be sure to fit the upper half and lower half as guided by the match marks ① given at the time of disassembly. With two halves ② ③ correctly positioned, run in the screws and tighten them equally.

CAUTION:

Tighten the screws while depressing the rocker arm of the fuel pump (i.e. the rocker arm return spring is depressed).

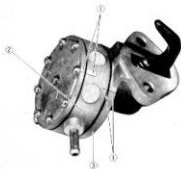

Fig. 5-10

5-3. Fuel Filter

Description

Fuel enters the filter through its inlet hole and, after passing through the filtering element, comes out of its outlet hole communicated to the fuel pump. This filter is not meant to be disassembled. It is of cartridge type, consisting of a filtering element in a plastic case.

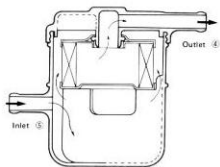

Fig. 5-11

Servicing and installation

As said before, this filter does not permit disassembly: it is to be replaced by a new one periodically. It is one of the expendable items.

Interval of fuel filter replacement	Every 40,000 km (25,000 miles)
-------------------------------------	--------------------------------

CAUTION:

Fig. 5-11, above, shows the fuel filter in its correct posture, with outlet ④ coming on top side and inlet ⑤ on bottom side. Remember the relative positions of inlet and outlet when piping the filter.

6. ENGINE COOLING SYSTEM

6-1. Description	108
6-2. Cooling Water Circuit	108
6-3. Removal	109
6-4. Functional Description of Major Components.	110
6-5. Cooling System Services	114
6-6. Important Re-installing Steps	116

6-1. Description

The engine is cooled by coolant set in forced recirculation through jackets formed in the engine body and through the radiator. For the water pump, a high-capacity centrifugal pump is used. For the radiator, a tube-and-fin type, large in heat dissipating capacity, is used.

The thermostat is of wax pellet type, accurately responsive to temperature changes and durable in construction. It maintains the coolant temperature within a narrow range during operation.

6-2. Cooling Water Circuit

The thermostat remains in closed condition—its valve is closed—when the coolant is cold. Under this condition, the coolant being pumped flows through the circuit comprising cylinder block, cylinder head, inlet manifold, bypass hose and water pump, in that order.

As the temperature rises to 82°C (179°F) or thereabout, the thermostat begins to open, thereby allowing some of the coolant in recirculation to flow through the radiator. At about 95°C (203°F) of rising coolant temperature, the thermostat becomes completely open so that little or no flow occurs through the bypass hose: the coolant now flows through the radiator and back to the pump, releasing the most of heat to the atmosphere through the radiator core.

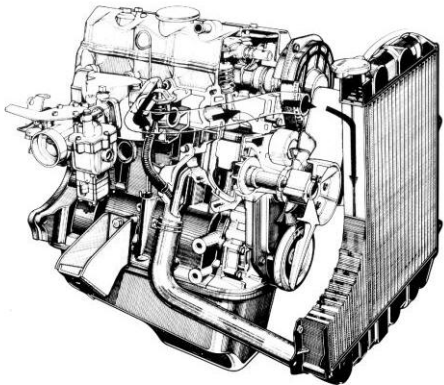

Fig. 6-1

6-3. Removal

1. Coolant draining

- 1) Loosen the drain plug (1) on the radiator to empty its water side.

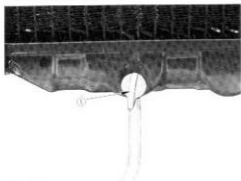

Fig. 6-2

- 2) The drain plug (2) for engine water jackets is located below the exhaust manifold. To change the coolant, or to drain the jackets for one reason or another, loosen this plug, too.



Fig. 6-3

2. Removal of cooling water pipes

To remove these pipes, loosen the screw on each pipe clip and pull the pipe end off. In the machines equipped with the heater, leave the heater valve in open (slackened) position.



Fig. 6-4

3. Radiator removal

Remove the lower shroud panel, and loosen the bolts securing the radiator in place. Take out the radiator by lifting; it comes out complete with its upper shroud panel.



Fig. 6-5

4. Cooling fan removal

Removing the bolts securing the fan to the hub allows the fan to be detached.



Fig. 6-6

5. Water pump removal

In order to remove the water pump, it is not necessary to take down the engine. The method of removal is sequentially illustrated in Figs. 3-12, 3-13, 3-15, 3-16, 3-17, 3-18, 3-19, 3-20, 3-21 and 3-23.

In these figures, cautioning reminders are given. Be sure to pay attention to those reminders when removing the pump.

The method of re-installing the pump is sequentially illustrated in Figs. 3-136, 3-137, 3-138, 3-139, 3-140, 3-141, and 3-142.

6-4. Functional Description of Major Components

Water reservoir tank

This reservoir, a small tank, is so located relative to, and so associated with the radiator that it receives the excess coolant that would otherwise spill out by overflowing. The excess is due to coolant expansion caused by temperature rise. When the coolant cools down, its volume contracts, and the coolant in the reservoir returns to the radiator.



Fig. 6-7

Thermostat

The temperature-sensitive material in the thermostat is a wax pellet. It is hermetically contained in a metal case, and expands and contracts according as the coolant temperature rises and falls. When it expands, the case pushes down the valve to open it.

If, during operation, the valve is suspected of remaining closed while it is expected to open increasingly, the cause is most likely a ruptured wax case.

In the top portion of the thermostat, an air bleed hole is provided; this hole is for venting out the gas or air, if any, that has accumulated in the coolant circuit.

Thermostat functional specifications	
Temperature at which valve begins to open	82° C (179° F)
Temperature at which valve becomes full open	95° C (203° F)
Valve lift	8 mm (0.31 in.)

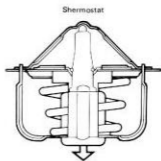

Fig. 6-8

Radiator filler cap

This cap has two built-in valves and, by these valves, allows the internal pressure of coolant circuit to rise to a certain level slightly above that of the atmosphere.

Of the two built-in valves, one is an adjusting valve and the other is a negative-pressure valve. The former opens only when the internal pressure rises by 0.9 kg/cm². This means that the coolant's boiling temperature is substantially above 100°C (212°F)—if the coolant

is straight water—and that, under normal running condition, no boiling occurs to reduce the coolant's heat capacity.

Following a shutting down of the engine, the coolant will cool off and the internal pressure will drop. If the pressure should be allowed to keep on falling, there happens the danger of coolant pipes and radiator cores becoming subjected to a large collapsing pressure: the pipes or radiator cores or any weakest point might give in. The negative-pressure valve opens in such a case to admit atmospheric pressure into the coolant circuit, thereby avoiding a build-up of negative pressure.

The cap has its face marked "0.9, which means that its pressure adjusting valve opens at 0.9 kg/cm².



Fig. 6-11

Requirements on coolant

The long-term reliability and cooling capacity of the engine cooling system depends much on the quality of cooling water used. "Hard water," if used, will foul up the cooling circuit by scale formation, for such water is usually high in silicate and mineral contents. Scales are poor heat conductors.

Use of water high in acid concentration is just as bad; such water promotes rusting. For similar reasons, river water, well water, not to mention sea water, are not fit as engine cooling water.

Tap water available from city water supply is the best available water, in a practical sense, for the cooling system. Distilled water is ideal but is a luxury in most cases.

For protection of the cooling circuit, it is recommended that GOLDEN CRUISER 1200 (which is included as a regular item in the supply of materials from SUZUKI) be added to the cooling water in a proportion determined by the lowest atmospheric temperature expected.

Each LJ80 (and LJ80V) machine is shipped from the factory with its cooling circuit filled with a 50% solution of GOLDEN CRUISER 1200; this solution does not freeze down to -36°C (-33°F).

Many brands of ANTI-FREEZE compounds are sold in the market. In no case, allow two or more different brands to be mixed in the cooling circuit of the engine.

Radiator cap



Operating pressure adjusting valve

Fig. 6-9

Radiator cap



Operating vacuum valve

Fig. 6-10

Water pump

The pump rotor is supported by a totally sealed bearing. The seals are of high-durability type and do not permit disassembly. For this reason, the pump must be replaced by a new one when any part of it has developed a malfunction of a kind that can be corrected in an ordinary water pump by disassembly and servicing.

GOLDEN CRUISER 1200 "Anti-freeze and Summer Coolant"—its effects and use

- (1) Effects of GOLDEN CRUISER 1200 coolant
- (a) Its freezing temperature is much lower and depends on the concentration of GOLDEN CRUISER 1200. It is an anti-freeze coolant.
 - (b) It does not corrode the metal surfaces of the cooling circuit. It is an anti-corrosion coolant.
 - (c) It does not develop foam or bubbles. It is a foam-inhibited coolant.
 - (d) It stands long usage. The renewal intervals is much longer.



Fig. 6-12

(2) How to proportion GOLDEN CRUISER 1200 to cooling water

GOLDEN CRUISER 1200 is a multi-purpose anti-freeze compound. Its aqueous solution as engine coolant can be kept in service as long as two years in a single stretch, regardless of changes of season.

To prepare an anti-freeze coolant with GOLDEN CRUISER 1200, proportion this compound to water according to the following chart, in which the proportions are indicated for seven levels of temperature as the lowest expected levels:

ANTI-FREEZE PROPORTIONING CHART

Freezing temperature	°C	-9	-12	-16	-20	-25	-30	-36
	°F	16	10	3	-4	-13	-22	-33
GOLDEN CRUISER concentration	%	20	25	30	35	40	45	50
Ratio of compound to cooling water	ltr.	0.76/ 3.04	0.95/ 2.85	1.14/ 2.66	1.33/ 2.47	1.52/ 2.28	1.71/ 2.09	1.90/ 1.90
	US pt.	1.60/ 6.42	2.00/ 6.02	2.40/ 5.62	2.81/ 5.21	3.21/ 4.81	3.61/ 4.41	4.01/ 4.01
	Imp.pt.	1.33/ 5.35	1.67/ 5.01	2.00/ 4.68	2.34/ 4.34	2.67/ 4.01	3.01/ 3.67	3.34/ 3.34

NOTE:
Remember, the radiator capacity is 3.8 litres (8.02/6.68 US/Imp.pt.) which includes the reservoir tank capacity of 0.6 litre (1.27/1.07 US/Imp.pt.).

Water temperature gauge

This gauge constitutes a system of its own, with an indicator mounted in the instrument panel, an engine unit or sensor of thermistor type and a regulator for passing a constant current. These three—engine unit, indicator and regulator—are connected as shown in the diagram below:

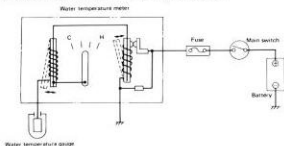

Fig. 6-13

The indicator is of bimetal type; its bimetal element is wrapped with a heater coil and becomes heated by the current flowing in the coil. By deflecting, the element actuates the indicating hand, making the hand move along the temperature scale.

The magnitude of the current is determined by the state of the thermistor in the engine unit. This unit is installed on the intake manifold. Speaking generally, a thermistor is a semiconductor resistive element whose ohmic resistance decreases as its temperature rises; its resistance has a negative temperature coefficient. When the coolant temperature rises, the thermistor offers a decreasing resistance, so that the current increases, thereby deflecting the indicating hand wider.

The regulator is a means of maintaining a constant current in the circuit for each ohmic resistance state of the thermistor, and does so function under the varying voltage condition of the battery.

6-5. Cooling System Services

Thermostat

If the thermostat valve is suspected of malfunctioning, check first the possibility of some foreign matters being stuck on the valve seat to prevent the valve from seating tight. Next, check the thermostatic movement of the wax element in the following manner:

Heat water in a pan by placing the pan on a stove, as shown in Fig. 6-14. Grip the end of a thread or small string by pinching it in the valve and suspend the thermostat unit by holding the other end of the thread or string. Immerse it in the water, holding it about 20 mm (0.78 in.) above the bottom, and read the water temperature on the column thermometer.

If the suspended unit falls to the bottom (by releasing the gripped end of the thread or string) just when the temperature rises to 82°C (179°F) or thereabout (which is the temperature at which the valve should begin to open), the thermostat unit may be deemed to be in sound condition.

If the valve begins to open at a temperature substantially below or above, the thermostat unit should be replaced by a new one. Such a unit, if re-used, will bring about overcooling or overheating tendency.



Fig. 6-14

Make sure that the air bleed hole of the thermostat is clear. Should this hole be clogged, the engine would tend to overheat.



Fig. 6-15

Fan belt

This belt drives both cooling fan and water pump. Check the belt for tension. The belt is in proper tension when a thumb pressure applied to the middle point of its span deflects it about 10 - 15 mm (0.4 - 0.6 in.). Inspect the belt for signs of deterioration and replace it as necessary.

Belt tension specification	10 - 15 mm (0.4 - 0.6 in.) as deflection
----------------------------	--

NOTE:

When replacing the belt with a new one, adjust belt tension to 8 - 10 mm (0.3 - 0.4 in.).



Fig. 6-16

To adjust the belt for proper tension, loosen the 3 bolts securing the generator in place, and displace it to slacken or tighten the belt.

A loose belt, or a belt tending to break off or otherwise defective, is often the cause of engine overheating. Because of the importance of this belt, it is strongly recommended that the belt be replaced at regular intervals even when the belt looks satisfactory in appearance.

Belt replacement interval	Two years (recommended)
---------------------------	-------------------------

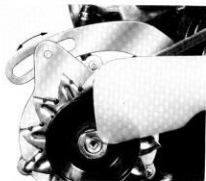

Fig. 6-17

Radiator

If the water side of the radiator is found excessively rusted or covered with scales, clean it by flushing with the radiator cleaner compound. This flushing should be carried out at regular intervals for scale or rust formation advances with time even where a recommended type of coolant is used. Periodical flushing will prove more economical.

Inspect the radiator cores and straighten the flattened or bent fins, if any. Clean the cores, removing road grimes and trashes.

Excessive rust or scale formation on the wet side of the radiator lowers the cooling efficiency. Flattened or bent fins obstruct the flow of air through the core to impede heat dissipation.

Radiator flushing interval	Two years (recommended)
----------------------------	-------------------------

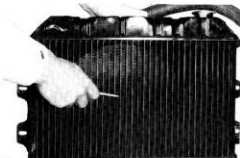

Fig. 6-18

Coolant level

Cooling water in service decreases its volume gradually on account of progressive loss due to water evaporation. Check to be sure that the water surface is up to anywhere between FULL and LOW marks on the reservoir tank. The user should be reminded of the need to daily check the water level.



Fig. 6-19

Water hoses

Inspect each water hose for evidence of cracking or breakage, and be sure that its connection is tight. A defective hose or a hose showing signs of malcondition must be replaced. Tighten the hose connections as necessary.



Fig. 6-20

6-6. Important Re-installing Steps

Thermostat

When positioning the thermostat on the inlet manifold, be sure to bring its air breather hole (1) to front side of the engine.



Fig. 6-21

Filling up the cooling system

Park the machine on a flat level floor, and fill in until you see the coolant come up to the well part of the radiator filler. Then, run the engine two or three minutes to recirculate the coolant. This recirculation will drive out air, if any, trapped inside, and will lower the coolant surface at the filler. Add coolant until its surface shows up again in the filler, and fill up the reservoir tank, raising the surface to FULL mark.



Fig. 6-22

7. CAR HEATER

7-1. Description	118
7-2. Electrical Circuit	118
7-3. Heater Services	119

7-1. Description

The optional car heater is of hot water type. Its operation is quiet. It takes engine heat through the medium of water and sends warm air into the room by means of a blower.

Since the blower drive is electrical, independent of engine speed, the heater is just as effective even when the engine is running slowly. In summer, the blower doubles as a fan for room ventilation, with the heater valve kept closed.

7-2. Electrical Circuit

The circuit diagram shown in Fig. 7-2 illustrates how the blower motor is controlled. With the main switch closed, pulling the button of the three-position fan switch to the first position passes a current through the motor. This current is small because the circuit has a resistor (indicated as "fan resistance" in the diagram); and the blower runs slow under this condition.

Pulling the switch button all the way (to the second position) throws the full battery voltage across the blower motor. A large current flows, and the blower runs with full speed.

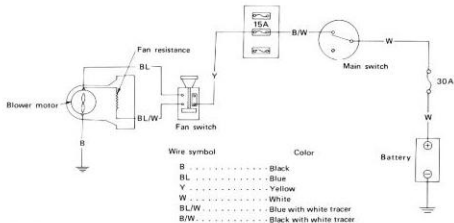

Fig. 7-1

7-3. Heater Services

Fan resistor

This resistor is in the heater case. Inspect it for signs of cracking or breakage and replace it if necessary. If the blower motor will not run or when you replace the existing resistor, check to be sure the resistor has an ohmic resistance of 4.3 ohms. Use a circuit tester for this purpose.

Fan resistor specification	4.3 ohms
----------------------------	----------



Fig. 7-2

Fan switch

Using a circuit tester, check this switch for circuit continuity:

- (1) Switch button in first position
Continuity should be verified between YELLOW and BLUE/WHITE.
- (2) Switch button in second position
Continuity should be verified between YELLOW and BLUE.



Fig. 7-3

Wire Color Switch Position	Yellow	Blue/White	Blue
OFF			
First position (1)	○	○	
Second position (2)	○		○

Heater fan switch

8. IGNITION SYSTEM

8-1. Description	122
8-2. Description of Components.	123
8-3. Maintenance Services.	125
8-4. Important Reminders for Reassembly and Installation.	127
8-5. Ignition Timing	128
8-6. Replacement of Distributor Driven Gear.	130

8-1. Description

The principal components of the ignition system are, as shown in the circuit diagram of Fig. 8-1, the spark plugs, distributor, contact-breaker, ignition coil and, as the source of igniting energy, the battery. Note that the ignition coil has two windings, primary and secondary.

Current from the battery flows through the primary winding and then the contact-breaker; the contact point in the breaker opens and closes to interrupt this current intermittently.

Each time the primary current is interrupted, a very high voltage develops in secondary winding. It is this intermittent high voltage that the distributor passes sequentially to the four spark plugs to fly a spark across the gap in each, one plug a time.

The distributor is a sort of rotary switch, whose rotor connects the four plugs, one at a time, to secondary winding of the ignition coil through the wires called "high-tension" cords. Note that there are one high-tension cord, from secondary winding to the center of the distributor cap, and four more high-tension cords between the spark plugs and the four terminals on the cap.

The resistor, connected in series to primary winding, serves to reduce the inductance of primary winding so that the high voltage generation in secondary winding will be stabilized.

NOTE:

Whereabouts of terminal connections are clearly indicated in the diagram below. When inspecting the electrical wiring, refer to this diagram and check to be sure that each connection is tight. Examine the cords for torn insulation and for evidence of grounding.

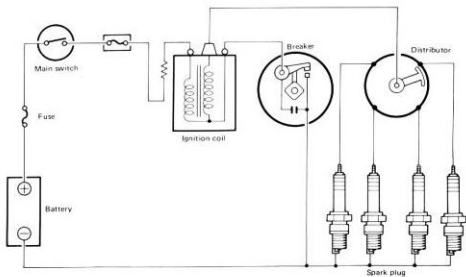

Fig. 8-1

8-2. Description of Components

Distributor

Fig. 8-2 shows the distributor unit in section to expose its internal mechanisms to easy viewing. The shaft is driven from engine crankshaft through worm gearing, and rotates once for every two revolutions of the crankshaft.

Inside the cap are four side electrodes (for spark plugs) and one center electrode (to which the secondary side of the ignition coil is connected). The arm of the rotor, mounted on the shaft, touches the side electrodes one by one "distribute" the high voltage to the spark plugs.

Immediately below the distributing mechanism is the contact-breaker, whose cam, mounted on the shaft, actuates the breaker arm to make and break the primary current circuit for the purpose already mentioned. The condenser (capacitor) secured to the distributor body is for absorbing the current surge, which would otherwise result in a sparking across the contact point gap. The surge occurs every time the contact point is opened, and is due to, so to say, the inertia of electric current. The object served by the condenser is obvious; it is to prevent the point faces from getting burnt by sparking.

Below the contact-breaker is the ignition timing advancer, which operates on the principles of centrifugal governor action. The advancer will be described next.

Distributor data	
Cam dwell angle	$52^{\circ} \pm 3^{\circ}$
Condenser capacitance	0.25 microfarad
Timing advance	10° B.T.D.C. below 850 rpm
Number of gear teeth	13
Direction of rotation	Clockwise, as viewed from top

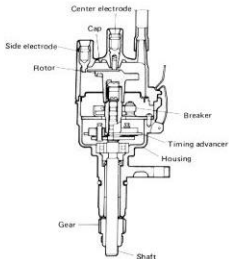

Fig. 8-2

Ignition coil

The ignition coil is a sort of miniature transformer and, as such, has an iron core around which two coils are wound — primary and secondary windings mentioned above. The two are so close to each other that a sudden change in the magnetic flux produced by “primary current” flowing in primary winding (in a less number of coil turns) induces a very large electromotive force (voltage) in secondary winding (in a greater number of coil turns). These live parts are housed in a tight, insulator case topped by the cap mentioned above. Note that the cap has three terminals: one high-tension terminal and two low-tension terminals.

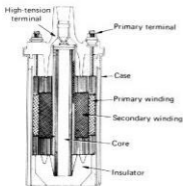

Fig. 8-3

Timing advancer

The distributor shaft, from its driven-gear end to the rotor-carrying end, is not a single solid piece; actually this shaft is in two pieces connected together through the timing advancer. The advancer is essentially a flyweight mechanism. Timing advancing action is accomplished by twisting the top shaft piece relative to the bottom one in the direction of shaft rotation.

The contact-breaker cam, mentioned above, for actuating the breaker arm is mounted on the top piece. The twisting movement is produced by the speed-dependent radial (or spreading) movements of the two flyweights.

The advance mechanism starts operating at 800 to 1,200 rpm of rising engine speed, and ceases to advance the ignition any further at about 5,500 rpm. Fig. 8-4 shows the relationship between engine speed and ignition-timing crank angle.

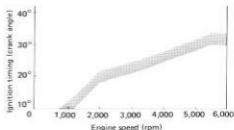

Fig. 8-4

Spark plugs

Each new machine shipped from the factory is fitted with standard plugs, BPR-5ES of NGK or W16EXR-U of NIPPON DENSO make. This plug is expected to serve well under a wide range of duty conditions but may tend to become sooty or wet under extreme duty condition.

If the standard plugs are found to remain sooty or wet, they should be replaced by hot-type plugs.

	Hot type	Standard type	Cold type
NGK	—	BPR-5ES	BPR-6ES
Nippon Denso	W14EXR-U	W16EXR-U	W20EXR-U

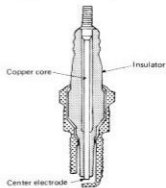

Fig. 8-5

8-3. Maintenance Services

Distributor cap

Leakage of high-tension energy for ignition shows up as misfiring in the engine. It occurs at any part of the high-tension line where insulation has failed or in a dirty distributor cap, that is, an internally dirty cap.

A wider spark gap in the plug, a condition often found in poorly cared spark plugs, promotes the tendency of high-tension energy to find a short-cut to ground.

Cleanliness is very important for the distributor cap. With a clean dry cloth, wipe off dust or grime, if any, and inspect for any damaged (scarred, scratched or cracked) part or any part evidencing high-tension leakage inside the cap. Be sure to replace such parts.



Fig. 8-6

Distributor driven gear

Inspect the gear teeth for wear, and see if the backlash is normal or not. Excessive backlash can be told by turning the shaft back and forth, with its driven gear in mesh with driving gear. Maladjusted ignition timing is often due to excessive tooth wear in this gearing and, in such a case, can be corrected by replacing the driven gear.

CAUTION:

About 90 cc (3.04/3.16 US/Imp oz) of engine oil will come out of the distributor drive gear case when the distributor assembly is removed from the case. Never allow this oil to find its way into the clutch case. Attach the ignition-timing inspection cap to the transmission case and place a properly shaped pan to catch the oil. After re-installing the distributor assembly, be sure to add make-up engine oil.



Fig. 8-7

Spark plugs

The spark gap specification is 0.7 ~ 0.8 mm (0.027 ~ 0.031 in). Be sure to use a thickness gauge in checking the gap. A wide gap is just as bad as a narrow gap. The 0.7 ~ 0.8 mm (0.027 ~ 0.031 in) gap will produce the right kind of sparks needed by the air-fuel mixture in this engine.



Fig. 8-8

Contact point faces

In the contact breaker, push the breaker arm with your fingertip just a little so that you can see the point faces. If the faces are oily, clean; if roughened, smoothen by grinding. In most cases, the point faces can be reconditioned by grinding with a file or oil stone. Points worn beyond repair must be replaced.

The illustration, below, tells what must be done in each case but the last one showing a pair of properly aligned, smooth faces. Wear or burning is hard to occur in the contact point whose point faces are in the condition labeled "good."

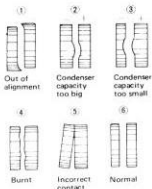

Fig. 8-9

Checking the primary circuit for fault

If the engine misfires or does not fire up at all where its spark plugs have just been checked to be in good condition, the first step of locating the cause is to check the primary circuit (between distributor and ground) for continuity by using a circuit tester as shown. Since the contact point is open, the tester should indicate discontinuity (infinitely large resistance); if continuity is noted, it means that there is a fault somewhere along the primary circuit, which could be in the ignition coil, condenser or elsewhere.

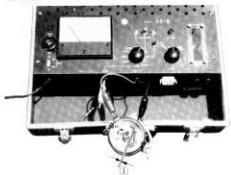

Fig. 8-10 ① Open

Condenser

Check the condenser for capacitance by using the electro-tester. You may do so with the condenser in place or removed. When checking it in place, that is, as mounted on the distributor, be sure to have the contact point opened. A condenser not meeting the following capacitance specification must be replaced:

Condenser capacitance specification	0.25 microfarad
-------------------------------------	-----------------

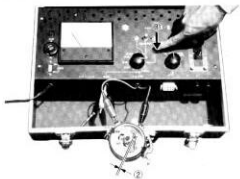

Fig. 8-11 ② Open ③ Push

Ignition coil

(1) Sparking performance test

The purpose of this test is to see if the ignition coil is capable of producing high voltage surges forceful enough to fly good sparks at the ignition coils at all times, particularly when its temperature has risen to the normal operating level. Use of the electro tester is assumed for this test. With the ignition coil connected to the tester, as shown, let the spark fly across the three-needle gap. Continue this testing for about three minutes so that the coil will get warm to simulate the normal operating condition. The coil may be deemed to be in good condition if the sparking is stable, without any misses. In the use of the electro tester for this purpose, do not enlarge the three-needle gap wider than 7 mm (0.27 in.).

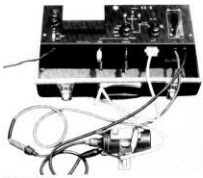

Fig. 8-12

(2) Resistance measurement

Measure the ohmic resistances of primary and secondary windings in the ignition coil. If the readings are in agreement with the prescribed values, indicated below, the coil may be judged to be in good condition. Take readings when the coil is hot, about 80°C (176°F); this is because we are interested in the performance of the coil at the normal operating temperature, not of a cold coil.

Primary winding resistance	About 3 ohms (inclusive of the 1.5-ohm resistor)
Secondary winding resistance	About 8 kilohms



Fig. 8-13

8-4. Important Reminders for Reassembly and Installation

Distributor

A definite sequence must be followed in inserting the distributor into the distributor gear case. This is because the relative angular positions of distributor rotor and crankshaft are essential factors of ignition timing. The sequence is as follows:

- (1) Turn over crankshaft in normal direction (clockwise as viewed from front side) to bring timing mark 10° ① (on flywheel) to the mark ② provided on transmission case, making the two marks line up. See Fig. 8-14.

CAUTION:

Remove the cylinder head cover and check to be sure that No. 1 cylinder rocker arms are down and not riding on cam lobes when the two marks ① ② are in register with each other; if the rocker arms are found to be riding on the lobes, turn over crankshaft another rotation (360°) so that the arms will be on the low parts of the cams.

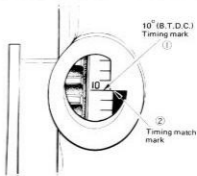

Fig. 8-14

- (2) Remove the distributor cap. Turn the rotor to make the end face ③ of rotor flush with mark ④ embossed on the distributor housing, as shown in Fig. 8-15.



Fig. 8-15

- (3) Insert the distributor into the distributor gear case, indexing the center line ⑤ of distributor flange to the distributor mounting screw hole. Secure the distributor snugly and, at the time of timing the ignition, adjust its position.

High-tension cords

The distributor cap has four terminals to which the four high-tension cords are connected, one cord for one spark plug. Each terminal is identified by a number (1, 2, 3 or 4) marked close to the terminal.

When installing these cords to connect the plugs to the distributor, be sure to be guided by the identifying numbers: terminal 1 is for No. 1 cylinder plug, terminal 2 for No. 2 cylinder plug, and so on.

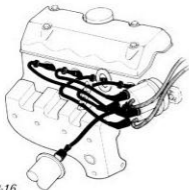

Fig. 8-16



Fig. 8-17

(1) Checking and adjusting with timing light

CHECKING:

Connect the timing light to the high-tension cord of No. 1 cylinder spark plug. Start up the engine and hold it at a speed not higher than 850 rpm. Under this condition, observe the timing marks under light. (The 10° timing mark (4) on flywheel will appear stationary.)

If mark (4) is in register with the mark (5) on transmission case, the ignition is timed correctly. See Fig. 8-18.

8-5. Ignition Timing

Specifications

Ignition timing	10° B.T.D.C. below 850 rpm
Ignition order	1 - 3 - 4 - 2
Breaker point gap(3)	0.4 ~ 0.5 mm (0.016 ~ 0.019 in.)

Checking methods

Check to be sure that the point gap is within the specified range, from 0.40 to 0.50 mm (0.016 ~ 0.019 in.) and then check the ignition timing on No. 1 cylinder. To adjust the point gap, loosen screws (1) and move the stationary point with plain screwdriver inserted into slit (2).

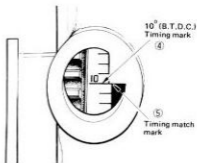
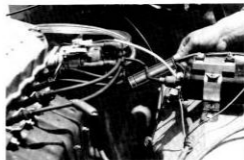

Fig. 8-18

To see whether the advancer in the distributor is working properly or not, raise the speed gradually while observing the timing marks and checking the speed, and compare the readings (on ignition-timing crank angle and engine speed) with the characteristic curve of the graph given in Fig. 8-4.

An appreciable difference between the way the ignition advance is increased and what the graph shows signifies that the governor weights in the distributor are set improperly or their return springs are fatigued or broken. If such a difference is noted, service the governor and replace the springs or any other part, as necessary.

ADJUSTING:

Upon noting that the ignition is not timed to the specification, proceed as follows:

- 1) Make sure that the breaker point gap is set right, that is, between 0.4 and 0.5 mm (0.016 - 0.019 in.).
- 2) Loosen the distributor clamp bolt, and turn (or angularly displace) the distributor housing a little at a time until the marks ④ ⑤, mentioned above, line up under lamp light.

NOTES:

- Turning the housing clockwise retards the timing and vice versa.
- After tightening the clamp bolt, check the timing once again.

- (2) Checking and adjustment with the timing tester

The timing tester has a built-in buzzer. Connect one of its leads to the primary-circuit terminal of the distributor and the other lead to the distributor body. Slowly turn the crankshaft by rotating the cooling fan clockwise with the hand while watching the timing marks. (Have the ignition switch turned off.)

The buzzer should start sounding off just when the marks come into register, indicating that the engine is set for the specified timing.

CAUTION:

With timing marks ① ② lined up as shown in Fig. 8-19, remove the cylinder head cover and check to be sure that No. 1 cylinder rocker arms are not riding on cam lobes. If the arms are up, turn over crankshaft by one rotation (360°) clockwise (as viewed from front side). This turning should cause the buzzer to sound off just when the marks come into alignment.

NOTE:

The two tester leads are given polarity signs, (+) to one and (-) to the other lead; connect the red lead to (+) cord, and the black lead to (-) cord, of the distributor.

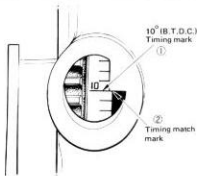

Fig. 8-19



Fig. 8-20 (A) Timing tester (09900-27003)

ADJUSTING:

Upon noting that the ignition is not timed to the specification, proceed as follows:

- 1) Make sure that the breaker point gap is set right, that is, between 0.4 and 0.5 mm (0.016 - 0.019 in.).
- 2) Bring timing mark ① into alignment with mark ②, as shown in Fig. 8-19. Mark ① represents the 10° crank angle.
- 3) Loosen the distributor clamp bolt, and slowly rotate the distributor housing until the buzzer starts sounding off. Hold the distributor right there and tighten the clamp bolt.

NOTES:

1. Turning the housing counterclockwise advances the timing and vice versa.
2. After tightening the clamp bolt, check the timing once again.

CAUTION:

Distributor gear case

About 60 cc (2.03/2.11 US/Imp oz) of engine oil must be fed into the distributor gear case after servicing this case, that is, removing and putting it back. Be sure to add this much oil before starting the engine for the first time after servicing. For the filling point, remove the bolt on the case and use the bolt hole.



Fig. 8-21

8-6. Replacement of Distributor Driven Gear

Replacing a worn-down driven gear (a part of the distributor assembly) is not enough. Inspect the drive gear, too, and replace it if it is badly worn down. The drive gear can be removed from the camshaft.

Worn gears in the distributor drive are likely to disturb the ignition timing and must be replaced.

When pressing the replacement drive gear onto camshaft, be sure to position the gear angularly as shown in Fig. 8-21. Note that the tooth root is radially centered on the center line through the keyway provided in camshaft.

NOTES:

1. Before removing the drive gear from the camshaft, scribe a match mark on this shaft and, when mounting the replacement drive gear, refer to this mark.
2. There is no need to discriminate between the two end faces of the drive gear: the gear may be fitted with either end held foremost.

9. STARTER MOTOR

9-1. Description	132
9-2. Specifications	132
9-3. Cranking Action	133
9-4. Removal	134
9-5. Disassembly	135
9-6. Maintenance Services	136
9-7. Important Reminders for Starter Motor Reassembly	138

9-1. Description

A shift-lever type starter motor is used for cranking the engine. The motor is mounted on the crank case, with its drive pinion meshed with the ring gear of the flywheel. In the following illustration, note that the whole motor assembly inclusive of the magnetic switch and lever mechanism is enclosed.

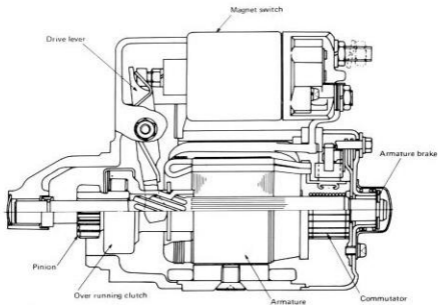

Fig. 9-1

9-2. Specifications

Voltage	12 volts
Output	0.8 kW
Rating	30 seconds
Direction of rotation	Clockwise as viewed from pinion side
Brush length	16 mm (0.63 in.)
Number of pinion teeth	9
No-load characteristic	50 A maximum at 11 volts, 5,000 rpm minimum
Load characteristic	270 A maximum at 9.5 volts and 0.7 kg-m torque, 1,200 rpm minimum
Locked rotor current	600 A maximum at 7.7 volts, 1.3 kg-m minimum
Magnetic switch operating voltage	8 volts maximum

9-3. Cranking Action

Starting up the motor

Turning on the starting switch results in a small current flowing through the holding coil and another through the pull-in coil, both in the magnetic switch. The former current flows direct into ground, but the latter flows through motor armature and field. In other words, motor begins to run. In the magnetic switch, the two coils energized—pull-in coil and holding coil—develop a combined magnetic pull, by which the moving core is pulled against the force of the spring and moves toward the right (in the illustration). At this time, the motor armature is running but slowly because of the small initial current. As the moving core is forced toward the right, its left end turns the shift lever around its pivot, so that the bottom end of the lever pushes the clutch toward the left. Since the clutch is splined to the motor shaft and because the motor shaft is rotating, the clutch advances toward the left as assisted by the helical splines.

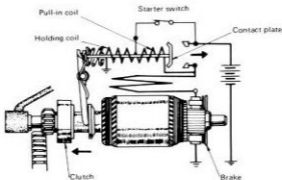

Fig. 9-2

Pinion meshing with the ring gear

The pinion may mesh into the ring gear smoothly or may bounce on the ring gear, depending on the relative positions of their teeth. In the latter event, the springs mounted on the clutch absorb the shock and, since the pinion is rotating and being pushed, its teeth will eventually mesh into those of the ring gear. In either case, the shift lever is allowed to turn fully and permit the moving core to be kept pulled all the way toward the right. When this happens, the main contactor of the magnetic switch closes to connect the starter motor direct to the battery. Consequently, a very large current—load current—flows through the motor to develop a high cranking torque for driving the engine crankshaft through the drive pinion and ring gear.

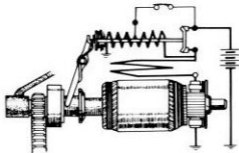

Fig. 9-3

Engine cranking

When the motor is cranking the engine with full force, the pull-in coil is bypassed or shunted but the holding coil remains energized to hold the moving core in its shifted position. Under this condition, the shift lever is pushing the pinion by overcoming the force of springs.

As the engine fires up and begins to run steadily and if the starting switch is kept closed, the ring gear starts driving the pinion. When this occurs, the pinion merely spins on the motor shaft without transmitting this reverse drive to the motor. This is because the clutch is of overrunning type.

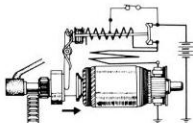

Fig. 9-4

Terminating cranking operation

Turning off the starting switch de-energizes (shutting off the current) the holding coil so that the pull hitherto acting on the moving core disappears. By the force of the spring, then, the shift lever is turned back and the moving core is forced toward the left to open the main contactor. This shuts off the load current, and the drive pinion, shift lever and moving core go back to their original positions.

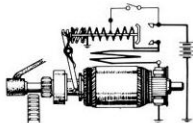

Fig. 9-5

9-4. Removal

- 1) Disconnect battery cable from the negative terminal of the battery.
- 2) Disconnect BLACK/YELLOW lead wire and power circuit wire (leading to the plus side of the battery) from the starter motor.
- 3) Remove the two bolts securing the starter motor assembly to the crank case, and take off the starter motor.

9-5. Disassembly

- 1) Remove the nut securing the end of the field coil lead to the terminal on the head of magnetic switch.
- 2) Take off the magnetic switch ① from the starter motor body by removing the two mounting screws.

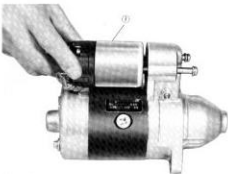

Fig. 9-6

- 3) Remove the bearing cover ②, and take out lock plate brake spring ③ and rubber ④



Fig. 9-7 ⑤ Clip

- 4) Disassemble the brush holder section in the following sequence:
 - (1) Remove two through bolts.
 - (2) Detach commutator end frame.
 - (3) Draw brushes out of the holder.
 - (4) Take out the brush holder.

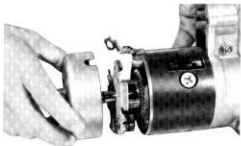

Fig. 9-8

- 5) Remove the case complete with field coils.
- 6) Pull off the set pin from shift lever, and take out the rubber and plate inside the housing.
- 7) From the housing, take out the armature, starter clutch and shift lever.



Fig. 9-9

- 8) Draw off the starter clutch, as follows:
 - (1) Draw stop nut toward the clutch side.
 - (2) Remove snap ring and slide off clutch.

9-6. Maintenance Services

In the event the starter motor is found unable to crank the engine, the first thing to be checked is whether the drive pinion plunges out. If the pinion does not plunge out, then the magnetic switch must be checked.

If the pinion plunges out satisfactorily, then the inability of the motor to crank the engine is likely to be due to some defective condition in the commutator or in the armature, provided that the battery is in good condition and that the circuit for applying the battery voltage to the motor is free from any open or fault. Having narrowed the scope of search for the cause of trouble to the motor proper, proceed as follows:

Checking the field coils

Check to be sure that the field circuit is neither grounded or open-circuited. This can be effected by using a circuit tester as shown. If continuity is indicated by the tester hooked to the housing or frame, it means that the insulation has failed, resulting in a grounded field coil. Such a fault can be corrected by repair in most cases.



Fig. 9-10

Checking the armature

- Using the circuit tester, see if there is any continuity between commutator and armature core. The tester will indicate infinite resistance if the insulation is in sound condition.



Fig. 9-11

- Again using the tester, check for continuity between each pair of adjacent commutator segments. If discontinuity is noted at any part of the commutator, replace the whole sub-assembly of the armature.



Fig. 9-12

Servicing the commutator

- If the surface of the commutator is gummy or otherwise dirty, wipe it off with a cloth dampened with gasoline. If the surface is coarsened or in burnt condition, smoothen it by grinding with sandpaper. If the surface is grooved deep, it may be necessary to remove the groove marks by turning the commutator in a lathe; such turning is often successful in reconditioning the commutator if the extra stock necessary for removal by cutting is available without reducing its diameter to the limit.

Commutator diameter	Standard	Service limit
	32.5 mm (1.28 in.)	30.5 mm (1.20 in.)

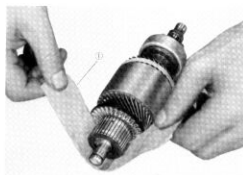

Fig. 9-13 ① Sandpaper

- Make sure that the mica between each pair of adjacent segments is undercut to the prescribed depth. The conventional undercutting technique is to be used in repairing the commutator.

Mica undercut	Standard	Service limit
	0.5 ~ 0.8 mm (0.02 ~ 0.03 in.)	0.2 mm (0.007 in.)

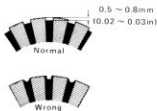

Fig. 9-14

Testing the magnetic switch

Before separating the magnetic switch from the motor proper just removed from the crankcase, test the switch by connecting the battery to the switch, as shown, to see if the drive pinion jumps out when the battery voltage is applied. (With the positive terminal of the battery cable end.) With the switch coils in sound condition, the drive pinion will jump out and, even when the main circuit is opened at "A", will remain in "jumped out" position. If undoing the connection at "A" causes the drive pinion to retract, it means that the holding coil is defective.



Fig. 9-15

Servicing the brushes

Check the length of each brush. If brushes are worn down to the service limit, replace them.

Brush length	Standard	Service limit
	16 mm (0.63 in.)	12 mm (0.47 in.)



Fig. 9-16

Servicing the brush holders

Make sure that the insulation between the two brush holders, positive and negative, is in good condition. This should be verified with the use of the circuit tester. If any continuity is noted, repair the insulation.

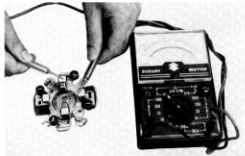

Fig. 9-17

9-7. Important Reminders for Starter Motor Reassembly

Various parts of the starter motor assembly need lubrication at each overhaul. The lubrication points are illustrated below: (Also required is locking by punching.)

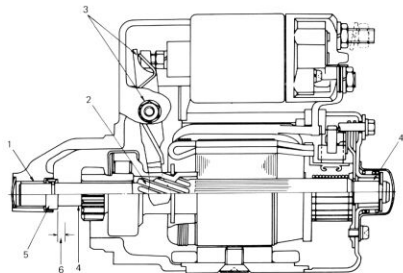

Fig. 9-18

- 1) Give grease to the bush in the drive housing.
- 2) Grease the helical splines before mounting the clutch sub-assembly.
- 3) Grease the sliding or contacting surfaces associated with shift lever.
- 4) Grease the bush fitted into the end frame and also the armature shaft end inserted into this bush.
- 5) After installing the stop nut, lock it by staking at two places with a punch.
- 6) Adjust the length of the moving stud so that the clearance between the stop nut and the pinion in plunged-out condition will be from 1 to 4 mm (0.04 to 0.16 in.). To check, run the motor in no-load condition to plunge out the pinion and wait till the motor speed settles.

10. CHARGING SYSTEM

10-1. Description	140
10-2. Charging Operation	141
10-3. Alternator	143
10-4. Alternator Regulator	147
10-5. Main Fuse	150
10-6. Battery	150

10-1. Description

The charging system consists of the alternator complete with a means of rectification for producing DC output power, and the two-element regulator unit for controlling the voltage.

In the alternator, the armature is stationary; it consists of three coils mounted on the stator in such a way as to produce three-phase alternating voltage. This voltage applies to the rectifier for full-wave rectification. The rectifier delivers power in the form of direct current.

Against the stationary armature, revolving magnetic fields are produced by the field winding carried in the rotor. This feature of construction of the alternator strikes a distinct contrast to the dynamo (DC generator), in which the field is in the stator while the armature is in the rotor.

The magnitude of three-phase AC power available from the alternator to its rectifier is directly proportional to rotor speed and field (excitation) current. It is the function of the regulator unit to control the field current automatically in such a way that the output voltage unit to control the field current automatically in such a way that the output voltage remains constant; another function is to control the circuit of the charge warning light. Thus, the regulator unit has two elements; one is voltage regulator for performing the first function and the other is voltage relay for the second function.

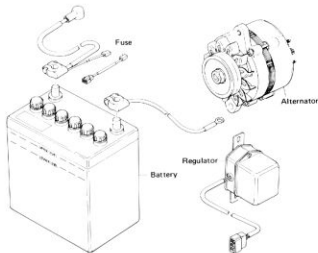

Fig. 10-1

10-2. Charging Operation

The following description of the system operation is referenced to the circuit diagram indicated in Fig. 10-2. Closing the ignition switch connects the charge warning light to the battery; a small current flows through the light, lighting this light to signify that the alternator is not charging the battery, and through the contact point of voltage relay to ground. Another current flows from the battery through the contact point of voltage regulator into the field winding in the alternator rotor, thereby producing magnetic fields around the rotor. These fields, which are stationary at this time because the rotor is not running, link the armature coils and the rotor poles through the air gap between stator and rotor.

Under these conditions, suppose the engine is started up. The rotor begins to run, and its magnetic fields revolve to "cut" the three armature coils in succession. In each armature coil, an electromotive force is generated by electromagnetic induction. This force changes its direction alternately. Consequently, the three armature coils apply three alternating voltages to the rectifier. Viewed collectively, these voltages constitute the three-phase output voltage of the alternator.

The rectifier consists of three pairs of rectifying diodes, forming three one-way paths of current for full-wave rectification to convert the alternator output power into a direct current power, which is available from the "B" terminal of the alternator-rectifier unit, relative to "E" (ground) terminal.

As the engine picks up speed, the electromotive force induced in each armature coil increases, so that the output voltage appearing at terminal "B" (relative to terminal "E") becomes high enough to "push" electricity into the battery through its positive terminal. In other words, the battery begins to draw a charging current.

Let's take a look at the pressure coil of the voltage relay. One end of this coil is connected to terminal "E" and the other end to the neutral point "N" of the three armature coils. Potential level of "E" (ground) is now so much lower than that of "N" that a current flows in the pressure coil to develop a magnetic pull on its armature carrying point "P5". Consequently, point "P5" separates from point "P4" and touches point "P6"; the charge warning light thus becomes shunted and stops burning to signify that the battery is getting charged.

During the early stage of engine starting, the alternator output voltage may be lower than the battery voltage; even in such a case, no current flows from the battery into the alternator because of the rectifier diodes. The reason why a cutout relay is not used here is explained by the presence of the diode rectifier.

The function of the voltage regulator with its voltage coil is to alter the path of field (excitation) current for the field coil, in order to maintain the alternator output voltage at a relatively constant level. When this voltage rises owing to a rise in engine speed, the voltage coil pulls point "P2" away from point "P1", thereby introducing the control resistor "R1" into the field circuit. Field current falls slightly because of this resistance and, consequently, the output voltage falls to the normal level. If the engine picks up speed further, the magnetic pull developed by the voltage coil increases to bring point "P2" into contact with "P3", thereby shunting the field coil to reduce the field current to zero. Under this condition, voltage generation in the alternator is dependent on the residual magnetization of the rotor, which is small enough to keep down the output voltage to the normal level.

The foregoing description of the voltage regulator operation may be summarized as follows: the regulator controls the alternator output voltage by controlling the field current in three steps; first allowing a full field current to flow; secondly, by inserting a resistor into the circuit to reduce the field current; and thirdly, by shunting the field coil to reduce the current to zero, all for maintaining the output voltage at a relatively constant level.

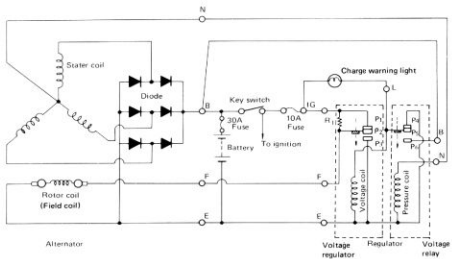

Fig. 10-2

10-3. Alternator

Description

In order to distinguish it from conventional automotive dynamos, the AC generating device is called an alternator for it produces a DC output from three alternating currents generated in its winding.

The alternator consists of: the rotor (which produces revolving magnetic fields), stator (which is a series of coils disposed and arranged to form three coil groups), two slip rings and two brushes (through which DC excitation current is fed into the field winding of the rotor), and the rectifier (which consists of 6 semiconductor diodes, and is built in the alternator).

In operation, the revolving magnetic fields "cut" the stator coils. In other words, the three groups of coils experience changes in magnetic flux. By the flux changes, an alternating electromotive force (emf) is induced in each coil group. Thus, three alternating voltages are available from the stator.

The six diodes are arranged so that they "rectify" or convert the three alternating outputs into a DC output. Three-phase full-wave rectification is effected by the built-in rectifier.

In terms of electric current, a diode is a circuit element that passes the current only in one direction. Of the six diodes, three are arranged to pass currents in the same direction, and the remaining three in the opposite direction. Since three alternating currents undergo full-wave rectification and are combined into one by superposition, the DC output of this alternator is much steadier and carries much less pulsating or ripple components than a DC output made available by full-wave rectification of a single-phase alternating current.

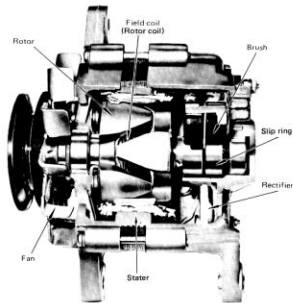

Fig. 10-3

Data and Specification

Nominal operating Voltage	12 Volts
Maximum alternator output	35A
Polarity	Negative ground
Effective pulley diameter	70 mm (2.75 in.)
No-load alternator speed	1,050 ~ 1,250 rpm, 14 Volts at normal temperature
Full-load alternator speed	4,000 rpm maximum, 35A, 14 Volts at normal temperature
Direction of rotation	Clockwise as viewed from pulley side
Maximum permissible alternator speed	13,000 r/min (rpm)
Working temperature range	-40°C ~ 80°C (-104°F ~ 176°F)
Rectification	Full-wave rectification

Removal

- (1) Disconnect the positive battery cable from the battery.
- (2) Disconnect from the alternator the white cord and circuit coupler.
- (3) Remove the bolts securing "V" belt adjusting arm and alternator and take down the alternator.

Alternator Disassembly

Remove the nut securing the fan to the rotor shaft. To do so, the shaft must be held rigid and steady by using a special tool (A).

Hexagon wrench, 6 mm (09911-70120)

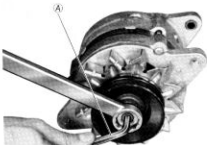

Fig. 10-4

Remove the 3 bolts fastening the end frame to the rotor housing; tap on the edges of the end frame with a wooden mallet to separate it from the housing, thereby severing the rotor from the stator.

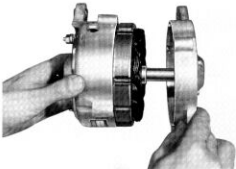

Fig. 10-5

Draw out the rotor. It may be necessary to lightly tap on the core and housing.



Fig. 10-6

Remove the 3 nuts securing the rectifier holder in place, and one other nut holding down the terminal insulator. Remove the rear end cover.

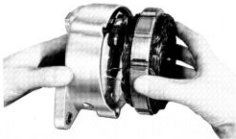

Fig. 10-7

Remove the brush holder from the stator.



Fig. 10-8

NOTE:

The alternator is to be reassembled by reversing the foregoing sequence of steps. Before inserting the rotor into the housing, be sure to have the brushes installed in the holder. (Use a proper size rod \bar{A} , manipulating it from the rectifier side, to set the brush in the holder.)



Fig. 10-9

Maintenance Services

(1) Rotor

- Testing the rotor for open circuit
Check to be sure there is continuity between the two slip rings when tested as shown. Absence of continuity means that the field coil is open-circuited and must be replaced.

Ring-to-ring circuit resistance	4 ~ 5 ohms
---------------------------------	------------



Fig. 10-10

- Testing the rotor for grounding
Check to be sure there is no continuity between the slip ring and the rotor shaft when tested as shown. Presence of any continuity means that the insulation on the field coil has failed, making it necessary for the rotor to be replaced.



Fig. 10-11

(2) Stator

Check to be sure there is no continuity between the stator core and each armature coil; any continuity noted means that the coil is grounded. A grounded armature coil can be corrected by locating the faulted point and repairing the fault.



Fig. 10-12

(3) Brushes

Check each brush for wear by measuring its length, as shown. If the brush is found worn down to the service limit, replace the brush and holder altogether.

Brush length	Standard	Service limit
	16.5 mm (0.65 in.)	11.0 mm (0.45 in.)

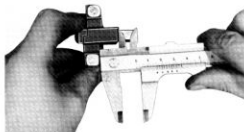

Fig. 10-13

(4) Rectifier

The rectifier is to be checked with the circuit tester for continuity in one direction and non-continuity in the other direction.

Put one tester lead to terminal "B" and the other lead to terminal "N"; then swap the two leads. Of the two tester indications, one should be about 20 ohms, meaning continuity, and the other should be infinity (non continuity.).

Put one tester lead to terminal "N" and the other lead to terminal "E"; then swap the two leads. In this case, too, the two tester indications should be similar to those mentioned above.

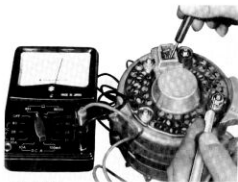

Fig. 10-14

(5) Alternator load performance

With the alternator-rectifier unit in place, run the engine in a speed range of 3,000 to 4,000 rpm, and check the alternator output voltage and current. Compare the readings against the prescribed values, indicated below. An output current which is small means the possibility of the rectifier being defective, any of the stator (armature, coil open-circuited, or an insulation failure resulting in a grounding fault.

Standard output voltage and current	13.8 ~ 14.8 volts, 20A minimum
-------------------------------------	-----------------------------------

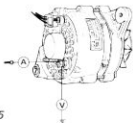

Fig. 10-15

10-4. Alternator Regulator

In the two-element regulator, one coil acts as voltage limiter or regulator and the other coil as relay for controlling the charge warning light. It should be noted in the circuit diagram that the magnetic pull developed by the voltage coil to move its moving point "P2" is roughly proportional to the alternator output voltage, whereas the magnetic pull developed by the pressure coil of the relay is dependent on the potential level of neutral point "N" of the armature with respect to the ground. A clear understanding of these relations is essential in checking, testing and servicing the regulator unit.

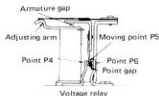
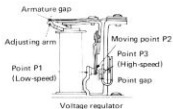

Fig. 10-16

Specifications

Regulated voltage	13.8 ~ 14.8 volts
Voltage-relay cut in voltage	4 ~ 5.8 volts

Maintenance services

- (1) Voltage-regulator limiting action test
Hook up a voltmeter, inserting it between the alternator "B" terminal and ground, and run the engine within a range of 2,000 to 3,000 rpm, while reading the voltmeter indication. The voltage read is the charging voltage as limited by the action of the voltage regulator; the reading should be within the prescribed range, which is indicated below. If the charging voltage is found too high or too low, adjust it by bending the adjusting arm of the voltage regulator.

Prescribed range of charging voltage	13.8 ~ 14.8 volts for 2,000 ~ 3,000 engine rpm
--------------------------------------	--

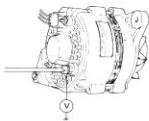

Fig. 10-17

- a If the charging voltage is noted to oscillate or otherwise be unstable, it is most likely that the contact point faces in the voltage regulator are dirty or roughened. Cleaning and smoothening the faces will remedy this malfunction.
- b If the charging voltage is too high, the possible causes are as follows:
 - Armature gap is too wide on low-speed side or high-speed side in the voltage regulator.
 - Contact resistance at high-speed side point is too large.
 - The coil of voltage regulator or relay is open-circuited.
 - Open circuit in the line to "N" or "B" terminal of the regulator unit. (Refer to Fig. 10-19)
 - Contact pressure is too high on low-speed side point.
 - Imperfect grounding of the regulator unit.

- (2) Continuity test on field coil
Using the circuit tester, check for continuity between the "E" and "F" terminals of the alternator, as shown. The tester should indicate continuity with a resistance value meeting the following specification:

Standard field circuit resistance	6 ~ 9 ohms
-----------------------------------	------------

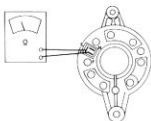

Fig. 10-18

- a If the resistance value noted is too small, it is likely that there is a short circuit through insulation layers in the coil.
 - b If the resistance value noted is too large, the following possibilities must be considered:
 - An open-circuit is developing in the field coil.
 - The brushes are not seated properly on the slip rings.
 - Brushes or slip rings are burnt.
- (3) Checking terminal-to-terminal resistances
Pull off the connector from the regulator unit, remove the cover, and check the resistance between terminals. Refer the resistance readings to the following chart to diagnose the internal condition of the regulator unit:

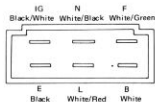

Fig. 10-19

Guide on regulator diagnosis				
Terminal checked	State of vol. relay	State of vol. regulator	Normal resistance value (ohms)	Diagnosis
IG-F		Standstill	Zero	If not zero, point contact is defective on low-speed side.
		Operated	Approx. 11	If infinity is noted, control resistor is open-circuited.
L-E	Standstill		Zero	If not zero, relay contact point is not closing fully.
	Operated		Approx. 100	If zero, relay point faces are fused together. If infinity is noted, voltage coil is open-circuited.
N-E			Approx. 24	If zero, pressure coil is shorted. If infinity, voltage coil is open-circuited.
B-E	Standstill		Infinity	If not infinity, relay point faces are fused together.
	Operated		Approx. 100	If zero, voltage coil is shorted. If infinity, voltage coil is open-circuited or contact action of the point is defective.
B-L	Standstill		Infinity	If not infinity, relay point faces are fused together.
	Operated		Zero	If not zero, contact action of the point is defective.

NOTE:

In the above chart, "standstill" means that the regulator unit is in de-energized state; "operated" means that the armature is manually (with a fingertip) actuated as if it were pulled in by the coil.

(4) Gap adjustment

Ⓐ Voltage relay

Using a thickness gauge, check the two gaps, point gap and armature gap. Refer the gauge readings to the specification value, below, and adjust the gaps as necessary.

Gap specifications	
Armature gap	Approx. 0.6 mm (0.023 in.)
Point gap	Approx. 0.4 mm (0.015 in.)



Fig. 10-20

Ⓑ Voltage regulator

Two gaps are to be checked: point gap, and armature gap. Use a thickness gauge, and compare the readings taken against the following specifications. Adjust the gaps as necessary.

Gap specifications	
Armature gap	Approx. 1.1 mm (0.043 in.)
Point gap	Approx. 0.5 mm (0.019 in.)



Fig. 10-21

10-5. Main Fuse

The main fuse, located in the path of current to and from the battery, is of fusible link type, whose conductor wires are copper-nickel alloy in material and are sheathed in double layer of insulation. It interrupts overcurrent by the melting action of its conductor.

Interrupting capacity of main fuse	30A
------------------------------------	-----

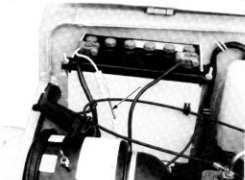

Fig. 10-22

10-6. Battery

1) Battery specifications

Model	NS 60
Rated capacity	45AH, 12 Volts
Electrolyte	3.1 litres (6.6/5.5 US/Imp. pt.)
Electrolyte S.G.	1.26 when fully charged at 20°C (68°F)

2) Care of the battery

The following information is basic in nature and is nothing new; it is merely a reiteration of what every Service shop personnel knows about the automotive storage battery. The information is intended to serve as a reminder to the reader, with a hope that he will, in turn, remind each final user of the important basic facts about the battery whenever opportunity permits him to engage in a conversation with the final user in the shop or out of the shop.

- (1) The battery is a very reliable component, but needs periodical attentions.

Keep the battery container clean; prevent rust formation on the terminal posts; keep the electrolyte up to the upper level uniformly in all cells; and try to keep the battery fully charged at all times.

- (2) Preserve the capacity of the battery.

There is a limit to the ability of the battery to hold electricity in store. This limit is called "capacity."

There are several ways for the battery to lower its capacity:

- (a) Loss of electrolyte, or fall in electrolyte level.

When this happens, the battery cannot hold so much electricity as it originally could. Handle the battery with care when you take it down. Barring the loss of electrolyte by careless spilling or otherwise, the electrolyte level goes down gradually in the battery at work because the water content of it evaporates. Periodically refill distilled water to each cell, as necessary, so that the electrolyte is always up to the specified level. Never allow its surface to fall so much as to expose the cell plates.

- (b) Overcharging the battery in place or off the machine.

In recharging the battery off the machine, caution must be exercised so as not to overcharge it. Overcharging gives rise to several complexities. For one thing, it heats up the battery to deform the battery container to result in a destroyed battery. Overcharging could occur in a battery in place if the voltage regulator is maladjusted to allow the alternator (or the dynamo in other machines) to develop too high an output voltage. For another thing, "gassing" occurs in a battery being overcharged to result in a loss of water content. One of the most serious consequences of overcharging is the swelling of positive-plate grids, causing the grids to crumble and the plates to buckle.

- (c) Undercharging the battery in place.

Regulator malfunctioning is usually the cause of the battery remaining in a state of charge far below its capacity. This condition is very undesirable in freezing weather, for the electrolyte in such a battery can easily freeze up to result in a destroyed battery. Moreover, an undercharged battery is an easy prey to a greater evil-sulfation.

- (d) Sulfation.

Let us recall the electrochemical reactions that take place in the battery during charging and discharging. As the battery gives out its energy (discharging), the active materials in its cell plates are converted into lead sulfate. During recharging, this lead sulfate is reconverted into active material. If the battery is allowed to stand for a long period in discharged condition, the lead sulfate becomes converted into a hard, crystalline substance, which will not easily turn back to the active material again during the subsequent recharging. "Sulfation" means the result as well as the process of that reaction. Such a battery can be revived by very slow charging and may be restored to usable condition but it is a damaged battery and its capacity is lower than before.

- (3) Keep the battery cable connections clean.

The cable connections, particularly at the positive (+) terminal post, tend to become corroded. The product of corrosion, or rust, on the mating faces of conductors resists the flow of current. The inability of the starter motor to crank the engine is often due to the rust formation in the battery cable connection. Clean the terminals and fittings periodically to ensure good metal-to-metal contact, and grease the connections after each cleaning to protect them against rusting.

- (4) Be always in the know as to the state of charge of the battery.

The simplest way to tell the state of charge is to carry out a hydrometer test. The hydrometer is an inexpensive instrument for measuring the specific gravity (S.G.) of the battery electrolyte. Why measure the S.G.? Because the S.G. of the electrolyte is indicative of the state of charge.

The direct method of checking the battery for state of charge is to carry out a high rate discharge test, which involves a special precise voltmeter, an expensive instrument used generally in the service shops but not recommendable to the user of the machine.

At 20°C of battery temperature (electrolyte temperature):

The battery is in FULLY CHARGED STATE if the electrolyte S.G. is 1.26.

The battery is in HALF CHARGED STATE if the S.G. is 1.220.

The battery is in NEARLY DISCHARGED STATE if the S.G. is 1.150 and is in danger of freezing.

What if the battery temperatures not 20°C (68°F)? Since the S.G. varies with temperature, you have to correct your S.G. reading (taken with your hydrometer) to the value at 20°C, and apply the corrected S.G. value to the three-point guide stated above. This manner of correction needs a chart showing the relation between S.G. and temperature. There is a simpler way: refer to the graph given below, which tells you the state of charge for a range of S.G. value and a range of temperature.

How to use the temperature-corrected state-of-charge graph.

Suppose your S.G. reading is 1.26 and the battery temperature is -5°C (23°F). Locate the intersection of the -5°C line and the 1.26 S.G. line. The intersection is "A". It is in the zone for CHARGED STATE. How much is the battery charged? To find out the answer, draw a line parallel to the zone demarcation line, extending it to the right, and see where this line crosses the percentage scale. In the present example, the line crosses at, say, 85% point. The battery is 85% fully charged.

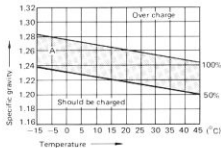

Fig. 10-23

11. CLUTCH

11-1. Description	154
11-2. Removal	155
11-3. Maintenance Services	155
11-4. Installation	157

11-1. Description

The clutch is a diaphragm-spring clutch of dry single disc type, as shown in the cross sectional view of Fig. 11-1. The diaphragm spring is of tapering-finger type, which is a solid ring in the outer diameter part, with a series of tapering fingers pointing inward. The disc, carrying six torsional coil springs, is slidably mounted on the transmission input shaft with a serration fit.

The clutch cover is secured to the flywheel, and carries the diaphragm spring in such a way that the peripheral edge part of the spring pushes on the pressure plate against the flywheel (with the disc in between). When the clutch release bearing (throwout bearing) is held back: This is the engaged condition of the clutch.

Depressing the clutch pedal causes the release bearing to advance and push on the tips of the tapering fingers of diaphragm spring. When this happens, the diaphragm spring acts like the release levers of a conventional clutch, pulling the pressure plate away from the flywheel, thereby interrupting the flow of drive from flywheel through clutch disc to transmission input shaft.

The clutch construction is simple, well balanced relative to rotating speed, durable and capable of withstanding high torsional load and, what is particularly noteworthy, does not require the adjustment of the kind involved in the conventional coil-pressure-spring release-lever type of clutch.

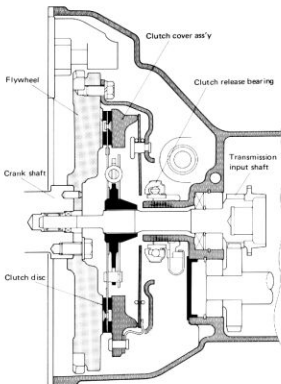

Fig: 11-1

11-2. Removal

Removal of the clutch presupposes that the engine has been dismantled according to the method outlined in the section for the engine. The clutch cover, disc and release bearing can be taken off only when the engine is off the machine.

Remove the 6 bolts securing the clutch cover to the flywheel, and take off the cover and clutch disc.

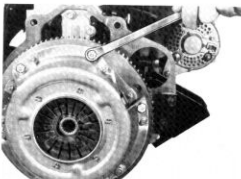

Fig. 11-2

With the clutch release bearing attached to the retainer, remove the retainer spring from the release shaft. The release bearing will come off as the spring is being removed.

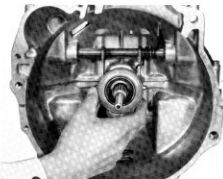

Fig. 11-3

11-3. Maintenance Services

Clutch disc facing surface condition

A burnt or glazed (glass-like surface) facing can be reconditioned by grinding it with No. 120 ~

200 sandpaper. If the surface is in bad condition beyond repair, replace the whole clutch disc assembly.

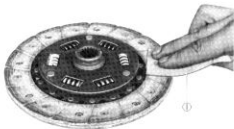

Fig. 11-4 ① Sandpaper

Clutch facing wear

Check the wear of the facing by measuring the depth of each rivet head depression, which is the distance between rivet head and facing surface. If the depressing is found to have reached the service limit at any of the holes, replace the clutch disc assembly.

Rivet head depression	Standard	Service limit
	1.2 mm (0.05 in.)	0.5 mm (0.02 in.)



Fig. 11-5

Backlash in disc serration fit

Check the backlash by turning the disc back and forth as mounted on the transmission input shaft. Replace the disc assembly if the backlash is noted to exceed the limit. Backlash here is a circular displacement as measured with a dial indicator.

A clutch disc exhibiting a large backlash will make an impact noise each time the clutch is engaged, and will prevent the clutch to engage smoothly.

Backlash in serration fit	Service limit
	0.5 mm (0.02 in.)

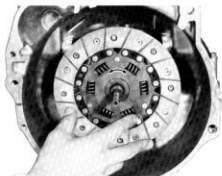

Fig. 11-6

Clutch cover

Inspect the clutch cover for evidence of the diaphragm spring rivets getting loose. If the rivets are loose or are tending to become loose, replace the cover assembly; such a cover makes a rattling noise when the clutch pedal is depressed.

Inspect the tips of the tapering fingers (to which the release bearing exerts a push to disengage the clutch) for wear. If the tips are worn excessively, replace the cover assembly.



Fig. 11-7 ① Spring wear; ② Rivet

Release bearing

Replace the release bearing if it sticks, rattles or makes abnormal noise when spun and turned by hand.



Fig. 11-8

Input shaft bearing and oil seal

Inspect the pilot bearing (by which the forward end of the input shaft is piloted in the crankshaft) and oil seal for evidence of malfunction at all times.

Abnormal noise coming from the clutch, when the clutch pedal is depressed to disengage the clutch, is often due to a defective pilot bearing.



Fig. 11-9 ③ Oil seal, ④ Bearing

Clutch pedal height

Bring the clutch pedal height to the same height as that of the brake pedal. This is to be accomplished by screwing in or out the adjusting bolt located near the pivoting point of the pedal arm.

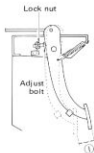

Fig. 11-10

Clutch pedal play

There are two places where adjustment is to be made for giving a proper amount of play to the clutch pedal. One is the clutch cable adjuster ②, above the engine mounting member; and the other is the inner cable adjusting nut at the distal end of the clutch release lever. The play is prescribed to be within the following range:

Clutch pedal play ①	15 ~ 25 mm (0.6 ~ 1.0 in.)
Clutch release arm play	2 ~ 4 mm (0.08 ~ 0.16 in.)



Fig. 11-11

NOTE:

In the right-hand steering machine, make the adjustment by means of the clutch cable adjuster in such a way that the inner cable will not extend more 5 mm (0.19 in.) from the adjusting nut. This is necessary for securing the prescribed amount of clearance between inner cable and steering gear box.



Fig. 11-12

11-4. Installation

The clutch is to be installed by reversing the removal procedure. Some important steps will be explained in detail.

Clutch disc and clutch cover

A special tool must be used to install the disc and cover, in order to align the two to the transmission input shaft. The tool is a sort of dummy; insert it into the bearing (pilot bearing) (as if it were the transmission input shaft). Then mount the disc and cover and, after bolting up the cover to the flywheel, draw off the mounting tool ④.

Clutch disc center guide (09923-36310)



Fig. 11-13

Input shaft bearing

There is a void between input shaft bearing and oil seal. Make this void 60% full with SUZUKI SUPER GREASE "A".



Fig. 11-14 ① Grease

Clutch release bearing retainer

Before installing the retainer, apply SUZUKI SUPER GREASE "A" to its inner surface.



Fig. 11-15 ② Grease

Clutch release arm

The release arm can be installed after the transmission has been mounted and set in place but there will be some difficulty of handling the arm with the transmission in place. The easier way is to install the arm before the transmission is installed; the method is as follows:

In the left-hand steering machine, match the punch marks on release arm and shaft. In the right-hand steering machine, locate the punch mark on release arm off the punch mark on release shaft by an amount equal to one serration, as shown. Secure the release arm good and hard to the shaft in that position.

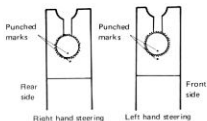

Fig. 11-16

12. GEARSHIFTING CONTROL

12-1. Description	160
12-2. Removal	161
12-3. Maintenance Services	161
12-4. Installation	162

12-1. Description

The movement of the gearshift lever is transmitted by the control shaft to the gearshift lever case, from which the three fork shafts are actuated selectively to shift the transmission.

1. Gear shifting lever knob
2. Gear shifting control lever
3. Boot
4. Housing
5. Seat
6. Spring
7. Dust seal
8. Guide plate
9. Gear shifting control shaft
10. Return spring

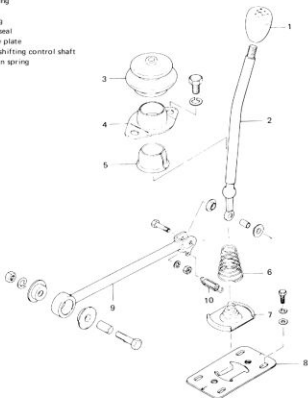

Fig. 12-1

12-2. Removal

To remove gearshift control lever, remove the four bolts, securing the guide plate, and two bolts, securing the lever housing. Remove the bolt connecting the lever to the control shaft, and pull the lever off.



Fig. 12-2

To remove gearshift control shaft, undo the connection between this shaft and the extension shaft on the transmission side by removing the bushed bolt and nut, and unhook the return spring from the other end, from which the gearshift lever has been disconnected.



Fig. 12-3

12-3. Maintenance Services

Gearshift lever adjustment

If it is hard to shift into "low" or "third," or if it has been reported that the gear slips out of mesh during normal cruising, displace the guide plate toward rear. Loosening the bolts securing the guide plate permits it to be so displaced.

If it is hard to shift into "second" or "top," or if "gear slipping" is complained of, displace the guide plate toward front.

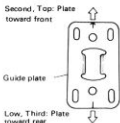

Fig. 12-4

If it is hard to shift in "reverse," displace the control lever housing toward the right. Loosening the bolts securing the housing permits it to be so displaced.

If the lever tends to shift into "top" when it is meant to go into "reverse," displace the control lever housing toward the left.

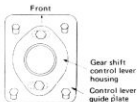

Fig. 12-5

Guide plate inspection

Replace the guide plate if its tongue parts "A" and "B" are excessively worn. A worn tongue "A" makes "reverse shifting" less articulate; a worn tongue "B" causes the shift lever in neutral to change its position.

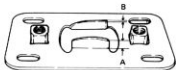

Fig. 12-6

12-4. Installation

1. Tightening torque

To be tightened to:	kg·m (lb·ft)
Joint nut, gearshift control rod	1.0 ~ 1.5 (7.5 ~ 10.5)
Front nut, gearshift control rod	0.6 ~ 1.0 (4.5 ~ 7.0)
Bolt, control lever guide plate	0.4 ~ 0.7 (3.0 ~ 5.0)
Bolt, control lever housing	2.0 ~ 2.5 (14.5 ~ 18.0)

2. Just before installing the two bushes for gearshift control shaft, apply grease to their outer surfaces. Also grease the inside surface of the control lever seat.



Fig. 12-7 ① Grease

3. Position the control lever guide to bring the arrow mark to the front side.

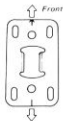

Fig. 12-8

4. Position and secure the gearshift control lever in such a way that, when it is moved into "top" position, there will be a clearance ② of 30 to 40 mm (1.18 to 1.57 in.) between it and transfer shift lever.



Fig. 12-9

13. TRANSMISSION

13-1. Description	164
13-2. Flow of Drive Through Transmission	165
13-3. Transmission Gear Ratio	167
13-4. Dismounting	167
13-5. Disassembly	167
13-6. Maintenance Services	170
13-7. Important Steps in Installation	173

13-1. Description

The transmission is full synchronized and provides four forward speeds and one reverse speed by means of two synchronizers and three shafts—input shaft, main shaft and countershaft. Input shaft and main shaft are in line, connected rotatably with a needle roller bearing in between. Gears on these shafts are in constant mesh with those of countershaft.

On the main shaft, low-speed synchronizer couples "low" driven gear or "second" driven gear to the main shaft. High-speed synchronizer couples "third" driven gear or input shaft to the main shaft. Reverse idler gear is for clash meshing, and meshes with the reverse idler mounted on the extended portion of the main shaft.

The transmission case is in two-piece construction, consisting of upper case and lower case. The upper case has the three-fork-shaft shifting mechanism built in it. The lower case supports the countershaft. Fitted to the case is an extension case, in which the gears for reverse drive are housed.

The forward section of the transmission case constitutes the housing for the clutch. As viewed from the clutch side, the clutch shaft and transmission input shaft are a single integral shafting extending into the transmission case. As mentioned above, this shaft is followed by the main shaft, which extends out from the other end of the case and is splined to the universal joint yoke.

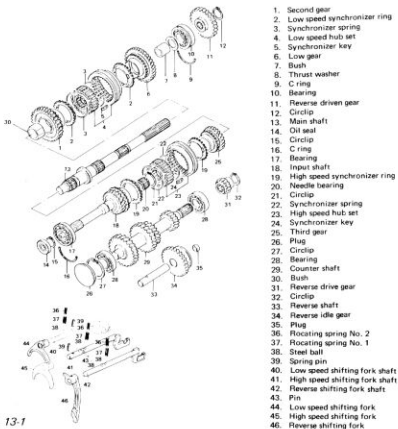

Fig. 13-1

13-2. Flow of Drive Through Transmission

How drive flows will be explained for each shift position:

Low speed drive

Low driven gear on the main shaft is free from this shaft and merely rotates around it, as driven from the low drive gear of the countershaft. Shifting the lever into "low" causes low-speed gear shifter fork to push low-speed synchronizer toward low driven gear and, through the dog teeth, mesh it with the gear, thus coupling the gear to the main shaft.

Under this condition, drive flows from input shaft to countershaft through one stage of speed reduction, and then from countershaft to main shaft, through another stage of speed reduction.

Second speed drive

Shifting the lever into "second" causes the same low-speed gear shifter fork to push low-speed synchronizer to the other direction, that is, toward second driven gear and mesh it with this gear, thereby coupling the gear to the main shaft. Under this condition, speed reduction takes place twice, as in the low speed drive described above, first between the gear of input shaft and that of countershaft and secondly between second drive gear (of countershaft) and second driven gear (on the main shaft).

Third speed drive

Shifting the lever into "third" actuates high-speed shifter fork to engage high-speed synchronizer with third driven gear on the main shaft. This gear, like low and second driven gears, is free on the shaft and merely spins as driven by third drive gear of countershaft when the gearshift lever is any other position. Just as in the case of low and second speed drives, drive flows from countershaft to main shaft through third drive and driven gears and high-speed synchronizer.

Top speed drive

Shifting the lever into "top" actuates the same high-speed shifter fork to engage high-speed synchronizer with the input shaft gear through dog teeth, thereby coupling input shaft direct with mainshaft. No speed reduction is involved in this flow of drive: engine crankshaft drives main shaft through input shaft.

Reverse drive

Shifting the lever into "reverse" actuates reverse gear shifter fork to mesh the reverse idle gear into the reverse gear on the main shaft. This is a "clash" meshing action, by which the idler gear comes into between the reverse drive gear of countershaft and the gear on the main shaft.

Drive is from input shaft to countershaft and then to main shaft through reverse idler gear. Two stages of speed reduction and reversal of rotary direction are involved in this drive.

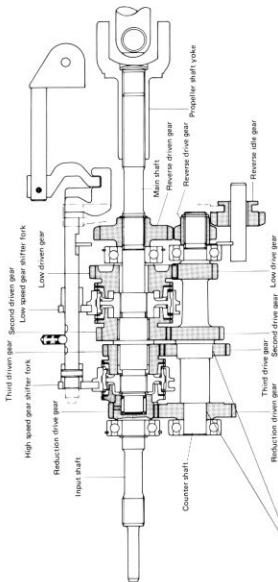

NOTE:
 If the gears are removed from the counter shaft, apply SUZUKI LOCK SUPER "103K" (99000-32030) to the inner surface of the gears and the outer surface of the shaft before reassembling.

Fig. 13-2

13-3. Transmission Gear Ratio

Primary gear ratio		34/19				
Primary speed ratio		1.789				
Shift position		Low	Second	Third	Top	Reverse
Secondary ratios	Gear ratio	30/14	29/22	25/29		27/12
	Speed ratio	2.143	1.318	0.862		2.250
Overall speed reduction ratio		3.835	2.359	1.543	1.000	4.026

13-4. Dismounting

- Take down the engine according to the dismounting procedure described in the section on the engine.
- Remove the drain plug to drain out the oil in the transmission.
- Remove the link bolt connecting gearshift lever shaft and control lever shaft.
- Disconnect the electrical lead from back-up light switch.
- Remove the two transmission mounting nuts, and remove it by carrying it toward the engine side.

13-5. Disassembly

Separating the upper case from the lower case.

Remove clutch release bearing from transmission input shaft.

Remove the bolts securing gearshifting case and take off the case from the transmission case.

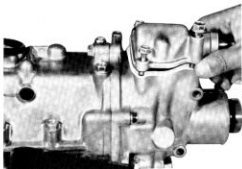

Fig. 13-3

Remove the bolts securing the extension case to the transmission case, and detach the extension case and mounting bracket.

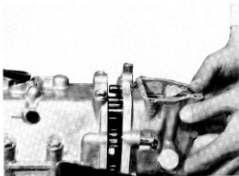

Fig. 13-4

Remove the bolts fastening the upper and lower cases together, separate the two, and take out the main shaft assembly. A steel bar, similar in shape to screwdriver, may have to be used to pry the two cases apart, as shown. In such a case, do not stick the bar too far into between the two mating faces or the faces may become damaged.

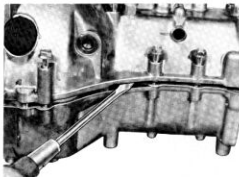

Fig. 13-5

Removing the countershaft

Remove the 2 bolts securing reverse gear shaft stopper plate, and take off the stopper plate and reverse gear shaft.

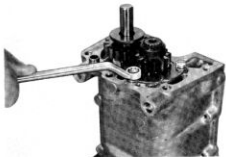

Fig. 13-6

Remove the circlip retaining the reverse gear on countershaft, using the circlip remover (A), and slide the reverse gear off countershaft.

Circlip remover (09900-06107)



Fig. 13-7

Remove the rubber plug on countershaft. Remove the circlip retaining the countershaft bearing, as shown.



Fig. 13-8

Pull off countershaft to the low gear side, remove the bearing, and take the countershaft assembly out of the case. Two special tools must be used for this removal:

Bearing installer (B) (09922-55130)

Bearing puller (C) (09913-60910)

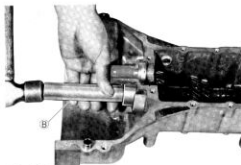

Fig. 13-9

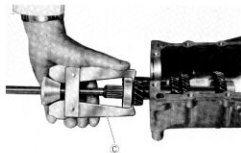

Fig. 13-9-1

Removing the main shaft and input shaft

Take out the input shaft by hand, taking care not to let the high-speed synchronizer rings drop.



Fig. 13-10

Remove the circlip retaining the hub of high-speed synchronizer sleeve, and slide off the sleeve hub and third driven gear from main shaft. A special tool (A) must be used in removing the circlip:

Circlip remover (A) (09900-06107)

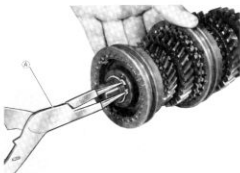

Fig. 13-11

Remove the circlip retaining the reverse gear on main shaft. Remove this gear and main shaft bearing. Be sure to use the circlip remover.



Fig. 13-12

From main shaft, take off the low driven gear, low-speed synchronizer sleeve hub and second driven gear. Be sure not to allow the synchronizer rings to drop down when the sleeve hub is coming off.



Fig. 13-13

Removing the shifter fork shafts and forks

Before starting the removal work, make sure that all the shifter fork shafts in place are in neutral position. First, remove the stopper plate for shifter fork shafts by removing the two bolts securing this plate.

It is important that the three shifter fork shafts be kept in neutral position at this time in order to make sure that the interlock balls between two adjacent shafts are seated fully in the dents of respective shafts. If any of these interlock balls is off the dent, some of the fork shafts will refuse to come out when pulled.

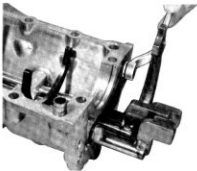

Fig. 13-14

Using the spring pin remover (special tool), draw out the spring pin on reverse gear shifter fork, and pull out the shifter fork shaft. As this shaft comes out, the locating ball and spring will jump out of the hole; do not let them fly away.

Spring pin remover (A) (09922-85811)

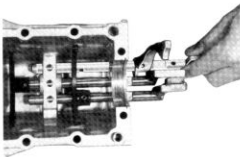

Fig. 13-15

Move the high-speed shifter fork shaft into the position for "third." This will allow the spring pin to shift into the dent provided in the case. Using the same special tool, mentioned above, draw out the spring pin and pull out the fork shaft. As in the case of above, be careful not to let the steel ball and spring fly away.

Having thus far removed the reverse gear shifter fork shaft and high-speed shifter fork shaft, you are now to remove the low-speed shifter fork shaft, as follows: Move this fork shaft into the position for "second," so that the spring pin will shift into the dent provided in the case; draw out the spring pin by using the spring pin remover, mentioned above; and remove the shaft by pulling it out.

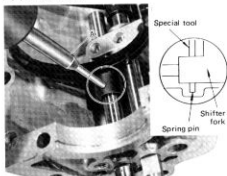

Fig. 13-16

13-6. Maintenance Services

Reverse gears and idle gear

Inspect the chamfered edges of gear teeth of the three gears—driving and driven gears (of main shaft and countershaft) and idle gear. If the edges are worn badly, replace the gears. Abnormal noise or gear slipping in reverse drive is often due to worn tooth edges of these gears.

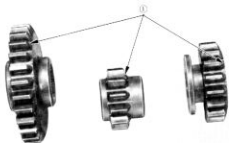

Fig. 13-17 ① Chamfered

Countershaft and its bearings

If any of the countershaft gears is found with chipped or broken teeth, replace the countershaft. Check each bearing by spinning its outer race by hand to "feel" the smoothness of rotation. Replace the bearing if noted to exhibit sticking, resistance or abnormal noise when spun or rotated by hand.

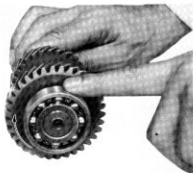

Fig. 13-18

Input shaft

Referring to Fig. 13-19, inspect the cone ① and toothed ring ② for wear and damage.

Inspect the gear teeth ③ and splines ④ for wear and damage.

If any part of the input shaft inspected as above is found excessively worn or badly damaged, replace the shaft.

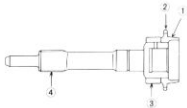

Fig. 13-19

Combination of gear and synchronizer ring

Fit the ring to the cone of the gear (input gear, or "third," "second" or "low" gear), and measure the clearance between the two at the peripheral teeth, as shown in Fig. 13-20. If the clearance is noted to have reached or exceeded the service limit, replacement is necessary.

Clearance between gear and ring	Standard 0.8 ~ 1.2 mm (0.03 ~ 0.05 in.)	Service limit 0.5 mm (0.02 in.)
---------------------------------	---	---------------------------------------



Fig. 13-20

Inspect the external cone (of the gear) and internal cone (of the ring) for abnormal wear. Be sure that the contact patterns on these surfaces indicate uniform full-face contact, and that the surfaces are free from any wavy wear. A badly worn member must be replaced.

Proper synchronizing action on gear shifting can be expected when the ring-to-gear clearance (Fig. 13-20) and the condition of cone surfaces, among other things, are satisfactory.



Fig. 13-21 ⑤ Checking contacting surface

Chamfered tooth ends of ring (external teeth) and sleeve (internal teeth)

Synchronizer ring and hub have three slots each, in which the keys are carried as backed by expanding springs, so that the hub and its two rings, one on each end, are capable of running together. Since the sleeve is engaged by its internal teeth with the hub, as if the two were splined together, the sleeve too runs with the hub and rings.

In meshing action, the sleeve is pushed (by the shifter fork) to one side, so that it slides axially on the hub, pushing the ring toward the cone surface of the gear. This push is transmitted by the three keys, which are lightly gripped by the sleeve.

By the friction between the gear cone and the ring cone (internal), the ring begins to rotate but is opposed by the hub because of the keys. In other words, the ring is at this time twisted, while the sleeve is advancing further to push the ring fully against the gear cone. Since the ring is unable to slide along any further, the

sleeve lets go of the keys and rides over to the ring. At this moment, the initial contact between the chamfered ends of teeth of the ring and those of internal teeth of the sleeve occurs. This contact is such that the internal teeth of the sleeve align themselves to those of the ring. When the sleeve advances and slides into the ring, the ring will be rotating nearly with the speed of the gear, so that the sleeve is enabled smoothly to slide over into the clutch teeth of the gear.

The initial contactor mesh between sleeve and ring is determined by the widths of key and slot or, to say the same thing, the key clearance in the slot, and is prescribed to extend at least a third (1/3) of the chamfer.

With the synchronizer properly assembled on the shaft, push in and twist each synchronizer to see if the one-third mesh occurs or not; if not, it means that the overall wear (which is the sum of the wears of slots, keys and chamfered tooth ends) is excessive and, in such a case, the entire synchronizer assembly must be replaced.

Mesh of chamfered tooth ends of synchronizer ring and hub	Contact extending about 1/3 of chamfered face from apex
---	---

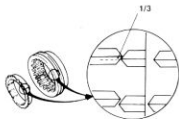

Fig. 13-22

Synchronizer rings

Inspect each synchronizer ring for wear of its key slots by measuring the width of each slot. If the width reading exceeds the limit, replace the ring.

Key slot width of synchronizer ring	Standard	Service limit
	9.6 mm (0.38 in.)	9.9 mm (0.39 in.)



Fig. 13-23

Fork shaft locating springs

Two kinds of locating spring are used to arrest the three shifter fork shafts. If "gears slipping out of mesh" has been complained, check these springs for strength by measuring their free lengths, and replace them if their free lengths are less than the service limits.

Spring No.	Standard	Service limit
Free length of No. 1	19.5 mm (0.767 in.)	17.0 mm (0.669 in.)
Free length of No. 2	17.5 mm (0.689 in.)	16.0 mm (0.630 in.)

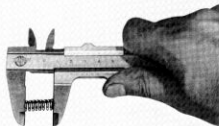

Fig. 13-24

Extension case bush

Check the bush press-fitted into the extension case for wear by measuring the radial clearance between bush bore and sliding yoke. If the sliding yoke is capable of rattling in the bush because of advanced wear it will cause the propeller shaft to rattle. For this reason, an extension case found to allow its sliding yoke to rattle in excess of the service limit must be replaced; replacement of the bush alone is not permissible.

Rattle of sliding yoke in extension case bush	Standard	Service limit
	0.02 ~ 0.06 mm (0.0008 ~ 0.0024 in.)	0.1 mm (0.004 in.)

13-7. Important Steps in Installation

Tightening torque

To be tightened to:	kg-m (lb-ft)
Transmission case bolt	1.5 ~ 2.0 (11.0 ~ 14.5)
Oil drain plug and level plug	3.0 ~ 5.0 (22.0 ~ 36.0)
Extension case bolt	1.5 ~ 2.0 (11.0 ~ 14.5)
Rear mounting bolt	1.5 ~ 2.0 (11.0 ~ 14.5)
Gearshift lever case bolt (8 mm)	0.9 ~ 1.2 (7.0 ~ 8.5)
Gearshift lever case bolt (6 mm)	0.4 ~ 0.6 (3.0 ~ 4.0)
Bolt on stopper plate for shifter fork shafts	1.5 ~ 2.0 (11.0 ~ 14.5)

Input shaft and main shaft

When assembling the two synchronizers on main shaft, be sure to position the hub of each correctly. As shown in Fig. 13-25, the hub has an inner boss, whose end face is almost flush with the end face of the toothed outer part. Make sure to bring that end face to the clutch side.

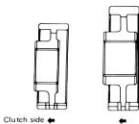

Fig. 13-25

Care must be exercised in positioning the sleeve of each synchronizer. Be sure to bring the groove for admitting the fork to the clutch side.

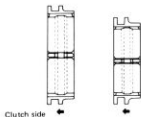

Fig. 13-26

After putting on each synchronizer, be sure that the three keys mounted on the hub fit snugly into the slots provided in the ring.



Fig. 13-27

Shifter forks and shafts

When feeding each shifter fork onto its shaft, be sure to bring the boss (in which the hole for admitting the spring pin is provided) to the extension case side.

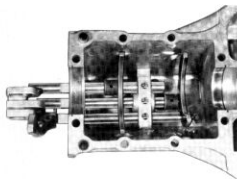

Fig. 13-28

Two kinds of coil spring are used to push down on the locating steel balls. One is larger in coil diameter, and is designated as No. 1 spring; the smaller one is designated as No. 2 spring. Each locating steel ball is backed by two springs, No. 1 and No. 2. Thus, there are a total of six springs, that is, three No. 1's and three No. 2's, for the three fork shafts, reverse, high-speed and low-speed, as shown in Fig. 13-29. At the time of installing the balls and springs, be sure to discriminate the two kinds.

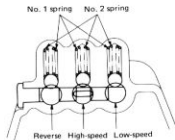

Fig. 13-29

The shifter fork shafts are to be installed sequentially. First to be put in place is low-speed shaft, followed by high-speed shaft and then reverse shaft. The sequence is indicated in the ascending order of numbers in Fig. 13-30.

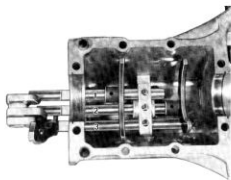

Fig. 13-30

The hole for installing the interlock steel balls is provided in the side wall, next to the reverse shifter fork shaft, of the transmission case. Be sure to feed in one ball after another, positioning each ball between two adjacent shafts, as shown in Fig. 13-31.

NOTE:

Be sure to put in the pin for preventing two shafts from getting shifted at the same time. This pin goes into the hole provided in the high-speed shaft.

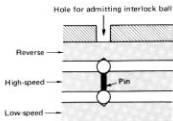

Fig. 13-31

Reverse gears and idle gear

The two reverse gears have their teeth chamfered on one end, and the reverse idle gear is similarly chamfered. When mounting the reverse gears on main shaft and countershaft, respectively, be sure to bring the chamfered end to the outboard side. The chamfered end of the idle gear, however, must face inwardly, as shown in Fig. 13-32.

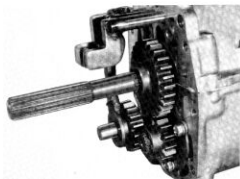

Fig. 13-32

Input shaft and main shaft installation

Before installing the input and main shaft assembly on the lower case, be sure fit the "C" rings (1) and dowel pins (2) into the case.

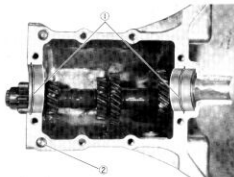

Fig. 13-33

Putting together upper and lower cases

Clean the joint faces, removing any foreign matters adhering to these faces, and then apply the liquid sealing compound (SUZUKI Bond No. 4, 99000-31030) to the point faces, coating each face uniformly with the compound and, a few minutes after this application, match the two cases together.

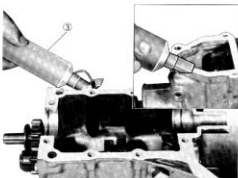

Fig. 13-34 ③ SUZUKI bond No. 4

When bringing the two cases into match as shown in Fig. 13-35, be sure to guide each shifter fork into the groove of its synchronizer sleeve. After putting the upper case on the lower case, tighten the joint bolts uniformly and sequentially so as to equalize the joint pressure all around.

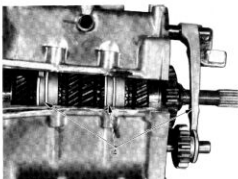

Fig. 13-35 ④ Shifting forks

Extension case oil seal

The oil seal (5) used in this case is of helix type as shown in Fig. 13-36. When installing this seal, be sure to position it so that its helical part comes on the inner side.

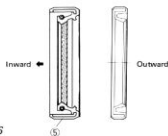

Fig. 13-36

NOTE:

When installing the oil seal of the following type, be sure to position it so that its spring

① part comes on the inner side.

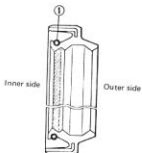

Fig. 13-36-1

Transmission oil

The oil capacity of the transmission and the oil specification are as follows:

Oil capacity	1.0 litres (2.12/1.76 US/Imp.pt.)
Oil specification	Gear oil, SAE 75W 80~85



Fig. 13-37 ① Oil filler plug



Fig. 13-38 ② Oil drain plug

14. TRANSFER GEAR BOX

14-1. Description	178
14-2. Selective Flows of Transfer Drive	179
14-3. Gear Ratio Data	180
14-4. Removal	180
14-5. Disassembly	181
14-6. Maintenance Services	184
14-7. Important Steps in Installation	185

14-1. Description

The transfer gear box is an auxiliary transmission for on-off control of two-speed drive transmitted to both front and rear axles concurrently and provides additional speed reductions, HIGH and LOW, for any selection of main transmission gears.

The functions of this auxiliary transmission are mainly two—selection between four-wheel drive (front and rear axles) and two-wheel drive (rear axle) and between HIGH and LOW for four-wheel drive. Three propeller shafts are associated with the gear box.

These functions are accomplished by means of four shafts arranged in three-axis configuration and two sliding clutches. The selection is effected by actuating these clutches from a single control lever located beside the driver's seat and in the floor tunnel section. The gear box is mounted on a chassis cross member.

1. Oil seal
2. Retainer
3. Gasket
4. Bearing
5. Transfer input shaft
6. Bearing
7. Circlip
8. Bearing plug
9. Stopper pin
10. Transfer counter gear shaft
11. Bush
12. Thrust washer
13. Bearing
14. Spacer
15. Transfer counter gear
16. Plug
17. Circlip
18. Bearing
19. Transfer output front shaft
20. Rear shaft hub set
21. Circlip
22. Circlip
23. Bearing
24. Retainer
25. Bearing
26. Transfer output rear shaft
27. Bush
28. Output shaft low gear
29. Thrust washer
30. Bush
31. Output shaft high gear
32. Bearing
33. Speedometer drive gear
34. Speedometer driven gear
35. Bearing
36. O ring
37. Spacer
38. Oil seal
39. Thrust washer
40. Gasket
41. Speedometer gear case
42. Oil seal
43. Driver gear pin

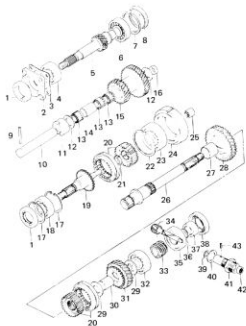

Fig. 14-1

Transfer input shaft is connected to the output shaft of the main transmission and its gear as in constant mesh with one (big gear) of the two of transfer countershaft. The big gear is in constant mesh with "high" gear, which is rotatably mounted on transfer output rear shaft. The other gear (small gear) of countershaft is in constant mesh with "low" gear rotatably mounted on the same rear shaft.

Rear clutch, by its sleeve, is capable of coupling "low" or "high" gear to the rear shaft. The front end of this shaft is rotatably connected to transfer output front shaft, and carries front clutch capable of rigidly coupling rear shaft to front shaft by its sleeve engaging with the toothed clutch ring integral with front shaft.

The engaging and disengaging actions of the sleeve, actuated by a shifter fork, of each clutch are similar to the sleeve of the synchronizer used in the main transmission.

The major working members of the transfer gear box having thus been identified in reference to Fig. 14-1, the selective flows of drive will be described.

14-2. Selective Flows of Transfer Drive

2-wheel drive (Rear-wheel drive)

Rear shifter fork pushes rear clutch sleeve into "high" gear, thus coupling the gear to output rear shaft.

Drive flows from input shaft to output rear shaft through big gear, "high" gear and rear clutch.

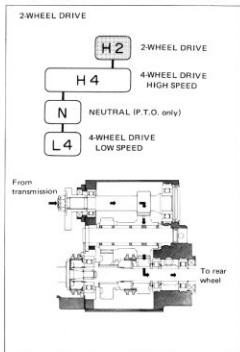

Fig. 14-2

4-wheel drive HIGH (All-wheel drive on HIGH)

Under the conditions of rear-wheel drive, described above, front shifter fork pushes the sleeve of front clutch onto the toothed clutch ring, thus coupling output rear shaft to output front shaft. Front shaft and rear shaft run together on HIGH.

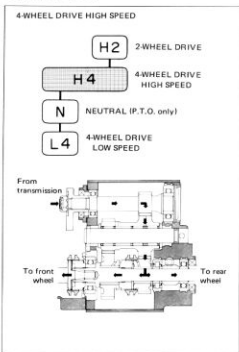

Fig. 14-3

4-wheel drive LOW (All-wheel drive on LOW)

Front shifter fork actuates front clutch to couple rear shaft to front shaft; and rear shifter fork actuates rear clutch to couple "low" gear to rear shaft. Front shaft and rear shaft run together on LOW.

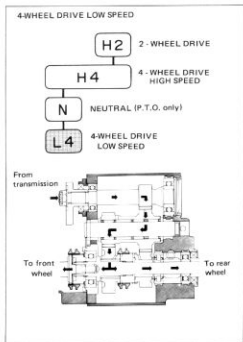

Fig. 14-4

14-3. Gear Ratio Data

Model LJ80 & LJ80V

Shift position	Rear-wheel drive	All-wheel drive high	All-wheel drive low	
Primary gear ratio (Reduction ratio)	27/16 (1.688)			
Secondary ratios	Gear	25/27	25/27	32/21
	Reduction	0.926	0.926	1.524
Overall transfer reduction ratio	1.563	1.563	2.571	

14-4. Removal

- 1) Remove the knob from transfer gear control lever. Turning the knob makes it come off the lever.
- 2) Remove the seven screws securing the cover on transfer servicing hole and take the cover off.
- 3) Apply the parking brake. Remove the securing bolts from each universal-joint flange connection to sever the three propeller shafts from the transfer gear box.
- 4) Disconnect the parking brake wire at parking brake lever.
- 5) Disconnect speedometer drive cable from the transfer gear box.
- 6) Remove the four mounting bolts securing the gear box to the chassis cross member, and take down the gear box.
- 7) Drain out oil from the gear box taken down by loosening its drain plug.

14-5. Disassembly

Universal-joint yoke flanges

There are two flanges to be removed: one from the input shaft and one from the output front shaft. Lock the flange so that it will not turn, and loosen and remove the nut holding the flange to the shaft. Draw off the flange.

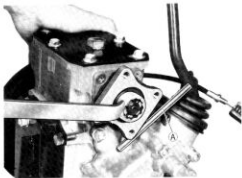

Fig. 14-5 (A) Rod

Center brake

Utilize the differential preload checking tool on the center brake drum so that the drum will not turn. Loosen and remove the nut securing the drum.

Differential preload checking tool (B) (09922-75220)

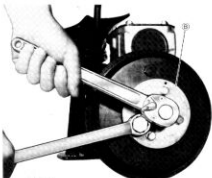

Fig. 14-6

Remove the brake shoes. Remove the 4 bolts securing the backing plate, and take out the backing plate assembly.

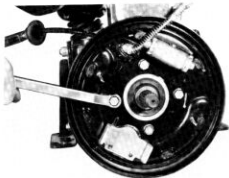

Fig. 14-7

Speedometer driven gear

Remove the speedometer driven gear, as shown in Fig. 14-8.

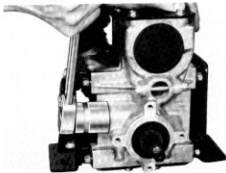

Fig. 14-8

Transfer gear control lever

Twist the control lever guide counterclockwise while pushing it down; this will permit the lever to be removed from the gear box.

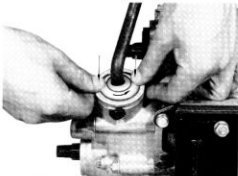

Fig. 14-9

Upper transfer cover

Remove the bolts securing the upper transfer cover, and take off the cover.

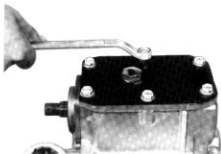

Fig. 14-10

Transfer front case

Remove the nuts fastening down the transfer front case; tap around on the edge of the case with a mallet to shake the case loose. Remove the front case complete with the output front shaft. Drive on the front shaft with the mallet to force it off the front case.

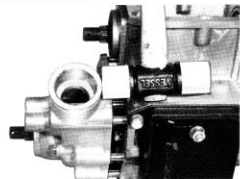

Fig. 14-11

Transfer input shaft

Remove the 4 screws securing the retainer of input shaft bearing, and take out the retainer.

Shock driver **A** (09900-09002)



Fig. 14-12

Draw out the input shaft by using the special tool, as shown in Fig. 14-13.

Transfer input shaft puller **B** (09922-65122)

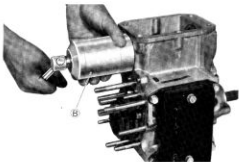

Fig. 14-13

Transfer countershaft

Using the spring remover (special tool), remove the spring pins locking front clutch shifter fork and lever stopper. Remove the shifter fork and stopper from the shifter fork shaft.

Spring remover **C** (09922-85811)

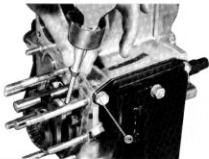

Fig. 14-14

Remove the front clutch sleeve from clutch hub. Using the circlip remover (special tool), remove the circlip retaining the front clutch hub in place, and slide the clutch hub off output front shaft.

Circlip remover (A) (09900-06107)

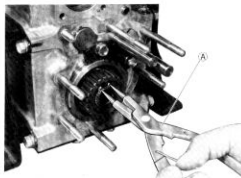

Fig. 14-15

Remove the two bolts securing the stopper plate for gear shifter fork shaft, and displace the stopper plate off the stopper of countershaft.

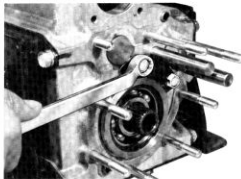

Fig. 14-16

Take a firm grip on the end of countershaft, using a pair of pliers, 2nd pull the countershaft out. Take out the counter gears, three needle roller bearings, spacer and two thrust washers from inside the case.

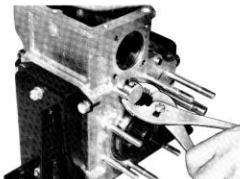

Fig. 14-17

Shifter fork shafts

The plug keeping the shifter shaft locating (arresting) balls and springs in place is on the left-hand side wall of the case. Remove this plug, and take out the steel balls and springs.

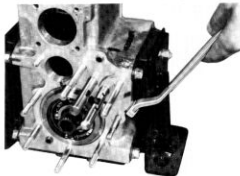

Fig. 14-18

Push the rear clutch shifter shaft into HIGH position (1), and pull out the front clutch shifter shaft.

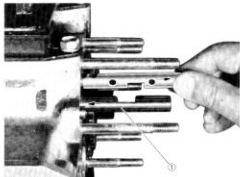

Fig. 14-19

Using the spring remover (special tool), drive out the spring pin locking the rear clutch shifter fork; and pull out the shaft of this fork; do not rotate the shaft or the steel ball may settle into the dent to prevent it from coming out.

Spring remover (A) (09922-85811)

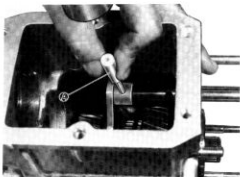

Fig. 14-20

Output rear shaft

Using a mallet, drive on the center-brake side end of the output rear shaft to force it out of the case. The shaft will come out complete with the output shaft bearings, retainers and clutch.

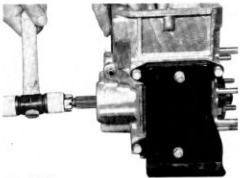

Fig. 14-21

14-6. Maintenance Services

Gear teeth

Inspect the gear teeth ①, the internal teeth of rear clutch sleeve ② and the clutch teeth of the gear ③ for wear, cracking, chipping and the like malcondition. Replace the gear or sleeve as necessary.



Fig. 14-22

Locating spring

Check each shifter fork shaft locating spring for strength by measuring its free length. If the length is noted to be less than the service limit, replace it.

Free length of locating spring	Standard		Service limit	
	No. 1	19.5 mm (0.767 in.)	17.0 mm (0.669 in.)	16.0 mm (0.629 in.)
	No. 2	18.5 mm (0.728 in.)	16.0 mm (0.629 in.)	



Fig. 14-23

Parking brake

The parking brake is identical in all respects to the rear wheel brake except for the shoe actuating member, which is a hydraulic cylinder (wheel cylinder) in the rear wheel brake.

Drum-to-shoe clearance is to be adjusted in the same way, that is, by rotating the adjusting screw with a screwdriver inserted through a hole provided in the drum.



Fig. 14-24 ① Brake adjusting hole

The clearance is to be set as follows:

For each shoe, turn its adjusting screw to reduce the clearance to zero, that is, make the shoe lining bear against the drum. From that position of the screw, move it back:

3 to 7 notches	For leading shoe
4 to 8 notches	For trailing shoe

After setting the clearance as above, rotate the drum by hand to be sure the shoes are not dragging on the drum. The object of this adjustment is to provide the smallest possible clearance that is free from any signs of dragging.

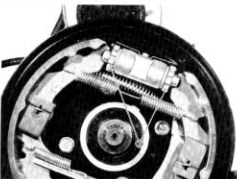

Fig. 14-25 ② Brake adjusting nut

14-7. Important Steps in Installation

Tightening torque

To be tightened to:	kg-m	lb-ft
Bolt, upper-case cover	0.9 ~ 1.2	7.0 ~ 8.5
Bolt, lower-case cover	0.6 ~ 1.0	4.5 ~ 7.0
Bolt, transfer front case	1.5 ~ 2.0	11.0 ~ 14.5
Bolt, stopper plate, shifter fork shaft	0.9 ~ 1.2	7.0 ~ 8.5
Oil filler plug and drain plug	3.0 ~ 5.0	22.0 ~ 36.0
Universal joint flange nut	7.0 ~ 10.0	51.0 ~ 72.0
Transfer case mounting nut	1.5 ~ 2.0	11.0 ~ 14.5
Bolt, cross joint flange	1.5 ~ 2.5	11.0 ~ 18.0
Transfer case mounting bolt	1.0 ~ 1.5	7.5 ~ 10.5

Clutch sleeve hubs and gears

Be sure to install clutch sleeve hubs and gears on the two transfer shafts (output shaft, rear, and counter gear shaft) correctly as shown in Fig. 14-26. Refer to this figure for the correct positioning of these parts.

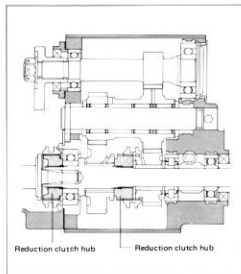

Fig. 14-26

Output rear shaft

When installing the output rear shaft in the case, be sure to position its bearing retainer and the countershaft bush in such a way that the grooves of the retainer and bush will line up, as shown. Use of a special tool is involved in this step.

Bearing installer (A) (09913-85210)

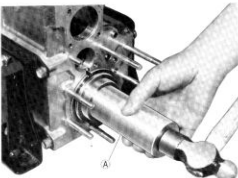

Fig. 14-27

Locating springs and balls for shifter fork shafts

Care must be taken to ensure that these springs and balls take their positions correctly so that they will function properly in arresting the shafts and in preventing the shaft from slipping out of its "arrested" position to result in accidental clutch disengagement or in clutch "grating." After putting in the springs and balls, test the shafts for arresting action by moving them by hand.



Fig. 14-28

Shifter fork shafts and forks

Each shaft is to be installed in this sequence: Secure the shifter fork to the rear clutch shifter fork shaft in place, with the fork set astride in the groove of the clutch sleeve; move the clutch sleeve into mesh with "high" gear; and then insert the front clutch shifter fork shaft. This sequence is mandatory: if the rear clutch should be left in neutral position when the front clutch shifter fork shaft is inserted, the locating balls already in place would prevent this shaft from getting installed.

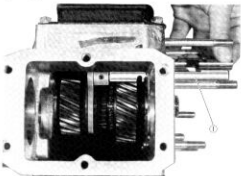

Fig. 14-29 ① Push shaft into HIGH position

Make sure that the grip boss of each shifter fork comes on the inner side as shown. This means that the boss (into which a spring pin is driven in to lock the fork to the shaft) of the rear clutch shifter fork points to "low" gear side, and that of the front clutch shifter fork points to "high" gear side.

Of the two shifter forks, the one with a longer boss is for rear clutch, the other is for front clutch.

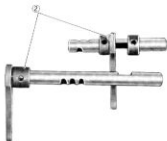

Fig. 14-30 ② Make sure the boss is on the inboard side

Counter gear needle bearings

The counter gear runs on three needle roller bearings. Two of these bearings support the large end, and the remaining one the small end, with a spacer in between. When installing the counter gear, be sure to locate these bearings as shown. With the bearings located in any other way, the counter gear might fail in service.

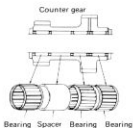

Fig. 14-31

Counter gear assembly

The procedure of assembling and installing the countershaft is slightly complicated. First, fit the three needle bearings and spacers into the gear cluster (small gear and big gear), oil the bearings in the bore, and attach the two thrust washers, one on each end of the gear cluster. Use grease to hold the washers to the end faces, as shown. Lower the gear cluster in suspended condition into the case, holding the gear cluster level and steady, as shown in Fig. 14-32, and aligning its bore to the shaft holes provided in the walls of the case. Then insert the countershaft through the case and gear cluster.



Fig. 14-32 ① Grease

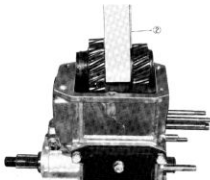

Fig. 14-33 ② Belt or strip

Counter gear stopper pin

Before installing the stopper plate, which is primarily for shifter fork shafts, make sure that the stopper pin for countershaft has been properly set in place. Tighten the securing bolts on stopper plate while keeping the plate pushed toward the shifter fork shafts, so that the stopper plate will be fully effective in its secured condition.

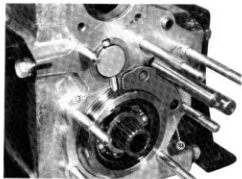

Fig. 14-34 ③ Pin ④ Stopper plate

Transfer case covers

The securing bolts on the upper and lower covers of the case are to be tightened sequentially and in steps so that the joint pressure will be distributed uniformly. Move the wrench from bolt to bolt across the cover, tighten each bolt just a little at a time.

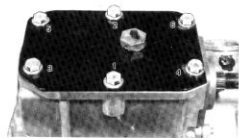

Fig. 14-35

Lubricating oil for transfer gear box

The gear box takes in 0.9 litre of oil (1.9/1.6 US/Imp. pt.). For the oil, use high-grade gear oil of SAE 90.

Transfer gear box oil capacity and specification
0.9 litre (1.9/1.6 US/Imp. pt.) SAE 90 gear oil

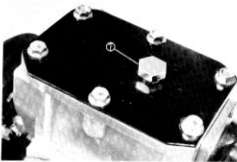

Fig. 14-36 ① Oil filler plug

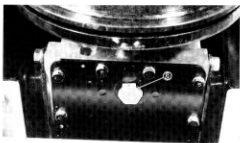

Fig. 14-37 ⑧ Oil drain plug

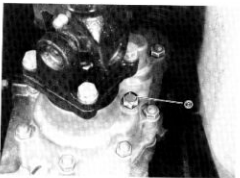

Fig. 14-38 ⑨ Oil level screw

15. PROPELLER SHAFTS

15-1. Description	190
15-2. Removal	191
15-3. Maintenance Services	191
15-4. Installation	192

15-1. Description

The two models, LJ80 and LJ80V, covered in this manual are four-wheel drive machines and, as such, use three propeller shafts designated as No. 1, No. 2 and No. 3.

No. 1 propeller shaft transmits drive from the transmission to the transfer gear box. No. 2 shaft and No. 3 shaft extend from the transfer gear box, the former driving the front axle and the latter the rear axle. Each propeller shaft is terminated by universal joints to permit the shaft to accommodate the radial displacement of the driven member relative to the driving member; and each universal joint is connected to the driving or driven shaft through spline engagement, the internal splines being provided in the distal yoke of the joint, so that the propeller shaft permits the driven member to axially displace itself relative to the driving member. These two kinds of displacement are possible within certain limits, and are expected to occur between the transmission and the transfer gear box, between the transfer and the front axle and between the transfer and the rear axle.

The cross spider in each universal joint is fitted with four needle roller bearings.

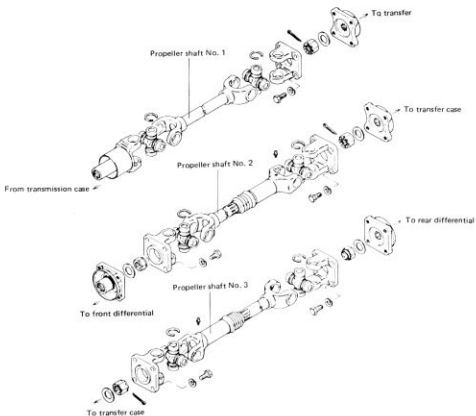

Fig. 15-1

- 2) Using the universal joint assembler (Special tool 09922-95210), push the spider bearing race out 3 - 4 mm (0.12 - 0.16 in.) from the shaft yoke race.



Fig. 15-6

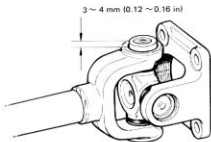

Fig. 15-7

- 3) Tapping the yoke with a hammer completely remove the bearing race.



Fig. 15-8

- 4) Take out the bearing race on the other side in the same way as 2) and 3).

- Disassembling on the flange yoke side
Push out the bearing race on the flange yoke side as described in 1) and 2), and then, holding the bearing race in a vice, tap the flange yoke and take out the race. (Refer to Fig. 15-9.)
Remove the bearing race on the opposite side in the same way.

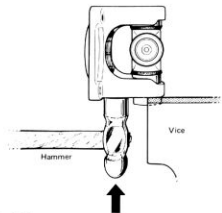

Fig. 15-9

NOTE:

- Take care not to lose the rollers in the spider bearing race when removing it.
- Fit the removed bearings temporarily in the spider so that they can be reinstalled in their original positions.

[Reassembly of universal joint ass'y]

NOTE:

- Make certain that the rollers inside the spider bearing race are all in place.
- Make certain that the charge the SUPER bearing race with SUZUKI SUPER GREASE C (99000-25030).



Fig. 15-10

CAUTION:

In reassembly, be sure to use new "C" rings, spider, and bearings. Reuse of "C" rings, spider, and bearings removed in disassembly is prohibited.

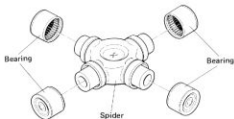

Fig. 15-11

- 1) Insert the bearing race into the yoke, tapping it with a hammer, until it is flush with the yoke face. When doing this, insert the spider into the bearing race to prevent the rollers in the bearing race from coming out.

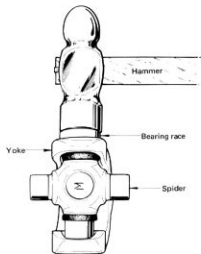

Fig. 15-12

- 2) Insert the other bearing race on the opposite side into the yoke, tapping with a hammer until it is flush with the yoke face.
- 3) Insert the bearing races on the flange yoke side in the same way as described in 1) and 2) above.

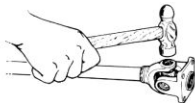

Fig. 15-13

- 4) Place a metal plate on the bearing races when tapping them in to avoid damaging the yoke.
- 5) Securely fit four C rings to the bearing races.

15-2. Removal

- 1) Lift the machine off the floor by jacking up the axles, and rest it on safety stands.
- 2) At each splined connection, remove the four bolts securing the yoke to its splined companion flange piece. This disconnects the propeller shaft, leaving the flange piece behind.

The transmission-side end of No. 1 shaft has no flange piece; this end is splined to the driving shaft inside the extension case. All you have to do there is to pull No. 1 shaft off the extension case.

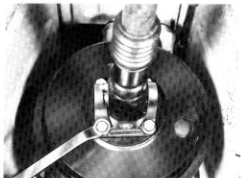

Fig. 15-2

15-3. Maintenance Services

Lubrication

The inside yoke of each universal joint has a grease nipple. At regular intervals stated in the recommended servicing schedule, pump in grease to relubricate the joint. Use chassis grease.



Fig. 15-3

Universal joint noise

If the universal joints are suspected of producing chattering or rattling noise, inspect them for wear. Check to see if the cross spider rattles in the yokes or if the splines are worn down.

The noise coming from universal joint can be easily distinguished from other noises because the rhythm of chattering or rattling is in step with cruising speed. The noise is pronounced particularly on standing start or in the coasting condition (when the braking effect of the engine is showing in the drive line).



Fig. 15-4

[Disassembly of universal joint ass'y]

When abnormal noise is generated while running, or when the spider bearing wears away, disassemble the universal joint and replace with a new one. The disassembly procedure is as follows:

- Disassembling on the propeller shaft yoke side
- 1) Using two plain screwdriver, remove 2 circlips.

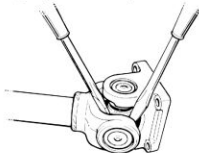

Fig. 15-5 Removing circlip

15-4. Installation

The installing procedure is reverse of the removal procedure. Be sure to adhere to the following instructions when installing the shafts:

- Flange tightening torque

Be sure to tighten the four bolts to the following torque value when securing the companion flange to the yoke at each end of the propeller shaft:

Tightening torque for universal joint flange bolts	1.5 ~ 2.5 kg-m (11.0 ~ 18.0 lb-ft)
--	---------------------------------------

- Grease the splines liberally, filling the grooves with grease.

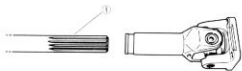

Fig. 15-14 ① Grease (chassis grease)

- Match marks are provided on the slip-on spline connections. Inserting the splined end into the splined bore without regard to the match marks can be a possible cause of noise or vibration of the propeller shaft. Be sure to index the marks.

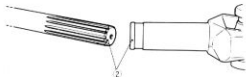

Fig. 15-15 ② Match marks

- The joint sheath rubber has a large diameter in one end and a small diameter in the other. Be sure to fit the sheath rubber with its large-diameter end brought to the joint yoke side.

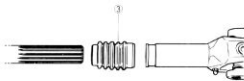

Fig. 15-16 ③ Joint sheath rubber

16. DIFFERENTIAL

16-1. Description	194
16-2. Removal	195
16-3. Disassembly.	197
16-4. Maintenance Services.	198
16-5. Reassembly Instructions	204

16-1. Description

The two axles, front and rear, are identical as far as the designs of pinion-and-gear drive and differential gearing are concerned. The major difference in this limited sense lies in the shape of the housing.

Each axle may be regarded as consisting, speaking roughly, of supporting parts (axle sleeves, differential housing and carrier case) and drive transmitting parts (bevel pinion and gear, differential gearing and live axle shafts). In the present section, only the bevel pinion and gear and differential gearing are taken up under the collective title of "differential."

The bevel gear drive is of hypoid design; pinion and gear have hypoid gear teeth. This means that the pinion is located slightly below the center of the bevel gear to permit the car body to be lowered in design, and that some wiping or sliding action occurs in tooth meshing between pinion and gear. Here lies the reason why use of hypoid gear oil is specified for the differential.

Four differential pinions are used in the differential case to qualify this gearing for heavy-duty "differential" drive. Thus, a total of 8 gears—a drive pinion, a crown gear, two side gears and four pinions—are inside the differential housing, all mounted on the differential carrier case bolted to the housing.

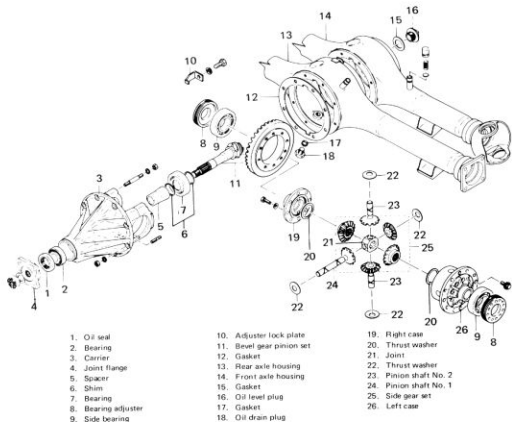

Fig. 16-1

16-2. Removal

Instructions and information given in this and subsequent sub-sections apply to both axles, front and rear, except where otherwise indicated:

1. Loosen, but do not remove, hub nuts all road wheels, and raise the machine off the floor by jacking.
Rest the machine steady on safety stands.
2. Drain out the oil in the differential housing by loosening the drain plug.
3. Remove the hub nuts and take the wheels, front and rear. Each wheel has five hub nuts.

For front differential

After taking down the front wheels, remove the nuts and brake drums. Draw out the brake drum using special tools.

Front drum remover (A) (09943-35511)

Sliding hammer (B) (09942-15510)



Fig. 16-2

Disconnect brake pipe from brake hose, above the kingpin. Have a small plug ready for use when disconnecting the pipe. As the pipe comes off the hose, insert the plug into the hose to prevent the brake fluid from leaking out.

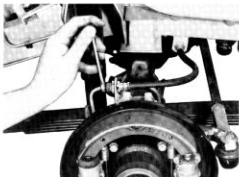

Fig. 16-3

Remove the four bolts securing the brake backing plate, and take off the plate complete with shoes, wheel cylinder and others.



Fig. 16-4

At each tie rod end, remove the nut and disconnect the end from steering knuckle. If the stud is tight in the hole of knuckle arm, put on the nut and lightly tap on the stud to shake it loose. The nut so put on serves to protect the threads.

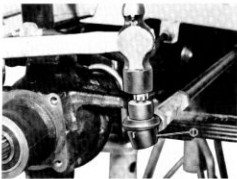

Fig. 16-5 ① Tie rod end

Remove the 8 bolts securing the oil seal cover. From the knuckle arm case, take off felt pad, oil seal and seal retainer. Remove the top and bottom kingpins from the case by removing the 4 bolts securing each pin.

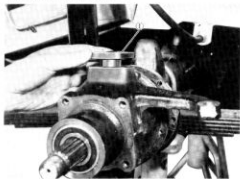

Fig. 16-6 ① Kingpin

Draw out the live axle shaft from the axle sleeve. The shaft at this time is complete with the steering knuckle and constant-velocity flexible joint.

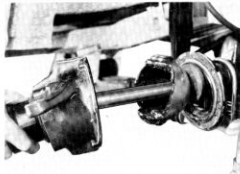

Fig. 16-7

At the differential housing, disconnect the propeller shaft by removing the bolts securing flange yoke to companion flange. Remove the 8 bolts holding fast the differential carrier case to the housing, and take down the carrier assembly.



Fig. 16-8

For rear differential

Remove the 4 bolts securing the outer-bearing retainer, and remove the retainer from the brake backing plate.

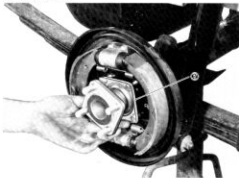

Fig. 16-9 ② Retainer

Using the special tools indicated below, draw out each live axle shaft.

Rear axle remover (A) (09922-66010)

Sliding hammer (B) (09942-15510)

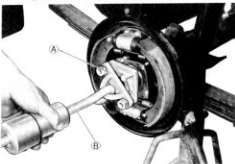

Fig. 16-10

Disconnect the propeller shaft as in the case of the front axle, and detach and take down the differential carrier case from the housing by removing the 8 bolts.



Fig. 16-11

16-3. Disassembly

Lock the flange immovable, and remove the nut from the end of the bevel pinion shank.



Fig. 16-12

Scribe marks on each cap bolted to the saddle portion of the carrier case and holding down the side bearing. The marks are to identify the cap. This means that there are right and left caps, so identified and so handled at the time of reassembly.



Fig. 16-13 ① Scribed match marks

At each side, loosen the bolts on bearing adjuster stopper, remove the nuts securing the bearing cap, and take off the cap. Lift the differential case assembly, complete with the bevel gear, off the carrier.



Fig. 16-14

Remove the 10 bolts securing the bevel gear to the differential case, and separate the gear from the case.



Fig. 16-15

There are 8 bolts fastening the two differential case halves together. Remove these bolts to sever the right-hand case half from the left-hand one, and take off the right-hand one.



Fig. 16-16

Remove the side gears, differential pinions as mounted on the spider, and thrust washers.

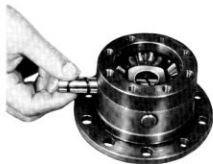

Fig. 16-17

Using the special tools indicated below, extract the side bearing from each differential case half.

Bearing puller (A) (09913-60910)
Side bearing removing jig (B) (09913-85230)



Fig. 16-18

16-4. Maintenance Services

Side gear backlash

To check this backlash, assemble the differential gearing and case, as shown in Fig. 16-19, fastening together the two case halves by tightening the securing bolts to the prescribed torque value. Use fuse stock to measure the backlash in the usual manner. By comparing the backlash reading, taken on the flattened fuse stock, against the standard backlash indicated below, increase or decrease the total thickness of thrust washers, which are located in two places, that is, on the inner side of each case half.

Side gear backlash specification or Side gear thrust play specification	0.05~0.10 mm (0.002~0.004 in) 0.15~0.3 mm (0.006~0.012 in)
Available thrust washer sizes (thickness)	0.8, 1.0 & 1.2 mm (0.03, 0.04 & 0.05 in)



Fig. 16-19

Determination of shim thickness for bevel pinion

The amount of shims to be used on the bevel pinion varies from one machine to another on account of a number of factors involved in machining and assembling. Thus, for each machine, the amount of shims necessary for locating the pinion in the correct position (for producing a proper backlash in the mesh between pinion and gear) must be determined anew at the time of reassembly.

In order to facilitate this determination, a two-piece dummy tool (special tool) is made available. The following procedure is based on the use of this tool and supposes that the pinion dummy (one of the two pieces) is set in the carrier, without any shims, as shown in Fig. 16-20.

Bevel pinion mounting dummy (A) (09924-36320)

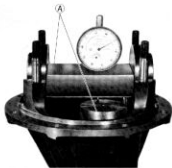

Fig. 16-20

- Set the dial indicator on the dummy, letting the indicator spindle protrude 5 to 6 mm from the bottom of the dummy as shown in Fig. 16-21-1.

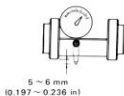

Fig. 16-21-1.

- Rest the dummy on the surface plate, and set the dial indicator to zero. See Fig. 16-21-2. Feed the dummy pinion into the carrier, positioning it properly; and install the joint flange. Secure the joint flange in place by tightening its nut to 70 kg-cm (5.0 lb-ft) torque.

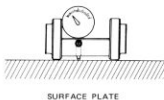

Fig. 16-21-2.

- Referring to Fig. 16-21-3, note that three dimensions are involved: "a" "b" and "c". The value of "b" is unknown, and is to be determined now for calculating the required thickness of shims. The values of "a" and "c" are given: the sum, "a" + "c", is 85 mm, which is indicated on the dummy tool (09924-36320).

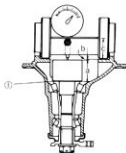

Fig. 16-21-3

With the dummy now secured, the dial indicator hand may have deflected from the "0" mark to show a certain value; read this value, which is the value of "b". Add this reading to 85 mm (= "a" + "c") and, from the sum, subtract the value marked on the bevel pinion. The remainder is the required shim thickness:

$$(85 + "b") - \text{marked value} = \text{required shim thickness}$$



Fig. 16-22

- The shim stock is available in four selective thicknesses. Select and combine shim sizes to produce a total thickness as close to the required thickness as possible, and insert the selected shim pieces into the clearance indicated as Fig. 16-21-3 - ①

Sizes of shims for bevel pinion	0.05, 0.1, 0.3 & 0.5 mm (0.002, 0.004, 0.012 & 0.02 in.)
---------------------------------	---

Bevel pinion bearing preload adjustment

The bevel pinion, as installed in the normal manner in the carrier, is required to offer a certain torque resistance when checked with the use of a prescribed torquing pulley (special tool (A)) as shown in Fig. 16-23. This resistance is a "preload," which is due to the tightness of the two tapered roller bearings by which the pinion is held in the carrier. And this tightness is determined primarily by the thickness of the adjusting collar plus a shim.

Check the preload and, if the preload measurement is off the specified range indicated below, increase or decrease the thickness of the shim. The method is as follows:

Tentatively install the pinion in the carrier, using the adjusting collar and a 1-mm thick shim, and tighten the nut to secure the spined yoke. The nut is to be tightened to the specified torque:

Tightening torque on bevel pinion nut	17 ~ 23 kg-m (123 ~ 166 lb-ft)
---------------------------------------	-----------------------------------

Put on the torquing pulley (special tool) and give a pull, as shown in Fig. 16-23, and read the spring balance indication just when the pulley begins to turn. The reading is a starting torque, and is required to be within the 0.6 to 1.4 kg range (equivalent to the specified torque range of 3.0 to 7.0 kg-m).

Pinion bearing preload	3.0 ~ 7.0 kg-cm (2.6 ~ 6.1 lb-in.)
Starting torque (with pulley)	0.6 ~ 1.4 kg (1.4 ~ 3.1 lb)

Increasing the shim thickness decreases this preload, and vice versa. Four-size shim stock available for "mounting distance" adjustment, mentioned above, is meant to be used in producing a proper shim thickness in this preload adjustment too.

Preload-check torquing pulley (A) (09922-75220)

NOTES:

- When tentatively installing the pinion in the carrier, be sure to oil the bearings lightly with gear oil, and to leave out the oil seal.
- Make a note of the starting torque.



Fig. 16-23 ① Spring measure

Bevel gear backlash adjustment

The backlash between bevel gear and pinion is to be checked in the manner shown in Fig. 16-24. Note that the differential case assembly is mounted in the normal manner, and fastened down by tightening the side bearing cap bolts to the specification torque value. The dial indicator spindle is pointed squarely to the "heel" on the drive side (convex side) of a gear tooth. Hold the bevel pinion rigidly, and turn the gear back and forth.

The dial indicator reading, which is a backlash value, is required to be within this range:

Bevel gear backlash	0.10 ~ 0.15 mm (0.004 ~ 0.006 in.)
---------------------	---------------------------------------



Fig. 16-24

To increase or decrease the backlash for adjustment, displace the bevel gear toward or away from the pinion by running in one adjuster and running out the other adjuster by an equal amount (with the side bearing cap bolts slightly loosened).

Turning the adjuster one notch changes the backlash by about 0.1 mm (0.004 in.).

Side bearing adjuster turner (A) (09923-57910)



Fig. 16-25

CAUTION:

Adjust the preload on the side bearing during backlash adjustment: mount the preload check torquing pulley (A) (09922-75220) on the drive bevel pinion as shown in Fig. 16-23 and measure using spring measure (I). When the reading at the instant the side bevel gear starts moving is within the range as indicated below, the side bearing preload is acceptable. Referring to the graph, for example, when the drive bevel pinion bearing preload measured as indicated in Fig. 16-23 is 1.0 kg (2.21 lb), drive bevel pinion bearing preload (kg) + side bevel gear bearing preload (kg) should be 1.12 – 1.28 kg (2.47 – 2.82 lb).

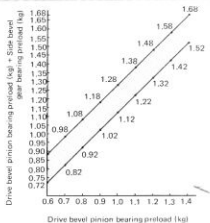

Pinion-to-gear tooth contact pattern check and adjustment

In addition to proper backlash, proper tooth contact must be secured in the mesh of bevel pinion and gear, so that there will be no "gear noise" coming from the axle and that the hypoid teeth will not be overstressed in transmitting drive.

After the specified amount of backlash has been secured, check the pinion and gear for tooth contact by "rolling" contact patterns in a manner consistent with the standard shop practice: use a red lead paste to paint ten teeth, both drive side and coast side, of the gear, turn the gear back and forth by hand while holding the pinion in a "braking" manner, and examine the contact patterns in reference to the following chart:

	Contact patterns	Diagnosis, and what to do
Normal contact pattern		Contact is roughly centered and somewhat more displaced toward toe than toward heel on both drive side (concave) and coast (convex) side.
Patterns due to improper shim adjustment		High contact: Contact is on heel (drive side) and on toe (coast side). This condition means that the pinion is too far back and must be brought forward by increasing its shim thickness used in "mounting distance" adjustment.
		Low contact: Contact is on toe (drive side) and on heel on (coast side). This condition means that the pinion is too far out from the carrier and must be backed away by decreasing its shim thickness.
Pattern due to defective parts		These contact patterns indicate that the "offset" of differential carrier is too much or too little. The remedy is to replace the carrier by a new one.

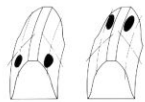
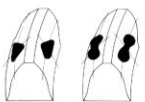
	Contact patterns	Diagnosis, and what to do
Patterns due to defective parts		<p>These contact patterns, located on toe or heel on both drive and coast sides, mean that 1) both pinion and gear are defective, 2) carrier is not true and square, or 3) gear is not properly seated on differential case. The remedy is to replace the defective member.</p>
		<p>Irregular patterns: If the pattern is not oval, it means that bevel gear is defective. High or low spots on tooth surfaces or on the seat of bevel gear are the cause of irregular patterns appearing on some teeth. The remedy is to replace the pinion and-gear set and, if the seat is defective, the differential case also.</p>

CAUTION:

When applying the red lead paste to the teeth, be sure to paint the tooth surfaces uniformly. The paste must not be too dry or too fluid.

16-5. Reassembly Instructions

Tightening torque

	kg-m (lb-ft)
Side bearing cap nut	3.0 ~ 3.7 (22.0 ~ 26.5)
Drive bevel gear bolt	10.0 ~ 11.0 (72.5 ~ 79.5)
Differential case bolt	3.7 ~ 4.5 (27.0 ~ 32.5)
Drive bevel pinion nut	17.0 ~ 23.0 (123.0 ~ 166.0)
Differential carrier nut	1.5 ~ 2.0 (11.0 ~ 14.5)
Oilfiller and drain plug	4.0 ~ 7.0 (29.0 ~ 50.5)



Fig. 16-27

Drive bevel gear bolts

The bolts securing the bevel gear to the differential case are subject to shear stress since drive is transmitted by these bolts from the gear to the case. For this reason, they are special bolts made from chrome steel and must never be replaced by common bolts.

When mounting the gear on the case, be sure to apply the THREAD LOCK CEMENT SUPER 1333B (99000-32020) to these bolts before running them in.



Fig. 16-26

Differential side bearings

Press-fit these bearings into the differential case by using the special tool. Driving the bearing into the case is not permitted.

Differential side bearing installer (A)
(09940-53111)

Bevel pinion bearings

A press must be used to install the two tapered roller bearings on the bevel pinion. Outer races are to be press-fitted into the differential carrier and the inner races onto the pinion.

- (1) For the outer race of front bearing (yoke side), the special tool, indicated here, must be used:

Bearing installer (B) (09913-75520)



Fig. 16-28

- (2) For the outer race of rear bearing (gear side):

Bearing installer A (09913-75510)

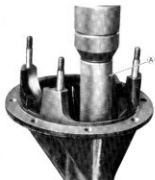

Fig. 16-29

- (3) For the inner races, use this special tool:

Bearing installer B (09913-80111)



Fig. 16-30

Side bearing caps

When putting on the side bearing caps, be sure to discriminate the right-hand cap from the left-hand one by referring to the match marks scribed at the time of disassembly.



Fig. 16-31 ① Scribed match marks

Differential gear oil

The oil capacity of the differential housing is 1.3 litres for both rear and front axle:

Differential housing oil capacity and specification	1.3 litres (2.75/2.31 US/Imp pt) hypoid gear oil SAE #90
---	--



Fig. 16-32 ② Drain plug ③ Oil level plug

17. SUSPENSION

17-1. Description	208
17-2. Barfield Joint Construction and Operation	209
17-3. Removal of Front Wheel and Knuckle	210
17-4. Maintenance Services	211
17-5. Important Steps in Reassembly	213
17-6. Shock Absorbers and Leaf Spring	214

17-1. Description

Suspension is by double-acting shock absorbers and semi-elliptical leaf springs for both axles, front and rear. Similar springs and shock absorbers are used.

The Barfield universal joints are used in the front axle to enable the axle shafts to drive the front wheels while allowing the wheels to be steered. This type of joint provides for a larger steering angle range and, what is more important, constant-velocity drive to the wheel.

If a single two-yoke (or Hooke's) universal joint is used to connect the live axle shaft to the wheel on each side of the front end, the wheels will run with the same speed, but not with the same constant velocity, as that of the axle shafts when the wheels are turned around their kingpins for steering action. The Barfield joint transmits drive without varying the angular velocity of drive.

The Barfield joint is enclosed by the knuckle, which is shaped integral with the wheel hub and knuckle arm, and has a two-piece kingpin, namely, upper and lower kingpins.

The end of the dead axle sleeve is in the shape of a dish. This dish is rotatably fitted into the knuckle structure to form a flexible connection, the sliding clearance between the two being sealed with a felt packing (against road dust and mud) and also with an oil seal (against the oil inside). The upper and lower kingpins, bolted to the knuckle extend into the knuckle and, inside, are held by the dish-like inner case through tapered roller bearings.

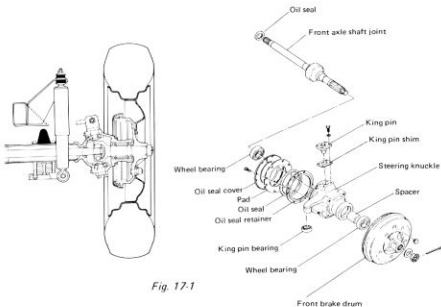

Fig. 17-1

17-2. Barfield Joint Construction and Operation

The major parts of the Barfield joint are the outer race (integral with wheel spindle, to which the wheel disc is splined), inner race (splined to the live axle shaft), six steel balls disposed between the two races, and cage (holding the steel balls in a single row lying in a plane).

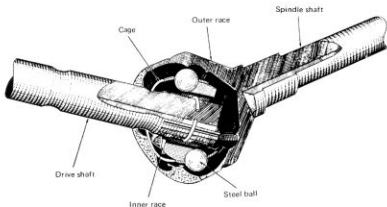

Fig. 17-2

The balls are fitted in two groups of raceways; one group is on the outer race and the other group on the inner race. Each ball is in its own raceways as if it were locked between the two races in the direction of rotation. The outer race with its wheel spindle is capable of angling and, when it so angles with respect to the axis of axle shaft, the row of steel balls angles just half as much, that is, the plane including this row tilts by an angle equal to one-half of the spindle angle. This relationship is illustrated in Figs. 17-3 and 17-4.

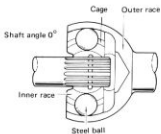

Fig. 17-3

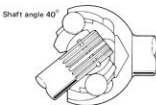

Fig. 17-4

17-3. Removal of Front Wheel and Knuckle

To remove each front wheel and its knuckle, proceed as follows:

- 1) Loosen the five nuts securing the wheel to the wheel disc. Raise the front end by jacking.
- 2) Remove the five nuts and take off the wheel.
- 3) Remove the nut securing the brake drum to the spindle, and pull the drum off by using these special tools:

Front brake drum remover (A) (9943-35511)

Sliding hammer (B) (09942-15510)

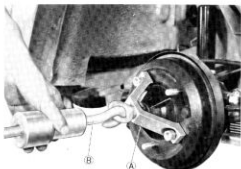

Fig. 17-5

- 4) Remove the four bolts securing the brake backing plate to the hub, and take off the backing plate.

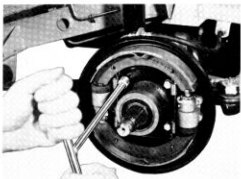

Fig. 17-6

- 5) Remove the tie rod end securing nut, and disconnect the tie rod from the steering knuckle arm. If the stud of tie rod end will not come off easily, put back on the nut, run it in a few turns and tap on the nut with a hammer to drive the stud out.

- 6) Remove the joint seal bolts.
- 7) Remove the upper and lower kingpins. Each kingpin is bolted to the knuckle; removing the four bolts securing the kingpin allows this pin to come off. Pull off the knuckle complete with the spindle, the Barfield joint and live axle shaft.



Fig. 17-7

- 8) Using a press, force the spindle out of the knuckle. This separates the knuckle from the combination of the live axle shaft, Barfield joint and wheel spindle.



Fig. 17-8

17-4. Maintenance Services

Barfield joint

To be checked on this joint is its axial play, which shows up when a push-and-pull motion is given to the live axle shaft and wheel spindle held in both hands, as shown in Fig. 17-9. There should be no play at all but a play of up to 1.5 mm (0.06 in.) is permissible. If the play exceeds the limit replace it.

	Standard	Service limit
Axial play in Barfield joint	0 mm (no play)	1.5 mm (0.06 in.)

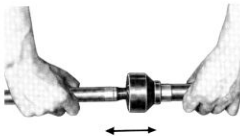

Fig. 17-9

Kingpins

- (1) Inspect each kingpin closely for dents, signs of cracking, distortion or any other damage. Replace the kingpins found in defective condition.



Fig. 17-10

- (2) Where the tapered roller bearings holding the two kingpins at each front wheel are in good and properly preloaded (tightened) condition, there will be no appreciable rattle of the wheel. To check the kingpins and their tapered roller bearings, jack up the front end and shake the wheel to feel any rattle, as shown in Fig. 17-11. If a rattle is felt, eliminate it by properly decreasing the shim thickness. The shim is located between the flanged part of the kingpin and the knuckle.



Fig. 17-11

The above-mentioned method of making a shim adjusting demands a high degree of skill on the part of the serviceman. The alternative method is to adjust the thickness of the shim by referring to the torque resistance which the knuckle arm offers when pulled in the condition shown in Fig. 17-12. For this method, the reference torque value is established, indicated below, and you are to increase or decrease the shim thickness to produce this torque value.

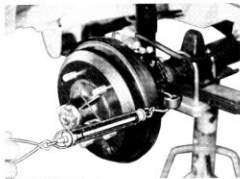

Fig. 17-12 ① Spring measure

Before giving a test pull to the knuckle arm with a spring balance in the alternative method, install a large amount of shims on each kingpin to lighten preload on the tapered roller bearing. Keep on reading the torque, each time decreasing the shim thickness a little, and continue this process until the specified torque value is obtained. (This process protects the kingpins because it ensures that no excessive pull will be applied to the bearings at the onset.) If the process fails to produce the specified torque, that is, if the desired torque resistance does not occur even when the shim thickness has been reduced to zero on each kingpin, it means that the bearings or kingpins are excessively worn and need replacement.

NOTE:

Read the spring balance indication when the knuckle arm begins to turn. In other words, you are to read "starting torque." When checking the knuckle arm starting torque, be sure to have the oil seal removed.

Knuckle arm starting torque (force)	1.0 - 1.8 kg (2.20 - 3.96 lb) without oil seal
Available sizes of shim for kingpins	0.1, 0.5 mm (0.004, 0.02 in.)

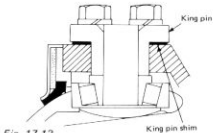

Oil seal

The oil seal used at the spherical sliding joint between the knuckle and the inner case accomplishes the additional purposes of keeping out road dust and of acting as the damper for the steering handwheel. As the wear of this seal advances, its damping effect decreases and thus make the front wheel develop a tendency to "shimmy" not only that road dust begins to creep into the sliding clearance to promote the wear of the spherical sliding surfaces.

The oil seal is an expendable item, and must be replaced at regular intervals.

Oil seal replacement interval	10,000 km (6,000 miles)
-------------------------------	-------------------------



Fig. 17-14

How to replace the oil seal:

- ① Remove the 8 bolts securing the joint seat, and displace the oil seal cover and felt packing inward.
- ② Cut the oil seal in place with scissors or a knife, and take it off.
- ③ Cut the replacement oil seal at one place with scissors or a knife as shown in Fig. 17-15.
- ④ Install the seal in the oil seal retainer, bringing the cut portion to top side and locating it about 30 degrees off the matching face of the oil seal retainer.



Fig. 17-15

- ⑤ Apply the sealing compound to the mating face all around: this is for preventing entry of water.

SEALING COMPOUND "CEMEDINE"
366E (99000-31090)

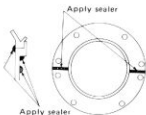

Fig. 17-16

17-5. Important Steps in Reassembly

Wheel spindle

To install the spindle in the hub, which is integral with the knuckle, use the special tool, as shown in Fig. 17-17. This tool takes a grip on the hub; turning its bolt forces the spindle into the knuckle.

Front wheel spindle installer (A) (09924-46310)

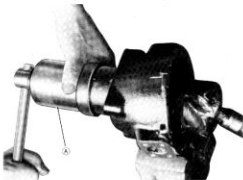

Fig. 17-17

Knuckle

When fitting the knuckle to the inner case, make the space inside the case and knuckle 30% full with SUZUKI SUPER GREASE H (MOLY-COTE type).



Fig. 17-18

NOTE:

When mounting joint seal stopper bolts (1), which are a little longer than other bolts, after replacement of steering knuckle oil seal, pay special attention to the mounting position. Both bolts on right and left should be mounted in such a way that they contact rear side of front axle housing when rotating steering wheel all the way to the right or left. Incorrect mounting of the bolt (1) causes incorrect turning radius, resulting in danger.

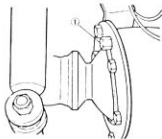
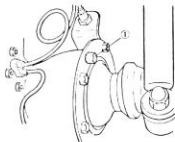

Kingpins

The sealing compound is to be used on kingpins. Just before installing the kingpin, apply the compound to the corner inside the flange, with the shims in place, as shown in Fig. 17-19. This is for preventing water from finding its way into the knuckle through the fit the kingpin in the knuckle.

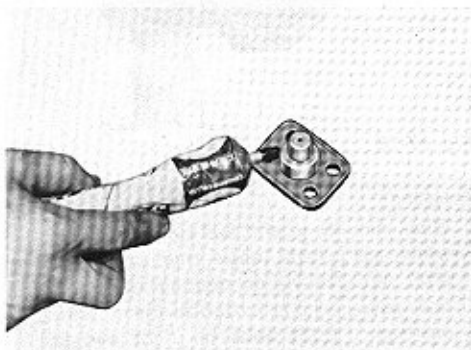

Fig. 17-19

Brake backing plate (Front and rear)

Apply CEMEDINE "366E" (99000-31090) to the matting surface of the steering knuckle (rear axle housing) and the brake backing plate.

17-6. Shock Absorbers and Leaf Spring

Specifications

SHOCK ABSORBERS

Item	Front shock absorbers	Rear shock absorbers
Damping force on rebound	60 kg (132 lb)	60 kg (132 lb)
Stroke	150 mm (5.90 in.)	160 mm (6.30 in.)

*The force is based on piston speed of 0.3 m/second.

LEAF SPRINGS

Item	Front leaf springs	Rear leaf springs
Amount of bow	-4.5 mm (-0.18 in.)	86.0 mm (3.38 in.)
Leaf length	940 mm (37.00 in.)	1,000 mm (39.37 in.)
Spring rate	4.50kg/mm	3.03kg/mm

NOTE:

In the above table, "amount of bow" assumes the machine to be in non-loaded condition, and refers to right-hand traffic machines (with the steering wheel located on the left-hand side). For left-hand traffic machines, the amount of bow for rear leaf springs differs from the above specification, as follows:

Left rear leaf spring . . . 73.5 mm (2.89 in.)

Right rear leaf spring . . . 86.0 mm (3.38 in.)

Inspection

(1) Shock absorbers

The absorbers are of double-acting type. By trying to contract and extend each absorber by hand, the effectiveness of its damping action can be told. Absorbers found with oil leak or with inadequate damping effectiveness must be replaced.



Fig. 17-20

(2) Leaf springs

If any leaf spring is suspected of weakening, as evidenced by the chassis being tilted to one side in standstill condition on level ground, check its dimension "L", the distance between its center part and the line through the two attachment eyes, shown in Fig. 17-21. If this distance measures less than the limit, replace the spring.

Item	Front spring(W)	Rear springs (L)
Limit on leaf spring bow	-15.0 mm (-0.59 in.)	Right-hand traffic machine 74.5 mm (2.93 in.) for both right and left springs
		Left-hand traffic machine 74.5 mm (2.93 in.) for right spring 62.0 mm (2.44 in.) for left spring

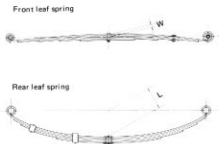

Fig. 17-21

Tips on installation

In the bottom connection of each shock absorber, two washers are used. When making this connection, check to be sure that each washer in place has its flange pointing outward, as shown in Fig. 17-22. If these washers are mispositioned, the shock absorber may fail in service.

After installing all the shock absorbers, go around and recheck each connection for washer position.

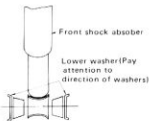

Fig. 17-22

18. STEERING SYSTEM

18-1. Description	218
18-2. Specifications and Data	218
18-3. Steering Gear Box Construction and Operation	219
18-4. Removal	220
18-5. Maintenance Services	221
18-6. Important Step in Reassembly	223
18-7. Wheel Alignment	224

18-1. Description

The steering movement of the handwheel is transmitted to the drag link through the steering gear box and its pitman arm. The drag link moves linearly to turn the steering tie-rod lever, and this lever actuates the two tie rods, right and left, to turn the front wheels through their knuckle arms. The turning force exerted by the tie rod experiences a damping action due to the presence of the oil seal at the spherical joint between the knuckle case and the inner case (integral with the dead axle sleeve). Another damping action is available, which will be mentioned below.

The steering system formed by the components named above is designed for easy steering, high durability and excellent steering reaction as well as reliable self-restoring action. Articulated joints in the steering lever is equipped with a damping device for ensuring the greater steering stability.

linkage are of wear-resistant ball-and-socket type. The steering tie rod lever is equipped with a damping device for ensuring the greater steering stability.

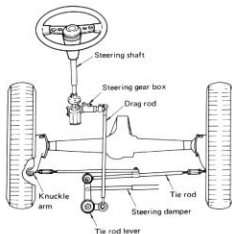

Fig. 18-1

18-2. Specifications and Data

Steering gear box	Recirculating ball-and-nut type
Gear ratio	15.6
Steering angle, inside	27°
Steering angle, outside	24°
Steering wheel diameter	400 mm (15.74 in.)
Minimum turning radius	4.9 m (16.1 ft.)

18-3. Steering Gear Box Construction and Operation

The pitman arm is rigidly connected to the outer end of the shaft integral with the sector gear, which is inside the gear box and meshed with the teeth of the nut capable of sliding along the worm. Between the nut and the worm is a row of steel balls (actually a total of 60 balls are used), which serves two purposes: to provide rolling contact between nut and worm and to keep the nut engaged with the worm as if the two were threadedly engaged. With the nut prevented from turning, the rotation of the worm causes the nut to move up or down the worm.

The worm is an extension of the steering shaft. As the handwheel is turned, the steel balls roll along in the groove and the nut moves up or down. The steel ball that has reached the end of the groove in the nut enters the return guide. The guide sends the ball back to the other end of the same groove. In this way, the row of balls recirculates.

By so moving, the nut turns the sector gear and hence the pitman arm. It should be noted here that it is through the steel balls that a rotary motion of the worm is converted into a linear motion of the nut, which is then converted into another rotary motion of the sector gear.

The steering gear box is a precision-machined device, each part of it being machined to a closer tolerance for smooth conversion of motion, and is built sturdy for long service life. Special tools and instruments are needed in addition to specialized skill if the gear box is to be overhauled. For this reason, a gear box found to be in defective condition should be replaced by a new one; replacement is more economical and, what is perhaps more important, safer.

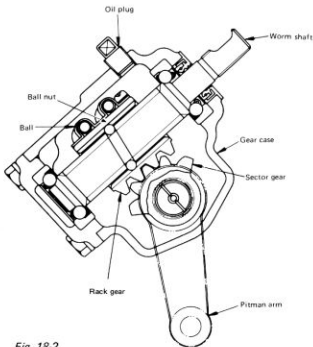

Fig. 18-2

18-4. Removal

1) Steering handwheel

At the steering handwheel, depress the horn button while twisting it counter-clockwise, to remove the button. After removing the button, remove the nut securing the handwheel, and pull the handwheel off. The handwheel is splined to the shaft.



Fig. 18-3

2) Steering shaft

Loosen the bolts on the rubber joint flange at the bottom end of the steering shaft.



Fig. 18-4

Remove the two bolts fastening the rubber joint to the steering shaft.



Fig. 18-5

Disconnect the wiring harness, and remove the two brackets fastening the steering column to the body. Pull up the steering shaft and take it off at the driver's seat.

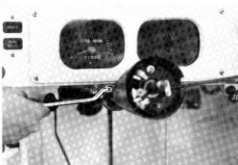

Fig. 18-6

3) Gear box

Disconnect drag link from pitman arm. If the link will not come off easily, give two or three light hammer blows to the face ① of pitman arm and tap on the stud lightly to shake the connection loose. This will help the link ball stud slide off the arm.



Fig. 18-7

The steering gear box is secured in place by three mounting bolts. Remove these bolts and take down the gear box.



Fig. 18-8

18-5. Maintenance Services

Steering handwheel play

The wheel play is proper if it is anywhere between 10 and 30 mm (0.4 and 1.2 in.) as measured at the rim. An unusually large play means that the ball-and-socket joints are loose or that the wear in the steering gear box is excessively large.



Fig. 18-9

Steering gear box

- 1) If any evidence of oil leakage is noted on the gear box upon inspection of the machine brought in for servicing, remove the plug (Fig. 18-10) and check the level of oil inside. The oil surface should be up to about 6 mm (0.24 in.) below plug; if not, add oil. Be sure to use the prescribed gear oil, SAE 90.

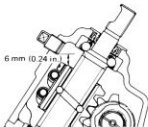

Fig. 18-10

- 2) The adjusting bolt on the steering gear box is for giving a preload to the worm shaft. If this shaft is noted to have any rattle, check its starting torque by using a spring balance, and tighten adjusting bolt (1), Fig. 18-11, to obtain the specified torque.

CAUTIONS:

- When making this adjustment, be sure that the steering gear box is in the position for straightahead rolling; gear teeth in the gear box might break off as the adjusting bolt is tightened, if the gear box is off this center position.
- Have the drag link and steering shaft disconnected from the gear box. The starting torque specification refers to the gear box as an individual component.

Starting torque of worm shaft	2.0 - 5.0 kg-cm (0.145 - 0.360 lb-ft)
-------------------------------	--



Fig. 18-11

Steering rubber joint

Inspect the rubber joint for evidence of crack or breakage, and make sure that its bolts are tight.

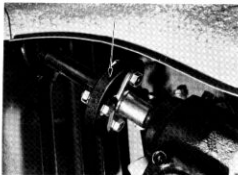

Fig. 18-12

Steering tie rod lever & tie rod.

Be sure that the top and bottom oil seal lip portions in the tie rod lever are adequately greased; if not, apply SUZUKI SUPER GREASE A (99000-25010).

See if the tie rod lever has any rattle and, if so, replace the part responsible for the rattle. Visually inspect the tie rod for bowing and rattle and, as necessary, replace it.

The oil seals must be relubricated with the above-named grease at intervals of every 10,000 km (6,000 miles).

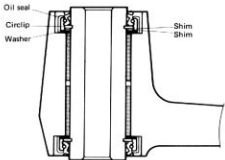

Fig. 18-13

Wheel and hub nuts

Inspect each wheel disc for cracks, dents and distortion. A disc in badly damaged condition must be replaced. Check the wheel hub nuts for tightness and, as necessary, retighten them to the specification.

Tightening torque for wheel hub nuts	5.0 - 8.0 kg-m (36.5 - 57.5 lb-ft)
---	---------------------------------------



Fig. 18-14

Tires

A tire badly worn, torn or otherwise deteriorated must be replaced. Check the inflating pressure of each tire and, as necessary, adjust the pressure to the specification.

Properly inflated tires are one of the keys to satisfactory cruising performance. Be sure to advise the user about the importance of keeping the tires inflated to the pressures specified.

Tire service limit	Less than 1.6 mm (0.063 in.) depth of tread at two places.
--------------------	--

NOTES:

- Markings so-called “wear indicator” being attached to the tires, the tires must be replaced when these marks become visible.
- When replacing the tires, choose tires to suit road and working conditions.

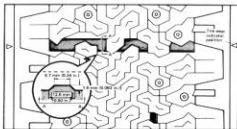

Fig. 18-14-1

CAUTION:

After adjusting the tire pressure, check to be sure that the air valve is free from any signs of leakage.

Tire pressure specification

Wheel	Non-load condition	Loaded condition
Front wheel tires	1.2 kg/cm ² (17 psi) (120 kPa)	1.4 kg/cm ² (20 psi) (140 kPa)
Rear wheel tires	1.6 kg/cm ² (23 psi) (160 kPa)	2.0 kg/cm ² (29 psi) (200 kPa)

“Rotate” the tires at the regular intervals, stated below, in order to equalize tire wear and thereby make full use of each tire. Refer to Fig. 18-15 for the scheme of rotation. Adherence to this scheme prolongs tire life.

Tire rotation interval	Every 10,000 km (6,000 miles)
------------------------	----------------------------------

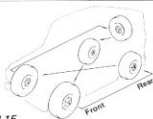

Fig. 18-15

18-6. Important Step in Reassembly

Tie rod turnbuckles

After installing the two tie rods to connect the tie rod lever to the two knuckle arms, right and left, rotate the two turnbuckles equally to obtain the specified toe-in. “Equal rotation” means that the exposed thread portions ① of one turnbuckle are equal in length to those of the other turnbuckle.

Toe-in specification	1 - 5 mm (0.040 - 0.196 in.)
----------------------	---------------------------------



Fig. 18-16

Steering handwheel

Two requirements must be met, among others, in installing and setting the steering wheel: 1) check to be sure that the hand-wheel play meets the specification, and 2) set it in such a way that, with the front wheels pointing straightahead, its two spokes are horizontal, as shown in Fig. 18-17.



Fig. 18-17

Steering column cover clearances

Two clearances are specified for the column cover; the clearance between the cover and the instrument panel must be about 3 mm (0.12 in.) and that between the cover and the handwheel must be just as wide (3 mm or 0.12 in.).

The former clearance is to be secured by properly positioning the steering column, and the latter by inserting the steering shaft more or less into the steering rubber joint.

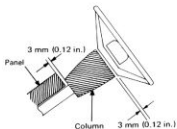

Fig. 18-18

18-7. Wheel Alignment

Alignment service data

Toe-in	1 - 5 mm (0.040 - 0.196 in.)
Camber	1 degree (1°)
Trail	10 mm (0.40 in.)
Kingpin inclination	9 degree (9°)
Caster	2 degree (2°)

Max. difference between right and left caster angles: 1°

Adjustment

The only item of adjustment is toe-in. Camber and caster are given and fixed. Before checking and adjusting toe-in, let the car stand on flat level ground without any load placed aboard, and make sure that -

- (1) All tires are inflated to the following pressures:

Unloaded

Front wheel tires	1.2 kg/cm ² (17 psi)(120 kPa)
Rear wheel tires	1.6 kg/cm ² (23 psi)(160 kPa)

- (2) The car is level. (Check by using a carpenter's level gauge.)
- (3) The front wheels are set in straightahead driving position.
Using the toe-in gauge, read the toe-in and compare the reading against the specification (indicated above). To increase or reduce the toe-in, vary the length of each tie rod by means of its turnbuckle ①

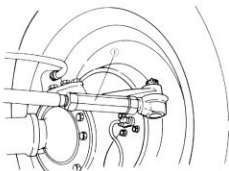

Fig. 18-19



Fig. 18-20

19. BRAKES

19-1. Description	226
19-2. Tandem Master Cylinder	227
19-3. Tandem Master Cylinder Operation	227
19-4. Front Brake Construction	229
19-5. Rear Brake Construction	229
19-6. Center Brake Construction	229
19-7. Wheel Cylinder Construction	230
19-8. Maintenance Services	230

19-1. Description

The hydraulic foot brake system of the LJ80-LJ80V has two leading shoes in the front wheel brakes, and one leading shoe and one trailing shoe in the rear wheel brakes. Hydraulic pressure is produced by a tandem master cylinder to actuate the wheel cylinders, two in each front wheel brake and one in each rear wheel brake, through two independent circuits, one for front brakes and one for rear brakes.

The parking brake system is mechanical; it consists of the brake drum mounted on a propeller shaft (at the transfer gear box) and the internally-expanding two-shoe brake assembly (whose backing plate is bolted to the gear box). Called the center brake, this brake is controlled from the parking lever through a cable.

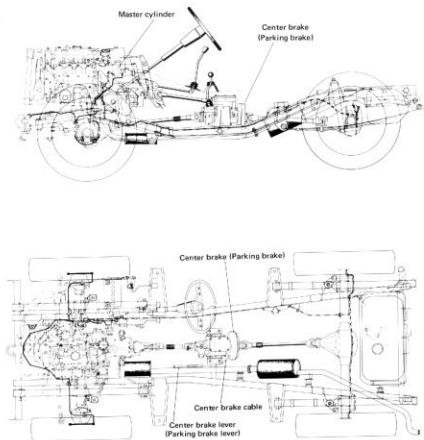

Fig. 19-1

19-2. Tandem Master Cylinder

The tandem master cylinder is similar in construction to an ordinary master cylinder, the principal differences being that it has two pistons and four piston cups and that hydraulic pressure is developed in two chambers, one for front brakes and the other for rear brakes.

Obviously the two-circuit foot brake system employed in the LJ80 and LJ80V models assures greater safety; failure of one circuit (failure of front brakes or rear brakes) due to such as an oil line rupture does not incapacitate the machine.

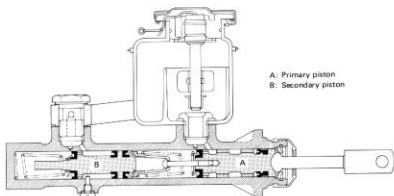

Fig. 19-2

19-3. Tandem Master Cylinder Operation

Normal operation

Depressing the brake pedal forces primary piston "A" toward the left (in Fig. 19-3) to pressurize the oil immediately ahead for front brakes. By this pressure and by the force of return spring, secondary piston "B" moves similarly to pressurize the oil for rear brakes.

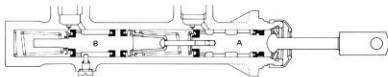

Fig. 19-3

One-circuit operation (front-brake circuit failure)

Depressing the brake pedal causes primary piston "A" to move as above but, because the front-brake circuit cannot hold pressure, the oil immediately ahead of this piston does not get pressurized. As piston "A" keeps moving, compressing the spring, it begins to push piston "B" when the spring has been compressed fully. From this point on, piston "B" moves to pressurize the oil ahead and thus actuate the rear brakes.

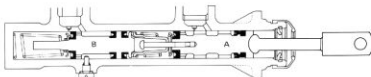

Fig. 19-4

One-circuit operation (rear-brake circuit failure)

In this case, the leftward movement of piston "A" has but little effect in pressurizing its oil (for front brakes) at first, because the initial rise in oil pressure causes piston "B" to promptly yield and move toward the left. Very soon the forward end of piston "A" comes to and bears against the head of the cylinder. From this point on, the leftward movement of piston "A" becomes effective to pressurize the oil ahead of it for the front brakes. Fig. 19-5 shows secondary piston "B" at halt.

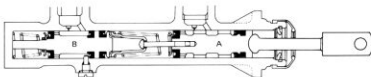

Fig. 19-5

19-4. Front Brake Construction

There are two wheel cylinders. Each cylinder has one piston, by which it pushes the leading end of its shoe. In other words, the two shoes begin to rub the drum in a "biting" manner the moment the hydraulic pressure applies to the wheel cylinders, and thus develop greater braking force more quickly as the pressure to the cylinder rises (when the machine is running forward).

The shoes are mounted on the backing plate in a floating manner, each being urged by the return spring in the contracting direction and pivoted at its trailing end.

Each wheel cylinder is complete with an adjuster consisting of a notched wheel and a bolt. Turning this wheel advances or retracts the bolt (on which the trailing end of the shoe pivots) to reduce or increase the shoe-to-drum clearance (brake adjustment). The two cylinders are bolted to the backing plate; and their adjusting wheels are accessible through holes provided in the brake drum.



Fig. 19-6

19-5. Rear Brake construction

The rear brake has a double-piston type wheel cylinder interposed between the leading end of one shoe and the trailing end of the other. The other ends of these shoes pivot on the adjuster sleeve complete with an adjusting screw.

When hydraulic pressure applies to the wheel cylinder, which is bolted to the backing plate, the two pushrods of this cylinder move out to spread the shoes apart against the force of two return springs.

Brake adjustment is to be effected by turning the notched screw of the adjuster sleeve. This screw is accessible through a hole provided in the brake drum.



Fig. 19-7

19-6. Center Brake Construction

The major parts of this brake are the adjusting sleeve, brake shoe lever, shoe strut, shoes and return springs, all mounted on the backing plate. The drum is splined to the propeller shaft (No. 1). The strut, corresponding to the wheel cylinder in a wheel brake, is mechanically turned to expand the two shoes apart and thereby to develop braking force by the rubbing contact of their shoe linings against the drum.



Fig. 19-8

19-7. Wheel Cylinder Construction

The double-piston cylinder used in the rear brake has two pistons, each backed by a cup and fronted by a boot. a pushrod or actuating pin bears against the piston by its inner end and is fitted to the shoe web by its outer end.

The single piston cylinder, two of which are used in the front brake, is similar to the double-piston one, except that it has one piston, with its other end being complete with the adjuster.

A bleeder screw is provided in the cylinder proper. This screw is a plug; it is to be removed only when air trapped in the circuit has to be vented out.

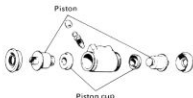

Fig. 19-9

19-8. Maintenance services

Master cylinder

Complaints on the master cylinder are in most cases traceable to excessively worn piston cups or improperly seating check valves; experience tells us that the primary cause of these malconditions is the impurities, particularly abrasive or gritty matters, that have entered the brake fluid reservoir. Check the master cylinder for the possibility of these malconditions. The internals of the master cylinder should be replaced at regular intervals, and they should be handled as a kit. The recommended interval is two years.

Master cylinder internals replacement interval	2 (two) years
--	---------------

Master cylinder pistons kit



Fig. 19-10

The overall length of the primary piston sub-assembly is specified to be 93.1 mm (3.665 in.). This specification assumes great importance in the function of the master cylinder. When rebuilding this sub-assembly after its disassembly for overhaul or for replacement of piston cups, be sure to set the overall length to the specification value by means of the forming screw.

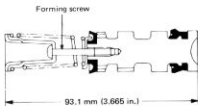

Fig. 19-11

Brake drum

Inspect the drum for cleanliness. Remove oil stains, if any. Check the wear of its braking surface by measuring its inside diameter, and determine its "out-of-round" from ID readings. The braking surface with groovy wear can be repaired by turning in a lathe if machining stock is available; a minor "out-of-round" can be corrected also by turning. A drum cracked or distorted or worn beyond repair must be replaced.

	Standard	Service limit
Brake drum inside diameter	210 mm (8.26 in.)	212 mm (8.34 in.)
Brake drum "out-of-round"	0	0.5 mm (0.02 in.)



Fig. 19-12

Brake shoes

Glazed surfaces, if any, of brake shoes can and must be reconditioned by grinding with sandpaper. Oil stains too can be removed similarly. Where the lining is worn beyond the service limit, the shoe must be replaced.

Brake lining thickness (lining + shoe rim)	Standard	Service limit
	6.8 mm (0.27 in.)	3.0 mm (0.12 in.)

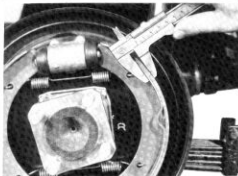

Fig. 19-13

Master cylinder and wheel cylinders

Inspect piston cups for wear and for evidence of deterioration, and replace them if found in defective condition, even when the end of the regular replacement interval is ahead.

The internals of each cylinder are to be replaced as a kit at regular intervals.

Piston cups and boots are of rubber; they must not be washed with gasoline or similar washing fluid. Use the brake fluid to wash them, or they may distort or swell.

Cylinder internals replacement interval	2 (two) years
---	---------------

Wheel cylinder
pistons kit



Fig. 19-14

Brake pipes

The brake pipes are double-layer wound type, made by rolling steel strip into a two-layer wall pipe, with its surfaces treated for rust prevention. After driving the machine along in sea water at the beach or in a shore area full of salt sprays, it is a good practice to wash the brake pipes with soft water.

Inspect the brake pipes in regard to the following items
(1) Cut marks or dents
(2) Leakage of brake fluid
(3) Signs of rubbing at the clamps and clips
(4) Rusting or corrosion

Air purging

Whenever any component or part of the foot brake system has been replaced, reconnected or otherwise worked on to expose the brake-fluid side of the circuit to the atmosphere, some air will get into the circuit; and the presence of such air will result in a "spongy" brake pedal. In such a case, or whenever the presence of air in the circuit is suspected, carry out an "air purging" operation at each wheel cylinder, as follows:

- (1) Tie a transparent vinyl tube (1) into the bleeder plug of the wheel cylinder (in order to catch the brake fluid).
- (2) Pump the brake pedal several times and depress the pedal all the way.
- (3) Loosen the bleeder plug by turning it a half rotation. The fluid with air bubbles will come out. Tighten up the plug when air bubbles stop coming out.

This operation requires two persons, one at the brake pedal and one at the wheel cylinder.



Fig. 19-15

Brake fluid

The brake system uses a glycol type brake fluid. When purchasing the replacement fluid, be sure to specify the glycol type meeting the following specifications:

Brake Fluid	Specifications
	DOT 3, DOT 4

Some commercially available brake fluids are of silicone or petroleum base; do not use any of these fluid. Remember, any brake fluid which is a mixture of two or more brands is likely to effect some of the brake system components adversely, resulting in faulty braking.

The brake fluid in service is subject to gradual deterioration because the moisture content of air finds its way slowly into the brake fluid. For this reason, the brake fluid should be regarded as an expendable item and be replaced at regular intervals.

Brake fluid change interval	2 (two) years
-----------------------------	---------------

Brake shoe clearance adjustment

The hole for gaining access to the adjusting wheel or screw is provided in the brake drum. Through this hole, insert a screwdriver to turn the adjusting wheel or screw.

Turn the wheel or screw to expand the shoe all the way, locking hard the brake drum, and then turn it back 3 to 6 notches to introduce a drum-to-shoe clearance. Leave the adjusting wheel or screw right there.

Brake shoe clearance adjustment	Back away 3 to 6 notches
---------------------------------	--------------------------

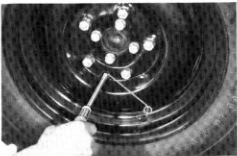

Fig. 19-16. (1) Adjusting hole

Brake pedal

Confirm that clearance (2) between the wall and the pedal arm is more than 50 mm (1.97 in) when the pedal is depressed by a load of approx. 30 kg (66 lb). If the clearance is less than 50 mm (1.97 in), adjust the brake shoe clearance to obtain the specified value.

CAUTION:

- If the specified clearance cannot be obtained, or the feel is spongy when the pedal is depressed, check the shoes for excessive wear and the brake system for air entered.
- After reassembling the brake oil line, bleed air from the line.

NOTE:

Inspect pedal clearance daily, as well as at periodically scheduled inspection.

Pedal travel	15 ~ 20 mm (0.59 ~ 0.78 in.)
Pedal-to-wall clearance (2) (when pedal is depressed at 30 kg (66 lb))	50 mm minimum (1.97 in.)

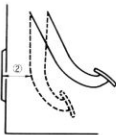

Fig. 19-17

Parking brake lever

Pull up the parking brake lever all the way with one hand to apply brake fully, and see how many notches of the ratchet the lever has traversed. If the number of traversed notches is more than 7 (seven), adjustment must be made at the center brake to reduce the shoe-to-drum clearance.

Through the hole provided in the brake drum, insert a screwdriver and back away the adjusting screw 3 to 6 notches from its zero-clearance position, as in the case of the wheel brake.

Parking brake stroke③	7 notches maximum
Brake shoe clearance adjustment	Back away 3 to 6 notches



Fig. 19-18

Parking brake cable

Inspect the brake cable for damage, and check for smoothness of its movement. Oil the cable as necessary. A defective cable must be replaced. Advise the user to inspect and service the cable in this manner at regular intervals.

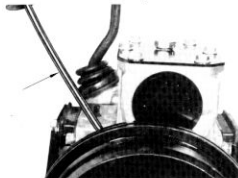

Fig. 19-19

Brake hoses and pipes

These are critical safety parts and demand greater attention. Be always sure that the hoses and pipes are in good condition, free of any evidence of crack or breading. A damaged hose or pipe or a rusted or leaking one must be replaced.

CAUTION:

After replacing any of the brake pipes or hoses, be sure to carry out an air bleeding operation. You are duty-bound to do this before releasing the serviced machine to the user.

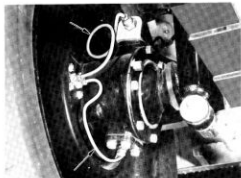

Fig. 19-20

20. DOOR

20-1. Description	236
20-2. Door Disassembly (LJ80V)	237
20-3. Inspection and Adjustments (LJ80V)	239

20-1. Description

The difference between Model LJ80 and Model LJ80V is mainly in the body top. The former has a tarp top of readily removable type, the latter a steel top with windows and doors.

The door window glass of LJ80V is capable of sliding up and down in the window as controlled by the window regulator. Doors can be removed, and can be disassembled to the extent of permitting replacement of the door glass, regulator, door lock, etc.

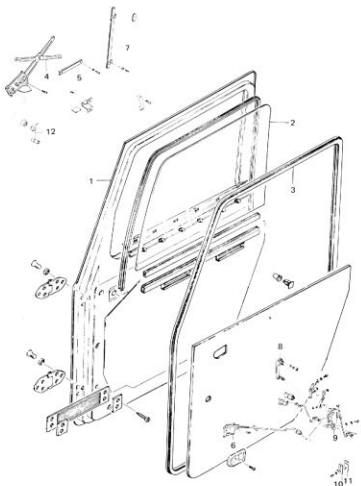

1. Front door panel ass'y
2. Door glass
3. Weatherstrip
4. Regulator
5. Regulator roller holder
6. Remote control

7. Sash
8. Outside handle
9. Door lock ass'y
10. Door lock striker
11. Striker spacer
12. Regulator handle

Fig. 20-1

20-2. Door Disassembly (LJ80V)

The procedure to be followed in removing the internal parts of the door is as follows:

- 1) Remove door-window regulator handle.

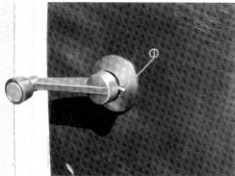

Fig. 20-2 ① Pin

- 2) Remove inside handle case.



Fig. 20-3

- 3) Remove inside pull handle.



Fig. 20-4

- 4) Loosen two screws securing the stopper band, and take off the band.

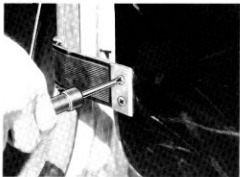

Fig. 20-5

- 5) Remove nine clips holding the door trim board to the door, and take the board off.



Fig. 20-6

- 6) Remove the glass scraper.

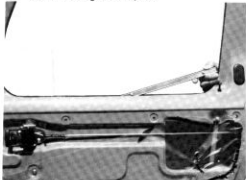

Fig. 20-7

- 7) Lower the window glass, and remove 4 screws securing the window regulator.



Fig. 20-8

- 8) Remove two screws securing door sash.

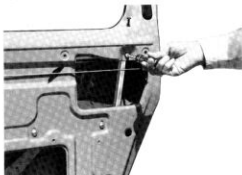

Fig. 20-9

- 9) Remove the roller holder of window regulator.

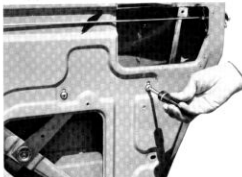

Fig. 20-10

- 10) Remove door glass stop plate.

NOTE:

Hold the glass with one hand, so that it will not drop as the plate comes off.



Fig. 20-11

- 11) Take out the glass.



Fig. 20-12

- 12) Remove the window regulator.



Fig. 20-13

20-3. Inspection and Adjustments (LJ80V)

Outside door handle

See if the outside door handle has an abnormally large rattle or works erratically or fails to open the door satisfactorily; inspect the operating parts for wear, breakage and distortion and replace defective parts, if any. To adjust the position of this handle, loosen the two screws, Fig. 20-14, to set it right.



Fig. 20-14

Door lock striker

A door not opening and closing positively or smoothly usually means that the lock striker is out of adjustment. If the door frame is not parallel to the cabin, the striker and lock must be inspected for the cause, which is usually worn-down, cracked or broken parts. Replace defective parts, if any.

Loosening two screws securing the striker allows the striker to be moved in place. Move the striker up and down and sidewise to locate its correct position, set it right there and secure it by tightening the screws.

NOTES:

- If the striker refuses to be adjusted as above, increase or decrease the thickness of the spacer within the striker.
- If all attempts fail to adjust the striker, the final cause is very likely an improperly hinged door or distorted hinges. Replace distorted hinges.



Fig. 20-15

Window regulator

If the window regulator is faulty, the window glass will not smoothly rise or it lowers from its position while the vehicle is running. This may be due to a fatigue of balance spring or broken pinion or lack of grease. If either of the balance spring and pinion is found faulty, they should be replaced as an assembly.



Fig. 20-16

Door window glass

When raising or lowering door window glass is abnormally heavy, door window glass is often fitted aslant into door frame and rail. Correct this trouble by moving up and down screws attaching door window regulator arm shown in the Fig. 20-17.



Fig. 20-17

21. BODY ELECTRICAL EQUIPMENT

21-1. Wiring Diagram	244
21-2. Head Light	245
21-3. Turn Signal Light and Hazard Warning Light	247
21-4. Windshield Wiper Motor	248
21-5. Fuel Gauge	250

21-1. Wiring Diagram

If the cause of electrical trouble is suspected to reside in the wiring, something like a road map is needed to clear one part after another of the wiring in order to come to the point in fault. The diagram of Fig. 21-1 is such a road map.

The diagram indicates whereabouts of line and terminal connections, and identifies electrical lines by coded colors. Be sure to have the diagram right beside you when you go about checking the electrical lines for "open," "short" and "ground." Remember, loose connections are responsible for the trouble in most cases.

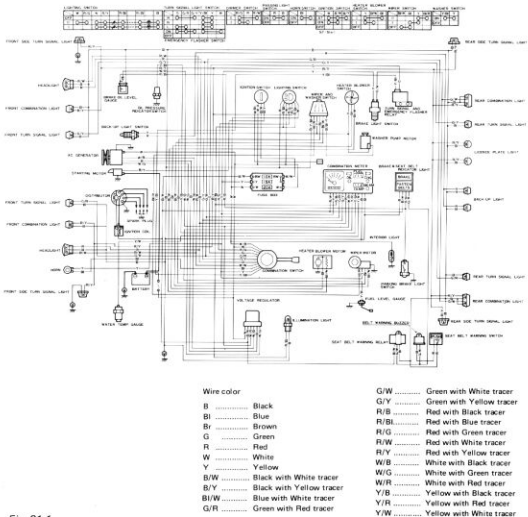

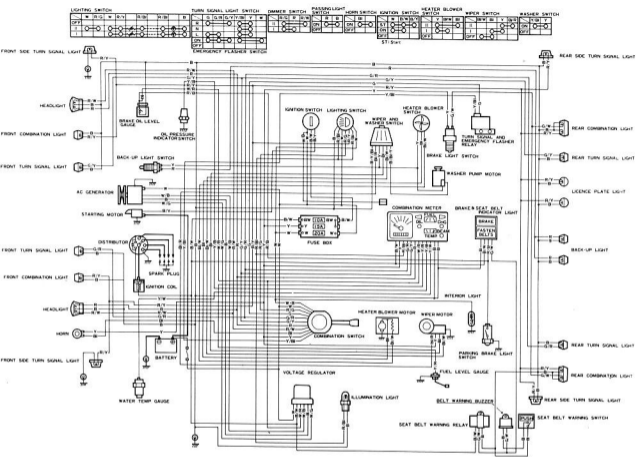

Wire color

B	Black
Bl	Blue
Br	Brown
G	Green
R	Red
W	White
Y	Yellow
B/W	Black with White tracer
B/Y	Black with Yellow tracer
Bl/W	Blue with White tracer
G/R	Green with Red tracer

G/W	Green with White tracer
G/Y	Green with Yellow tracer
R/B	Red with Black tracer
R/Bl	Red with Blue tracer
R/G	Red with Green tracer
R/W	Red with White tracer
R/Y	Red with Yellow tracer
W/B	White with Black tracer
W/G	White with Green tracer
W/R	White with Red tracer
Y/B	Yellow with Black tracer
Y/R	Yellow with Red tracer
Y/W	Yellow with White tracer

Fig. 21-1

21-2. Headlight

Wiring circuit

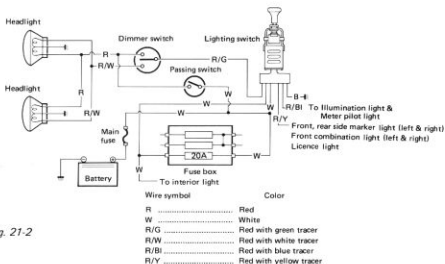

Fig. 21-2

Headlight inspection

1. Lighting (Low beam, High beam, Passing)
2. Mounting
3. Dirt and cracks on lenses
4. Main beam axis direction and brightness

Headlight beam setting (standard)

Before measuring or adjusting the headlight beam, adjust air pressure of the 4 tires to the specified value and settle the attitude of the vehicle by manually moving it up and down, then move the vehicle onto a flat surface. There are various measuring methods (e.g. screen method, using focusing type tester, etc.). The method described in this manual does not use a tester.

(1) Vertical beam alignment

Unless otherwise prescribed by the local statutory regulations, set the headlights in such a way that the main beam axis will fall on a spot not above the height of the headlight and not below a height equal to a fifth (1/5) of the headlight height. In other words, the main beam should be sloped down. The beam spot, mentioned above, refers to a blank wall standing vertical 10 meters (32.8 feet) ahead of the headlights, with the vehicle standing perfectly level.

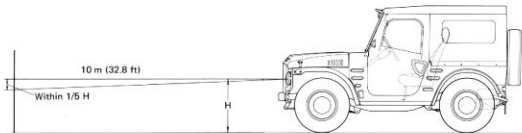

Fig. 21-3

(2) Horizontal beam alignment (Left-hand drive vehicle)

The set-up is the same as in Fig. 21-3. For the right-hand drive model, the alignment is the mirror image of that prescribed here.

LEFT HEADLIGHT: Determine the point straight ahead of the headlight, and align the main beam axis so that the axis will strike a spot within 100 mm (3.94 in.) to the left or 200 mm (7.87 in.) to the right of the straight ahead point.

RIGHT HEADLIGHT: Determine the point straight ahead of the headlight, and align the main beam axis so that the axis will strike a spot within 200 mm (7.87 in.) on either side of that point.

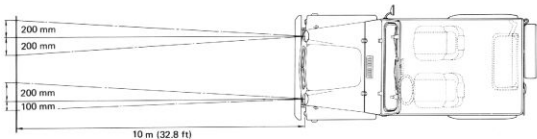

Fig. 21-4

Maintenance

(1) Headlight adjustment

There are two screws; 1, and 2. By means of these screws, adjust the headlight position for beam alignment.



Fig. 21-5

(2) Headlight dimmer switch

Check continuity between terminals with a circuit tester:

At LOW BEAM, continuity must be obtained between Red/green (4) and Red/white (6) terminals.

At HIGH BEAM, continuity must be obtained between Red/green (4) and Red (5) terminals.



- | | |
|-----------------|----------------|
| 1. Green/red | 7. White |
| 2. Green/yellow | 8. Yellow |
| 3. Green | 9. Yellow/blue |
| 4. Red/green | 10. Blue |
| 5. Red | 11. Black |
| 6. Red/white | 12. Black |

Fig. 21-6

21-3. Turn Signal Light and Hazard Warning Light

Circuit description

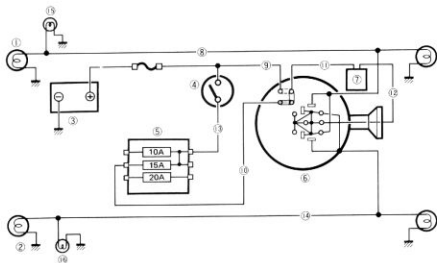

- | | | |
|------------------------------|---------------------|--------------------------------|
| 1. Right turn signal | 2. Left turn signal | 3. Battery |
| 4. Main switch | 5. Fuse box | 6. Turn signal & dimmer switch |
| 7. Turn signal & 4-way relay | 8. Green/yellow | 9. White |
| 10. Yellow | 11. Yellow/blue | 12. Green |
| 13. Black/white | 14. Green/red | 15. Meter pilot light (Right) |
| 16. Meter pilot light (Left) | | |

Fig. 21-7

When the 4-way Switch is "OFF".
Yellow lead (10) is connected to Yellow/blue lead (11).

When the 4-way Switch is "ON".
White lead (9) is connected to Yellow/blue lead (11), and Green lead (12) to both Green/yellow lead (8), and Green/red lead (14).

When the Turn-signal Switch is "ON" for a right turn, green lead (12) is connected to Green/yellow lead (8).

When the Turn-signal Switch is "ON" for a left turn, green lead (12) is connected to Green/red lead (14).

Inspection

(1) Trouble diagnosis

Symptom	Possible cause
1. Lights will not come on in either group.	Fusible link in 30-A fuse is blown off.
2. Hazard light comes on but turn signal lights will not.	Open circuit (due to poor point contact) in turn signal dimmer switch.
3. No light comes on; or lights light up but do not flicker.	Defective relay unit.
4. Turn signal lights are satisfactory, but hazard light will not come on.	Open circuit in hazard warning switch.
5. Flickering frequency is erratic; or lights remain lit.	Light bulbs are defective or improperly grounded.
6. Turning on hazard warning switch lights up only one group of lights.	Defective contact in dimmer switch.

(2) Dimmer switch

Using a circuit tester, check for continuity between each pair of terminals by referring to the chart given in Fig. 21-8, for each position of the dimmer switch lever. Discontinuity means that contact points are burnt or otherwise defective in the switch.

The switch is in sound condition if continuity is noted between terminals 2 and 3, with the lever in right-turn position, and between terminals 1 and 3, with the lever in left-turn position.

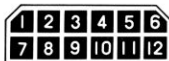

- | | |
|-----------------|----------------|
| 1. Green/red | 7. White |
| 2. Green/yellow | 8. Yellow |
| 3. Green | 9. Yellow/blue |
| 4. Red/green | 10. Blue |
| 5. Red | 11. Black |
| 6. Red/white | 12. Blank |

Fig. 21-8

21-4. Windshield Wiper Motor

Circuit description

The circuit is designed so that, when the Wiper Switch is turned "OFF", the blade will automatically return to the horizontal position. In Fig. 21-9, when the Wiper Switch is turned "ON" while the Main Switch is "ON", current is supplied to the Wiper Motor from the Battery, the motor rotates and the blade moves. The gear mechanism which converts rotational movement of the motor into swinging movement of the blade has a cam on the final gear shaft. The cam switches the contacts of P0 and P2 every revolution. (At the blade stop position, the contact is switched from P2 to P1.)

Repeated contact making and breaking is independent of the wiper motor rotation. When the Wiper Switch is turned "OFF" while the blade is in a position other than the rest position, motor current path is changed (i.e. BI/W → BI → Motor). Therefore, the motor keeps rotating even though the wiper switch is turned "OFF", and the blade will return to the rest position.

When the blade returns to the rest position, the cam contact is changed from P2 to P1 and motor current is shunted. When supply to the motor is cut off, a counter electromotive force is generated in the armature. As a result of this back e.m.f., current flows through the motor and shunt circuit and the motor stops and the wiper blade stays in the specified position.

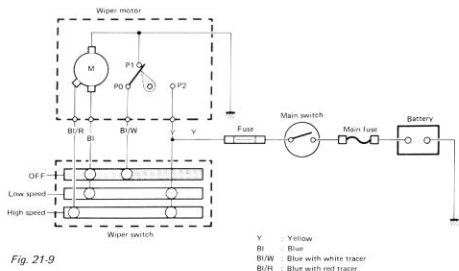

Fig. 21-9

Maintenance

(1) Wiper trouble diagnosis

When the wiper motor does not start even if the Wiper Switch is turned "ON", check lead connections and coupler connections. Then, check the following items.

a) Fuse blown or mounted incorrectly

b) Wiper switch:

To check the wiper switch, remove the couplers and check continuity between the following terminals using a circuit tester.

	Yellow	Blue	Blue/red	Blue/white
High speed	○		○	
Low speed	○	○		
OFF		○		○

Wiper switch

	Black/blue	Black
ON	○	○

Washer switch

c) Break in the wiper motor armature or poor commutator brush contact:

To check these, check continuity between the Blue lead and ground, and the Blue/red wire and ground.

21-5. Fuel Gauge

Circuit description

The fuel gauge for visually telling how full the fuel tank is an electrical instrument comprising a float-actuated potentiometer type of tank unit and a bimetal type indicator (meter) mounted on the instrument panel.

Two bimetal elements are used in the indicating unit, one for deflecting the indicating hand over the "E" to "F" scale and the other (regulator) for on-off control of current.

When fuel level is low in the tank, the float is low and hence a larger ohmic resistance is introduced into the circuit by the potentiometer element in the tank unit. Consequently, a smaller current flows through the windings of the two bimetal elements, so that bimetal deflection is smaller and the indicating hand stays closer to "E" (for empty) side.

The bimetal element of the regulator bimetal draws an additional current. By the total current, the bimetal element deflects to open the circuit and, upon cooling, closes the circuit. In other words, the regulator makes and breaks the circuit intermittently. The average current is fairly constant under varying voltage condition of the battery because a higher battery voltage extends the duration of each contact point separation in the regulator.

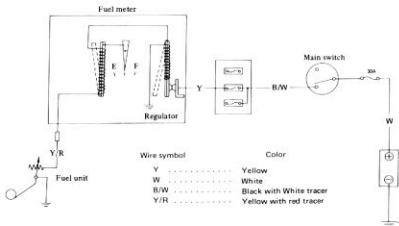

Fig. 21-10

Inspection





The following checks are necessary when the fuel meter indication is false:

- 1 Make sure both the tank unit and fuel tank are properly and securely grounded. If ground connection is loose, current will be small and the indicating hand will be down.
- 2 Make sure that the regulator is properly and securely grounded. If high resistance exists in this ground circuit, the regulator draws but a small current, so that the duration of contact closure is much longer and, consequently, the average current through the other winding will be larger, resulting in a hand deflected closer to "F" position.
- 3 Make sure that the float in the fuel tank is free from interference and without any hitch on its float arm, and that its stopper is correctly positioned.





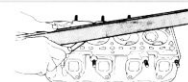

An indicating meter checked to be internally defective must be replaced by a new one.

22. SERVICE DATA & MAINTENANCE SCHEDULE

22-1. Service Data	22-1
22-2. Tightening Torque	22-21
22-3. Periodic Maintenance Schedule	22-35

ITEM				LJ80/81
1	Compression pressure	 <ul style="list-style-type: none"> • Remove all leak plugs. • Install the compression gauge. • Depressure the clutch (to lighten starting load on engine) and depress the accelerator all the way to make the throttle full open. • Crank the engine with the starter motor and read the highest pressure on the compression gauge. 	Standard	13.5 kg/cm ² (192.0 psi) 300 r/min (rpm)
			Service limit	12.0 kg/cm ² (170.0 psi) 300 r/min (rpm)
2	Valve clearance (Intake and Exhaust)		Cold	0.13 – 0.18 mm (0.005 – 0.007 in.)
			Hot	0.23 – 0.28 mm (0.009 – 0.011 in.)
3	Ignition timing		Standard	10° B.T.D.C. below 850 ± 50 r/min (rpm)
4	Engine oil pressure		Standard	3.0 – 4.5 kg/cm ² (42.66 – 63.99 psi) at 3,000 r/min (rpm)
5	Engine idling speed		Standard	850 ± 50 r/min (rpm)
6	Engine vacuum		Standard	40 – 50 cmHg (15.7 – 19.7 in Hg) at 850 r/min (rpm)
7	Flatness of gasket surface		Service limit	0.05 mm (0.002 in.)
				Flatness of manifold seat
	Exhaust	0.1 mm (0.004 in.)		
	Valve seat	Seating width		Intake
Exhaust				1.3 – 1.5 mm (0.0512 – 0.0590 in.)



NOTE: The compression pressure value is measured by using the special tool (compression gauge 09915-64510).

ITEM				LJ80/81		
16	Clutch	Facing wear (Rived head depression)		Standard	1.2 mm (0.05 in.)	
				Service limit	0.5 mm (0.02 in.)	
		Facing & input shaft serration backlash		Service limit	0.5 mm (0.02 in.)	
		Clutch release arm play		Standard	2 - 4 mm (0.08 - 0.16 in.)	
17	Transmission	Clearance between gears and rings		Standard	0.8 - 1.2 mm (0.03 - 0.05 in.)	
				Service limit	0.5 mm (0.02 in.)	
		Key slot width of Synchronizer ring		Standard	9.6 mm (0.38 in.)	
				Service limit	9.9 mm (0.39 in.)	
		Fork shaft locating spring (Free length)		No. 1 spring	Standard	19.5 mm (0.767 in.)
					Service limit	17.0 mm (0.669 in.)
No. 2 spring	Standard			17.5 mm (0.689 in.)		
	Service limit			16.0 mm (0.630 in.)		

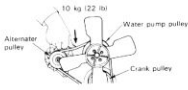

ITEM				LJ80/81		
17	Transmission	Rattle of sliding yoke in extension case bush		Standard	0.02 – 0.06 mm (0.0008 – 0.0024 in.)	
				Service limit	0.1 mm (0.004 in.)	
		Low and second gear backlash		Standard	0.1 mm (0.0039 in.)	
				Service limit	0.3 mm (0.0118 in.)	
		Third and top gear backlash		Standard	0.1 mm (0.0039 in.)	
				Service limit	0.3 mm (0.0118 in.)	
		Reverse gear & Reverse idle gear backlash		Standard	0.1 mm (0.0039 in.)	
				Service limit	0.3 mm (0.0118 in.)	
18	Transfer	Output shaft high gear and low gear backlash		Standard	0.1 mm (0.0039 in.)	
				Service limit	0.3 mm (0.0118 in.)	
		Free length of locating spring		No. 1 spring	Standard	19.5 mm (0.767 in.)
					Service limit	17.0 mm (0.669 in.)
				No. 2 spring	Standard	18.5 mm (0.728 in.)
					Service limit	16.0 mm (0.629 in.)

COOLING SYSTEM

Service data



ITEM				LJ80/81	
19	Fan belt and Thermostat	Fan belt tension as deflection under 10 kg (22 lb) push applied to middle point between pulleys		Standard	10 – 15 mm (0.4 – 0.6 in.)
		Thermostat start-to-open temperature		Standard	82 °C (179 °F)
		Thermostat full-open temperature		Standard	95 °C (203 °F)
		Valve lift		Standard	8 mm (0.31 in.)

DIFFERENTIAL

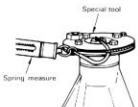
ITEM				LJ80/81	
20	Differential	Side gear backlash		Standard	0.05 – 0.10 mm (0.002 – 0.004 in.)
		Bevel (final) gear backlash		Standard	0.10 – 0.15 mm (0.004 – 0.006 in.)

ITEM				LJ80/81	
20	Differential	Pinion bearing preload		Standard	3.0 – 7.0 kg·cm (2.6 – 6.1 lb·in.)
		Pinion starting torque (with pulley) (Refer to service manual)		Standard	0.6 – 1.4 kg (1.4 – 3.1 lb)



SUSPENSION

ITEM				LJ80/81		
21	Barfield joint, knuckle arm, shockabsorber and spring	Axial play in barfield joint		Standard	0 mm (No play)	
				Service limit	1.5 mm (0.06 in.)	
		Knuckle arm starting torque (force)		Standard	1.0 – 1.8 kg (2.20 – 3.96 lb) Without oil seal	
		Damping force on rebound		Front and rear shock absorbers	Standard	60 kg (132 lb)
		Shock absorbers stroke		Front	Standard	150 mm (5.90 in.)
	Rear		Standard	160 mm (6.30 in.)		

ITEM					LJ80/81
21	Barfield joint, knuckle arm, shock absorber and spring		Front	Standard	940 mm (37 00 in.)
			Rear	Standard	1 000 mm (39 37 in.)
	Spring rate	Front	Standard	4 50 kg/mm (252 lb/in.)	
		Rear	Standard	3 03 kg/mm (169 7 lb/in.) • 3 44 kg/mm (192 6 lb/in.)	

* For LJ81

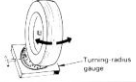
STEERING SYSTEM

ITEM					LJ80/81	
22	Steering gear box and wheel alignment			Standard	15.6	
				Inside	Standard	27°
		Outside		Standard	24°	
		Steering wheel diameter			Standard	400 mm (15 74 in.)
		Minimum turning radius			Standard	4 9 m (16.1 ft) • 5 5 m (18 0 ft)

• For LJ81

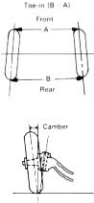
ITEM					LJ80/81	
22	Steering gear box and wheel alignment	Starting torque of worm shaft		Standard	2.0 – 5.0 kg-cm (0.145 – 0.360 lb-ft)	
		Wheel alignment	 <p>Toe-in (B - A) Front A B Rear</p> <p>Camber</p>	Toe-in	Standard	1 – 5 mm (0.04 – 0.20 in.)
				Camber	Standard	1 degree (1°)
				Trail	Standard	11 mm (0.43 in.)
				Kingpin inclination	Standard	9 degrees (9°)
Caster	Standard	2 degrees (2°)				





TIRE

ITEM					LJ80/81	
23	Tire inflating pressure	Tire inflating pressure (not loaded)		Front	Standard	① 120 kPa (17 psi) (1.2 kg/cm ²) ② 140 kPa (20 psi) (1.4 kg/cm ²)
				Rear	Standard	① 160 kPa (23 psi) (1.6 kg/cm ²) ② 220 kPa (32 psi) (2.2 kg/cm ²)
		Tire inflating pressure (loaded)		Front	Standard	140 kPa (20 psi) (1.4 kg/cm ²)
				Rear	Standard	① 200 kPa (29 psi) (2.0 kg/cm ²) ② 220 kPa (32 psi) (2.2 kg/cm ²)

① : For LJ80 and LJ80V ② : For LJ81

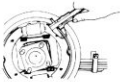

BRAKE



Service data



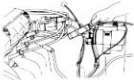

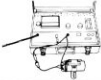
ITEM				LJ80/81	
24	Brake pedal, drum, lining and parking brake	Brake pedal travel		Standard	15 – 20 mm (0.59 – 0.78 in.)
		Pedal arm-to-wall clearance; When pedal is depressed at 30 kg (66 lb)		Standard	50 mm (1.97 in.) minimum
		Brake drum "out-of-round"		Standard	0 mm (0 in.)
				Service limit	0.5 mm (0.02 in.)
		Brake drum inside diameter		Standard	210 mm (8.26 in.)
				Service limit	212 mm (8.34 in.)
		Brake lining thickness (lining + shoe ring)		Standard	6.8 mm (0.27 in.)
Service limit	3.0 mm (0.12 in.)				
Parking brake stroke		Standard	7 notches max.		



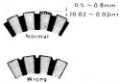
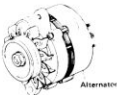

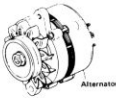

ELECTRICAL

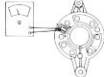

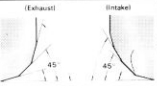
Service data

ITEM				LJ80/81	
25	Ignition system	Ignition timing		Standard	10° B.T.D.C. below 850 ± 50 r/min (rpm)
		Ignition order		Standard	1-3-4-2
		Breaker point gap		Standard	0.4 - 0.5 mm (0.016 - 0.019 in.)
		Cam dwell angle		Standard	52° 
		Condenser capacitance		Standard	0.25 microfarad
		Ignition coil: Primary and secondary winding resistance		Primary	Standard
		Secondary	Standard	About 8 kilo ohms	

ITEM				LJ80/81	
26	Starter motor	Voltage		Standard 12 volts	
		Output		Standard 0.8 KW	
		Rating		Standard 30 seconds	
		Brush length		Standard	16 mm (0.63 in.)
				Service limit	12 mm (0.47 in.)
		Number of pinion teeth		Standard 9	
		Commutator diameter		Standard	32.5 mm (1.28 in.)
Mica undercut		Standard	0.5 - 0.8 mm (0.02 - 0.03 in.)		
		Service limit	0.2 mm (0.007 in.)		
27	Alternator	Nominal operating voltage		Standard 12 volts	
		Maximum alternator output		Standard 35A	
		Effective pulley diameter		Standard 70 mm (2.75 in.)	

ITEM				LJ80/81	
27	Alternator	Maximum permissible alternator speed		Standard	13.000 r/min (rpm)
		Working temperature range		Standard	- 40 – 80 °C (- 104 – 176 °F)
		Rotor; Ring-to-ring circuit resistance		Standard	4 – 5 ohms
		Brush length		Standard	16.5 mm (0.65 in.)
				Service limit	11.0 mm (0.45 in.)
		Standard output voltage and current		Standard	13.8 – 14.8 volts, 20A minimum (When engine speed range of 3,000 – 4,000 r/min)
		Regulated voltage		Standard	13.8 – 14.8 volts for 2,000 – 3,000 engine r/min (rpm)
27	Alternator	Field circuit resistance		Standard	6 – 9 ohms

ITEM				LJ80/81		
7	Cylinder head	Valve seat		Intake and Exhaust	Standard	45°
		Seating angle				
		Cylinder head valve guide hole diameter		Intake and Exhaust	Standard	12 030 – 12 048 mm (0.4736 – 0.4743 in.)
8	Camshaft, valve and valve spring	Camshaft and journal clearance			Standard	0.050 – 0.091 mm (0.0020 – 0.0036 in.)
					Service limit	0.15 mm (0.0059 in.)
		Camshaft thrust clearance			Standard	0.050 – 0.150 mm (0.0020 – 0.0059 in.)
					Service limit	0.30 mm (0.0118 in.)
		Cam height (Base circle + lift)		Intake and Exhaust	Standard	36.152 mm (1.4233 in.)
					Service limit	36.100 mm (1.4212 in.)
				Fuel pump cam	Standard	33.300 mm (1.3110 in.)
					Service limit	33.000 mm (1.2992 in.)
Camshaft deflection			Service limit	0.10 mm (0.0039 in.)		
Valve stem diameter		Intake	Standard	6.965 – 6.980 mm (0.2742 – 0.2748 in.)		
		Exhaust		6.955 – 6.970 mm (0.2738 – 0.2744 in.)		

ITEM					LJ80/81	
28	Alternator regulator	Voltage relay		Armature gap	Standard	Approx. 0.6 mm (0.023 in.)
				Point gap		Approx. 0.4 mm (0.015 in.)
	Voltage regulator		Armature gap	Standard	Approx. 1.1 mm (0.043 in.)	
			Point gap		Approx. 0.5 mm (0.019 in.)	

CAPACITY







ITEM					LJ80/81
29		Cooling solution	Standard		3.8 lit (8.0/6.7 US/Imp pt)
		Fuel tank			40 lit (10.6/8.8 US/Imp gal)
		Engine oil			3.0 lit (6.3/5.3 US/Imp pt)
		Transmission oil			1.0 lit (2.1/1.8 US/Imp pt)
		Transfer oil			0.9 lit (1.9/1.6 US/Imp pt)
		Differential oil			1.3 lit (2.7/2.3 US/Imp pt)

22-2. TIGHTENING TORQUE

ENGINE







Tightening torque

LJ80/81

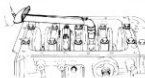



	FASTENING PARTS		N.m (kg·m) lb·ft
1	Cylinder head bolt		55 – 60 (5.5 – 6.0) 40.0 – 43.0
2	Spark plug		20 – 30 (2.0 – 3.0) 14.5 – 21.5
3	Inlet and exhaust manifold nut		18 – 23 (1.8 – 2.3) 13.0 – 16.5
4	Camshaft timing pulley bolt		50 – 60 (5.0 – 6.0) 36.5 – 43.0
5	Valve adjusting nut		15 – 20 (1.5 – 2.0) 11.0 – 14.0
6	Timing belt cover bolt		3 – 4 (0.3 – 0.4) 2.5

ENGINE

Tightening torque

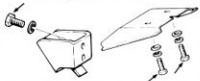
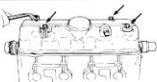

ENGINE			LJ80/81
	FASTENING PARTS		N·m (kg·m) lb·ft
7	Connecting rod bearing cap nut		28 - 32 (2.8 - 3.2) 20.5 - 23.0
8	Crankshaft pulley bolt		50 - 60 (5.0 - 6.0) 36.5 - 43.0
9	Crankshaft bearing cap bolt		43 - 48 (4.3 - 4.8) 31.5 - 34.5
10	Flywheel bolt		40 - 45 (4.0 - 4.5) 29.0 - 32.5
11	Oil pressure unit		12 - 15 (1.2 - 1.5) 9.0 - 10.5
12	Oil filter ass'y		10 - 15 (1.0 - 1.5) 7.5 - 10.5
13	Oil filter stand		20 - 25 (2.0 - 2.5) 14.5 - 18.0

ENGINE



FASTENING PARTS		LJ80/B1
		N.m (kg-m) lb-ft
14	Engine mounting member nut	Nut 10 - 15 (1.0 - 1.5) 7.5 - 10.5
15	Relief valve spring retainer	 15 - 20 (1.5 - 2.0) 11.0 - 14.5
16	Oil pan bolt	 4 - 5 (0.4 - 0.5) 3.0 - 3.5
17	Oil drain plug	 20 - 25 (2.0 - 2.5) 14.5 - 18.0
18	Engine mount bracket bolt	 18 - 23 (1.8 - 2.3) 13.0 - 16.5
19	Cylinder head cover bolt	 3 - 7 (0.3 - 0.7) 2.0 - 5.0
20	Rocker arm shaft screw	 9 - 12 (0.9 - 1.2) 7.0 - 8.5

ENGINE

Tightening torque

			LJ80/81
	FASTENING PARTS		N.m (kg-m) lb-ft
21	Camshaft thrust plate screw		9 – 12 (0.9 – 1.2) 7.0 – 8.5
22	Oil pump gear plate screw		9 – 12 (0.9 – 1.2) 7.0 – 8.5

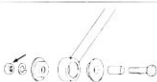
GEARSHIFTING CONTROL

			LJ80/81
	FASTENING PARTS		N.m (kg-m) lb-ft
1	Gearshift control rod joint nut (8 mm nut)		10 – 15 (1.0 – 1.5) 7.5 – 10.5
2	Gearshift control rod front nut (6 mm nut)		6 – 10 (0.6 – 1.0) 4.5 – 7.0
3	Control lever guide plate bolt		4 – 7 (0.4 – 0.7) 3.0 – 5.0

ENGINE

		LJ80/81
	FASTENING PARTS	N m (kg-m) lb-ft
4	Control lever housing bolt	20 - 25 (2.0 - 2.5) 14.5 - 18.0



TRANSMISSION

		LJ80/81
	FASTENING PARTS	N m (kg-m) lb-ft
1	Transmission case bolt	15 - 20 (1.5 - 2.0) 11.0 - 14.5
2	Oil drain plug (1) and level plug (2)	30 - 50 (3.0 - 5.0) 22.0 - 36.0
3	Extension case bolt	15 - 20 (1.5 - 2.0) 11.0 - 14.5
4	Rear mounting bolt and nut	15 - 20 (1.5 - 2.0) 11.0 - 14.5



TRANSMISSION

Tightening torque

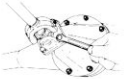
			LJ80/81
	FASTENING PARTS		N m (kg-m) lb-ft
5	Gearshift lever case bolt (8 mm)		9 – 12 (0.9 – 1.2) 7.0 – 8.5
6	Gearshift lever case bolt (6 mm)		4 – 6 (0.4 – 0.6) 3.0 – 4.0
7	Stopper plate for shifter fork shaft		15 – 20 (1.5 – 2.0) 11.0 – 14.5
8	Cross joint flange yoke bolt		15 – 25 (1.5 – 2.5) 11.0 – 18.0

TRANSFER GEAR BOX

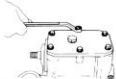
			LJ80/81
	FASTENING PARTS		N m (kg-m) lb-ft
1	Upper – Case cover bolt		9 – 12 (0.9 – 1.2) 7.0 – 8.5

TRANSFER GEAR BOX

		LJ80/81
FASTENING PARTS		N.m (kg-m) lb-ft
2	Lower — Case cover bolt	6 — 10 (0.6 — 1.0) 4.5 — 7.0
3	Transfer front case nut	15 — 20 (1.5 — 2.0) 11.0 — 14.5
4	Shifter fork shaft stopper plate bolt	9 — 12 (0.9 — 1.2) 7.0 — 8.5
5	Oil filler plug and drain plug	30 — 50 (3.0 — 5.0) 22.0 — 36.0
6	Universal joint flange nut	70 — 100 (7.0 — 10.0) 51.0 — 72.0
7	Transfer case mounting nut	15 — 20 (1.5 — 2.0) 11.0 — 14.5
8	Cross joint flange yoke bolt	15 — 25 (1.5 — 2.5) 11.0 — 18.0

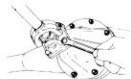





TRANSFER GEAR BOX

Tightening torque



TRANSFER GEAR BOX			LJ80/81
	FASTENING PARTS		N·m (kg·m) lb·ft
9	Transfer case mounting bolt and nut		10 – 15 (1.0 – 1.5) 7.5 – 10.5

DIFFERENTIAL



LJ80/81







DIFFERENTIAL			LJ80/81
	FASTENING PARTS		N·m (kg·m) lb·ft
1	Side bearing cap nut		30 – 37 (3.0 – 3.7) 22.0 – 26.5
2	Drive bevel gear bolt		100 – 110 (10.0 – 11.0) 72.5 – 79.5
3	Differential case bolt		37 – 45 (3.7 – 4.5) 27.0 – 32.5
4	Drive bevel pinion nut		170 – 230 (17.0 – 23.0) 123.0 – 166.0

DIFFERENTIAL





		LJ80/81	
	FASTENING PARTS		N m (kg m) lb-ft
5	Differential carrier nut		15 - 20 (1.5 - 2.0) 11.0 - 14.5
6	Oil filler and oil drain plug		40 - 70 (4.0 - 7.0) 29.0 - 50.5

SUSPENSION

		LJ80/81	
	FASTENING PARTS		N m (kg m) lb-ft
1	Shackle pin nut		30 - 55 (3.0 - 5.5) 22.0 - 39.5
2	Reef spring nut		45 - 70 (4.5 - 7.0) 32.5 - 50.5
3	Reef spring U bolt nut		30 - 45 (3.0 - 4.5) 22.0 - 32.5

ITEM					LJ80/81	
8	Camshaft, valve and valve spring	Valve guide I.D.		Intake and Exhaust	Standard	7 000 – 7 015 mm (0 2755 – 0 2761 in.)
		Valve guide-to-valve stem clearance		Intake	Standard	0 020 – 0 050 mm (0 0008 – 0 0019 in.)
				Exhaust		0 030 – 0 060 mm (0 0012 – 0 0023 in.)
				Intake	Service limit	0 07 mm (0 0027 in.)
				Exhaust		0 09 mm (0 0035 in.)
		Valve stem end deflection		Intake	Service limit	0 12 mm (0 0047 in.)
				Exhaust		0 16 mm (0 0063 in.)
		Valve guide protrusion		Intake and Exhaust	Standard	16 5 mm (0 649 in.)
Valve head radial runout		Intake and Exhaust	Service limit	0 03 mm (0 0012 in.)		
Thickness of valve head periphery		Intake and Exhaust	Standard	0 80 – 1 20 mm (0 0315 – 0 0472 in.)		
		Intake	Service limit	0 6 mm (0 0236 in.)		
		Exhaust		0 7 mm (0 0275 in.)		





SUSPENSION

			LJ80/81
	FASTENING PARTS		N.m (kg-m) lb-ft
4	Wheel nut		(Front and Rear) 50 - 80 (5.0 - 8.0) 36.5 - 57.5
5	Front wheel shaft nut		150 - 270 (15.0 - 27.0) 108.5 - 195.0
6	Rear hub nut		50 - 80 (5.0 - 8.0) 36.5 - 57.5
7	King pin upper and lower bolt		20 - 30 (2.0 - 3.0) 14.5 - 21.5

STEERING

			LJ80/81
	FASTENING PARTS		N.m (kg-m) lb-ft
1	Steering shaft nut		25 - 40 (2.5 - 4.0) 18.0 - 28.5

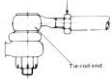
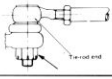

STEERING

STEERING			LJ80/81
	FASTENING PARTS		N m (kg-m) lb-ft
2	Steering rubber joint nut		15 - 25 (1.5 - 2.5) 11.0 - 18.0
3	Steering rubber joint flange bolt		20 - 30 (2.0 - 3.0) 14.5 - 21.5
4	Steering gear box bolt and nut		70 - 90 (7.0 - 9.0) 51.0 - 65.0
5	Steering gear box stay bolt		30 - 55 (3.0 - 5.5) 22.0 - 39.5
6	Steering tie rod (center) lever nut		70 - 90 (7.0 - 9.0) 51.0 - 65.0
7	Tie rod end lock nut		50 - 80 (5.0 - 8.0) 36.5 - 57.5
8	Tie rod end ball stud nut		25 - 55 (2.5 - 5.5) 18.0 - 39.5



STEERING

		LJ80/81	
	FASTENING PARTS		N.m (kg-m) lb-ft
9	Steering column bolt		6 - 9 (0.6 - 0.9) 4.5 - 6.5

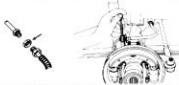
BRAKE



		LJ80/81	
	FASTENING PARTS		N.m (kg-m) lb-ft
1	Brake backing plate bolt and nut		18 - 28 (1.8 - 2.8) 13.0 - 20.0
2	Brake master cylinder bolt or nut		13 - 23 (1.3 - 2.3) 9.5 - 16.5
3	Brake tube union nut		15 - 18 (1.5 - 1.8) 11.0 - 13.0
4	Brake flexible hose nut		20 - 40 (2.0 - 4.0) 14.5 - 28.5

BRAKE

			LJ80/81
	FASTENING PARTS		N.m (kg-m) lb-ft
5	Brake pipe joint bolt		6 - 10 (0.6 - 1.0) 4.5 - 7.0
6	Brake pedal bolt and nut		18 - 28 (1.8 - 2.8) 13.0 - 20.0

For other bolts and nuts not listed above, refer to this chart:

Tightening Torque

Thread diameter (mm)	 					
	N·m	kg·m	lb·ft	N·m	kg·m	lb·ft
4	1.0 – 1.5	0.1 – 0.15	0.7 – 1.0	1.5 – 2.5	0.15 – 0.25	1.0 – 1.8
5	2.0 – 3.0	0.2 – 0.3	1.5 – 2.0	3.0 – 5.0	0.3 – 0.5	2.0 – 3.5
6	4.0 – 6.0	0.4 – 0.6	3.0 – 4.5	6.0 – 9.0	0.6 – 0.9	4.5 – 6.5
8	9.0 – 12.0	0.9 – 1.2	6.5 – 8.5	15.0 – 20.0	1.5 – 2.0	11.0 – 14.5
10	20.0 – 25.0	2.0 – 2.5	14.5 – 18.0	30.0 – 37.0	3.0 – 3.7	21.5 – 27.0
12	35.0 – 40.0	3.5 – 4.0	25.5 – 29.0	50.0 – 65.0	5.0 – 6.5	36.0 – 47.0
14	60.0 – 70.0	6.0 – 7.0	43.5 – 50.5	90.0 – 110.0	9.0 – 11.0	65.0 – 79.5
16	90.0 – 110.0	9.0 – 11.0	65.0 – 79.5	140.0 – 170.0	14.0 – 17.0	101.5 – 123.0
18	140.0 – 160.0	14.0 – 16.0	101.5 – 115.5	210.0 – 250.0	21.0 – 25.0	152.0 – 181.0

22-3. PERIODIC MAINTENANCE

Periodic Maintenance Schedule

Interval: This interval should be judged by odometer reading or months, whichever comes first.	km (x 1,000)	1	10	20	30	40	50	60	70	80
	miles (x 1,000)	1	6	12	18	24	30	36	42	48
	months	1	6	12	18	24	30	36	42	48
ENGINE										
1. Fan (Water pump) drive belt		A	–	I	–	R	–	I	–	R
2. Camshaft timing belt		I	–	I	–	I	–	I	–	I
3. Valve clearance		A	–	A	–	A	–	A	–	A
4. Engine bolts (All cylinder head and manifold fixings)		T	–	T	–	T	–	T	–	T
5. Engine oil filter		R	R	R	R	R	R	R	R	R
6. Engine oil	API Grade SD or SE	R	Replace every 10,000 km (6,000 miles)							
	API Grade SC	R	Replace every 5,000 km (3,000 miles)							
7. Engine coolant		–	–	–	–	R	–	–	–	R
8. Cooling system hoses and connections		–	–	I	–	I	–	I	–	I
9. Exhaust pipes and mountings		–	–	I	–	I	–	I	–	I
IGNITION										
10. Ignition wiring		–	–	I	–	I	–	I	–	I
11. Distributor cap and rotor		–	–	I	–	I	–	I	–	I
12. Spark plugs and distributor breaker point		–	R	R	R	R	R	R	R	R
13. Ignition timing		I	A	A	A	A	A	A	A	A
14. Distributor advance		–	–	I	–	I	–	I	–	I
FUEL										
15. Air cleaner	Paved-road	Clean every 10,000 km (6,000 miles)								
	Dusty condition	Clean every 2,500 km (1,500 miles) or as required								
16. Accelerator cable & Carburetor shafts		–	I&L	I&L	I&L	I&L	I&L	I&L	I&L	I&L
17. Fuel tank cap, gas lines and connections		I	–	–	–	I	–	–	–	I
18. Fuel filter		–	–	–	–	R	–	–	–	R
19. Idle speed and idle mixture		A	–	A	–	A	–	A	–	A

Interval: This interval should be judged by odometer reading or months, whichever comes first.	km (x 1,000)	1	10	20	30	40	50	60	70	80
	miles (x 1,000)	1	6	12	18	24	30	36	42	48
	months	1	6	12	18	24	30	36	42	48
CRANKCASE EMISSION CONTROL										
20. Crankcase ventilation hoses and connections		-	-	I	-	I	-	I	-	I
FUEL EVAPORATIVE EMISSION CONTROL										
21. Fuel vapor storage system, hoses and connections		-	-	I	-	I	-	I	-	I
ELECTRICAL										
22. Wiring harness connections and headlights		-	-	I	-	I	-	I	-	I
CHASSIS AND BODY										
23. Clutch play		I	I	I	I	I	I	I	I	I
24. Brake fluid		I	I	I	I	R	I	I	I	R
25. Brake pedal		I	I	I	I	I	I	I	I	I
26. Brake lever and cable		I	I	I	I	I	I	I	I	I
27. Brake drums and shoes		-	I	I	I	I	I	I	I	I
28. Brake hoses and pipes		-	I	I	I	I	I	I	I	I
29. Tires (Abnormal wear and pressure)		-	I	I	I	I	I	I	I	I
30. Wheels and hub nuts		I	I	I	I	I	I	I	I	I
31. Shock absorbers		-	I	I	I	I	I	I	I	I
32. Propeller shafts		-	-	L	-	L	-	L	-	L
33. Transmission, transfer and differential oil		R	I	I	I	R	I	I	I	R
34. Bolts and nuts		T	-	T	-	T	-	T	-	T
35. Steering condition		I	I	I	I	I	I	I	I	I
36. Test drive		Test drive on completion of each service								

NOTE:

"A": Check and/or adjust if necessary.

"T": Tighten to the specified torque.

"R": Replace or Change.

"L": Lubricate.

"C": Clean.

"I": Inspect and correct or replace if necessary.

LJ81 ('79 Model)

The model LJ81 is different from LJ80 and LJ80V in following respects of servicing and construction.



Fig. 1

Propeller shaft No. 3

(Rear side)

The overall length has been increased, and the outside diameter of the shaft has also been increased.

LJ80 and LJ80V
(Overall length)

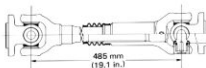

Fig. 2

LJ81
(Overall length)



Fig. 3

Muffler

The tail pipe of LJ81 is longer than those of LJ80 and LJ80V by 270 mm (10.6 in.)

Brake pipe No. 7

The brake pipe No. 7 of LJ81 is longer than those of LJ80 and LJ80V by 270.5 mm (10.7 in.).

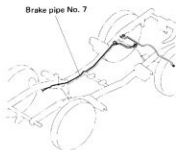

Fig. 4

Rear leaf spring

The leaf-thickness has been increased:

Leaf No.	LJ80 & LJ80V	LJ81
No. 2	5 mm (0.20 in.)	6 mm (0.24 in.)
No. 5	10 mm (0.40 in.)	11 mm (0.43 in.)

With this change the spring constant has also been changed.

	LJ80 & LJ80V	LJ81
Spring-constant	3.03 kg/mm (169.7 lb/in.)	3.44 kg/mm (192.6 lb/in.)

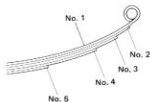

Fig. 5

Rear shock absorber

The upper side mounting has been changed:
(the absorber characteristic remains unchanged.)

LJ80 & LJ80V



Fig. 6

LJ81



Fig. 7

Chassis frame

Three-side gate system has been employed on the LJ81 for easy loading and unloading.



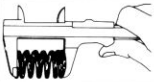





Fig. 8





Specifications



The specifications of LJ81 are different from those of LJ80 in the following items.



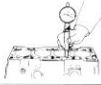
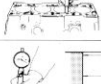
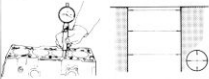

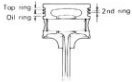
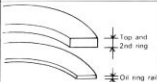

Item	Models	LJ80	LJ81
Overall length		3,195 mm (125.8 in.)	3,620 mm (142.5 in.)
Overall height		1,670 mm (65.7 in.)	1,640 mm (64.6 in.)
Wheelbase		1,930 mm (76.0 in.)	2,200 mm (86.6 in.)
Load deck size:	Length	825 mm (32.5 in.)	1,400 mm (55.1 in.)
	Width	1,205 mm (47.4 in.)	1,315 mm (51.8 in.)
	Height	1,030 mm (40.6 in.)	290 mm (11.4 in.)
Curb weight		770 kg (1,698 lbs) *1	860 kg (1,896 lbs)
Weight distribution,	Front	420 kg (926 lbs) *1	455 kg (1,003 lbs)
	Rear	350 kg (772 lbs) *1	405 kg (893 lbs)
Gross vehicle weight		1,165 kg (2,570 lbs)	1,245 kg (2,745 lbs)
Tire pressure: Front (Unladen)		1.2 kg/cm ² (17 psi)(120kPa)	1.4 kg/cm ² (20 psi)(140 kPa)
	(Laden)	1.4 kg/cm ² (20 psi)(140 kPa)	1.4 kg/cm ² (20 psi)(140 kPa)
Rear (Unladen)		1.6 kg/cm ² (23 psi)(160 kPa)	2.2 kg/cm ² (32 psi)(220 kPa)
	(Laden)	2.0 kg/cm ² (29 psi)(200 kPa)	2.2 kg/cm ² (32 psi)(220 kPa)
Turning radius		4.9 m (16.1 ft.)	5.5 m (18.0 ft.)

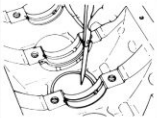

*1 : For canvas door type

ITEM				LJ80/81	
8	Camshaft, valve and valve spring		Intake	Standard	1.3 – 1.5 mm (0.0512 – 0.0590 in.)
			Exhaust		1.3 – 1.5 mm (0.0512 – 0.0590 in.)
			Intake and Exhaust	Standard	47.7 mm (1.8779 in.)
				Service limit	46.5 mm (1.8307 in.)
			Intake and Exhaust	Standard	26 – 30 kg (57.3 – 66.1 lb) for fitting length 40 mm (1.57 in.)
Service limit	24 kg (52.9 lb) for fitting length 40 mm (1.57 in.)				
		Service limit	2.0 mm (0.079 in.)		
9	Rocker arm shaft and rocker arm			Standard	14.965 – 14.980 mm (0.589 – 0.590 in.)
				Standard	14.985 – 15.005 mm (0.590 – 0.591 in.)
	Shaft-to-arm clearance	Intake and Exhaust	Standard	0.005 – 0.040 mm (0.0002 – 0.0016 in.)	
		Intake and Exhaust	Service limit	0.07 mm (0.0027 in.)	

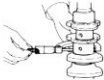
ITEM				LJ80/81	
9	Rocker arm shaft and rocker arm Rocker shaft deflection		Service limit	0.06 mm (0.0023 in.)	
10	Cylinder	Flatness of gasketed surface		Service limit	0.05 mm (0.0020 in.)
		Cylinder bore		Standard	62.005 – 62.020 mm (2.4411 – 2.4417 in.)
		Difference in bore between cylinders		Service limit	0.05 mm (0.0020 in.)
		Wear limit on bore		Service limit	0.05 mm (0.0020 in.)
		Cylinder-to-piston clearance		Standard	0.040 – 0.050 mm (0.0016 – 0.0020 in.)
11	Piston		Standard	61.960 – 61.975 mm (2.4393 – 2.4399 in.)	
			Standard	62.210 – 62.225 mm (2.4492 – 2.4498 in.)	
			Standard	62.460 – 62.475 mm (2.4590 – 2.4596 in.)	
	Piston pin diameter		Standard	15.995 – 16.000 mm (0.6297 – 0.6299 in.)	

ITEM					LJ80/81
11	Piston	Piston pin clearance in con. rod		Standard	0.003 – 0.016 mm (0.0001 – 0.0006 in.)
				Service limit	0.05 mm (0.0020 in.)
	Piston ring groove width		Top ring	Standard	1.52 – 1.54 mm (0.0598 – 0.0606 in.)
			2nd ring	Standard	1.51 – 1.53 mm (0.0594 – 0.0602 in.)
			Oil ring	Standard	2.81 – 2.83 mm (0.1106 – 0.1114 in.)
12	Piston ring thickness		Top ring and 2nd ring	Standard	1.47 – 1.49 mm (0.0578 – 0.0586 in.)
			Oil ring	Standard	0.45 mm (0.0177 in.)
	Ring clearance in groove		Top ring	Standard	0.03 – 0.07 mm (0.0012 – 0.0027 in.)
				Service limit	0.12 mm (0.0047 in.)
			2nd ring	Standard	0.02 – 0.06 mm (0.0008 – 0.0023 in.)
				Service limit	0.10 mm (0.0039 in.)
	Piston ring end gap		Top and 2nd ring	Standard	0.15 – 0.35 mm (0.0059 – 0.0137 in.)
Service limit				0.7 mm (0.0275 in.)	
Oil ring			Standard	0.30 – 0.90 mm (0.0118 – 0.0354 in.)	
			Service limit	1.8 mm (0.0708 in.)	

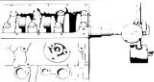
ITEM					LJ80/81	
12	Piston ring	Piston ring free end gap		Top ring	Standard	6.5 mm (0.2559 in.)
				2nd ring	Standard	8.5 mm (0.3346 in.)
13	Crankshaft	Crankshaft deflection (middle)		Service limit		0.06 mm (0.0023 in.)
		Crank pin diameter		Standard		37.985 – 38.000 mm (1.4954 – 1.4960 in.)
		Crank pin clearance in con. rod		Standard		0.020 – 0.040 mm (0.0008 – 0.0016 in.)
				Service limit		0.08 mm (0.0031 in.)
		Connecting rod small end bore		Standard		16.003 – 16.011 mm (0.6300 – 0.6303 in.)
		Crank journal diameter		Standard		49.985 – 50.000 mm (1.9679 – 1.9685 in.)
		Bearing-to-journal clearance		Standard		0.020 – 0.040 mm (0.0008 – 0.0016 in.)
Service limit				0.08 mm (0.0031 in.)		





ITEM					LJ80/81
13	Crankshaft	Crankshaft thrust play		Standard	0.130 – 0.280 mm (0.0051 – 0.0110 in.)
				Service limit	0.35 mm (0.0138 in.)
		Connecting rod big end thrust clearance		Standard	0.10 – 0.20 mm (0.0039 – 0.0078 in.)
				Service limit	0.30 mm (0.0118 in.)
	Connecting rod		Twist	Service limit	0.10 mm (0.0039 in.)
			Straightness	Service limit	0.05 mm (0.0020 in.)

FUEL SYSTEM

ITEM					LJ80/81
14	Fuel pump	Discharge pressure		Standard	0.25 – 0.35 kg/cm ² (3.55 – 4.97 psi)
		Pump capacity		Standard	1.3 liters/minute or better at 2,000 r/min (rpm)

LUBRICATION

ITEM					LJ80/81
15	Oil pump	Outer gear periphery clearance in pump case		Standard	0.12 – 0.20 mm (0.0047 – 0.0078 in.)
				Service limit	0.30 mm (0.0118 in.)

ITEM				LJ80/81	
15	Oil pump	Outer gear tooth clearance in pump case		Standard	0.25 – 0.40 mm (0.0098 – 0.0157 in.)
		Inner gear tooth clearance in pump case		Standard	0.60 – 0.80 mm (0.0236 – 0.0315 in.)
		Oil pump side clearance (flatness)		Standard	0.045 – 0.120 mm (0.0018 – 0.0047 in.)
				Service limit	0.17 mm (0.0067 in.)
		Oil relief valve spring		Free length	Standard
10 mm (0.39 in.) compressive force	Standard			1.49 kg (3.280 lb)	
	Service limit			1.200 kg (2.645 lb)	
Set pressure of oil pressure switch			Standard	0.2 – 0.4 kg/cm ² (2.84 – 5.68 psi)	

CLUTCH, TRANSMISSION AND TRANSFER

ITEM				LJ80/81	
16	Clutch	Pedal play		Standard	15 – 25 mm (0.6 – 1.0 in.)

Modifications have been carried out on inspection, replacement, adjustment and cleaning procedures contained in the previous pages. The modified procedures are described from this page to p.23-12. These new procedures should be employed for all the models of LJ80, 80V and 81.

CAMSHAFT TIMING BELT

NOTE:

Method of adjustment on p.81 of this book is applicable to the car with a body number up to 113438 for LJ80/80V and 106805 for LJ81.

As to the car with a body number after that, perform replacement and adjustment according to the following.

1. Replacement

- 1) To bring the piston of No. 1 cylinder to TDC, align the mark "T" on flywheel with the timing mark on the transmission case by turning the crankshaft, and then be sure that the five reference points line up straight: a) the marks punched on the camshaft pulley, b) arrow marks on the belt case, c) the keyway in the crankshaft timing belt pulley.

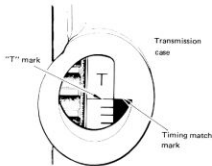

Fig. 23-1

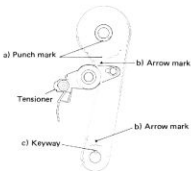

Fig. 23-2

- 2) Remove a part of the tensioner spring from tensioner bracket as shown Fig. 23-3 and loosen the bolt and the nut securing the tensioner, and then remove the camshaft timing belt.

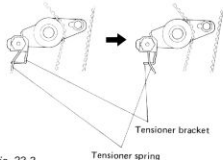

Fig. 23-3

- 3) Install the new camshaft timing belt, and tense it to specified range according to the adjustment procedure.

2. Adjustment

- 1) Remove the cylinder head cover, and loosen all the valve clearance adjusting screws after loosening each lock nut, so that the camshaft and the pulley can rotate freely.
- 2) Hook the spring on the bracket as shown in Fig. 23-4 so that the timing belt can be tensed to specified range by the tensioner spring force.

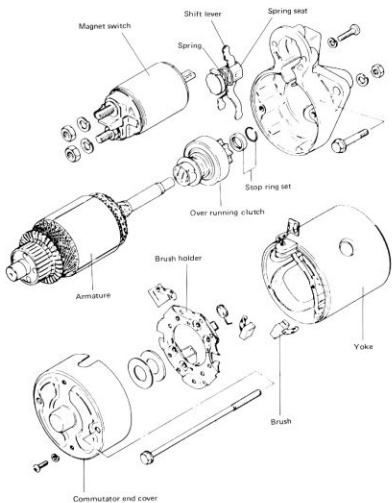

Fig. 23-28

TRANSFER INPUT SHAFT BEARING RETAINER SHIM

NOTE:

The following is applicable to the car with a body number after 111401 for LJ80/80V and 106075 for LJ81.

When reassembling the disassembled transfer input shaft or retainer, it is required to adjust the thrust clearance of the transfer input shaft. This adjustment is done by increasing or decreasing the number of shims between the retainer (2) and the bearing (4). Method of adjustment is given in this section.

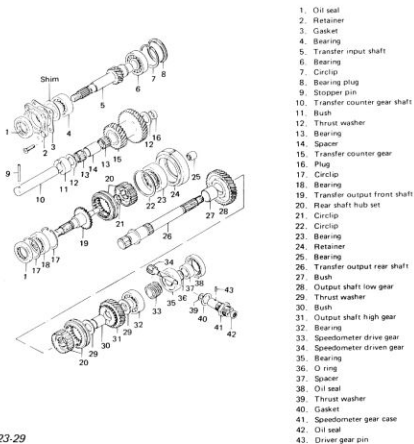

Fig. 23-29

Input shaft bearing retainer

When installing the input shaft bearing retainer in the transfer case, it is required to adjust input shaft thrust clearance. Check in the following way if thrust clearance is within the range given below.

- 1) Measure the distance "A" when input shaft ① and bearings are correctly installed in the transfer case.

NOTE:

When measuring, remove the gasket and the shim if provided.

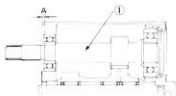

A: Distance between the transfer case end surface and the bearing outside end surface.

Fig. 23-30

- 2) Measure the length "B" of the bearing retainer.

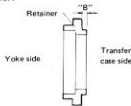

B : Length of the retainer boss portion

Fig. 23-31

- 3) "A" + 0.5 - "B" = Clearance
* 0.5 is gasket thickness (mm)

Input shaft thrust clearance specification	Standard
	0.1 ~ 0.2 mm (0.004 ~ 0.008 in)

If measurement shows that the clearance exceeds the above standard value, increase the thickness of shims.

Example:

In case that the above measurements show that A = 3.5 mm and B = 3.0 mm,
 $3.5 \text{ mm} + 0.5 \text{ mm} - 3.0 \text{ mm} = 1.0 \text{ mm}$
 (clearance)
 $1.0 \text{ mm} - (0.1 \sim 0.2 \text{ mm}) = 0.8 \sim 0.9 \text{ mm}$
 Thus 0.8 ~ 0.9 mm is the thickness of shims required for adjustment.

Size of shims for input shaft	0.2, 0.5 mm (0.008 ~ 0.020 in)
-------------------------------	-----------------------------------

The thickness of the shim is increased or decreased between retainer ② and bearing ③.

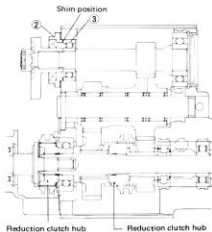

Fig. 23-32

SPECIFICATIONS

NOTE:

From this page of specification to p.23-17, the main items modified for 1980 models from 1979 models are described.

Models		LJ80	LJ80V	LJ81
Item				
DIMENSIONS				
Overall length		3,275 mm (128.9 in.)	←	3,630 mm (142.9 in.)
Overall width		1,415 mm (55.7 in.)	←	←
Overall height		1,685 mm (66.3 in.)	1,675 mm (65.9 in.)	1,640 mm (64.6 in.)
Wheelbase		1,930 mm (76.0 in.)	←	2,200 mm (86.6 in.)
Tread	front	1,190 mm (46.9 in.)	←	←
	rear	1,200 mm (47.2 in.)	←	←
Load deck size	length	825 mm (32.5 in.)	785 mm (30.9 in.)	1,400 mm (55.1 in.)
	width	1,205 mm (47.4 in.)	1,190 mm (46.9 in.)	1,315 mm (51.8 in.)
	height	1,030 mm (40.6 in.)	1,045 mm (41.1 in.)	290 mm (11.4 in.)
Ground clearance		210 mm (8.3 in.)	←	195 mm (7.7 in.)
WEIGHT				
Curb weight		790 kg (1,742 lbs) *1	840 kg (1,852 lbs)	865 kg (1,907 lbs)
		810 kg (1,786 lbs) *2		
Weight distribution	front	430 kg (948 lbs) *1	445 kg (981 lbs)	455 kg (1,003 lbs)
		445 kg (981 lbs) *2		
	rear	360 kg (794 lbs) *1	395 kg (871 lbs)	410 kg (904 lbs)
		365 kg (805 lbs) *2		
Gross vehicle weight		1,185 kg (2,612 lbs)	←	1,250 kg (2,756 lbs)
Seating capacity		2-persons	←	←
Maximum loading capacity		250 kg (551 lbs)	200 kg (441 lbs)	250 kg (551 lbs)
ENGINE				
Type		Four-stroke cycle, water-cooled, OHC	←	←
Number of cylinders		4	←	←
Lubrication system		Wet sump	←	←
Bore		62.0 mm (2.441 in.)	←	←
Stroke		66.0 mm (2.598 in.)	←	←
Piston displacement		797 cm ³ (797 cc, 48.6 cu.in)	←	←
Compression ratio		8.7 : 1	←	←
Carburetor		MIKUNI 32 PHD, Single	←	←
Air cleaner		Polyurethane foam element	←	←

*1 Canvas door type

*2 Panel door type

Models		LJ80	LJ80V	LJ81
Item				
ELECTRICAL				
Ignition timing		10° B.T.D.C. below 850 r/min (rpm)	→	→
Standard spark plug		NGK BPR-5ES or NIPPON DENSO W16EXR-U	→	→
Starter		Magnetic shift type	→	→
Generator		Alternator	→	→
Battery		12V, 162 kC (45 Ah)/20HR	→	→
Headlight		12V, 50/40W	→	→
Turn signal light		12V, 23W (32 cp)	→	→
Combination light		12V, 8W (3 cp)	→	→
Tail/Brake light		12V, 8/23W (3/32 cp)	→	→
Side turn signal light		12V, 8W	→	→
License plate light		12V, 10W (4 cp)	→	→
Back-up light		12V, 27W	→	→
Interior light		12V, 5W	→	→
Brake system warning light		12V, 3.4W	→	→
Seat belt indicator light		12V, 3.4W	→	→
Meter pilot light		12V, 3.4W	→	→
Main fuse		30A	→	→
Fuse box		10/15/20A	→	→
POWER TRANSMISSION				
Clutch type		Dry, single disc	→	→
Transmission type		4 forward all synchromesh, 1 reverse	→	→
Transfer gear box type		2-speed constantmesh	→	→
Final reduction ratio		4.556	→	→
Gear ratios	low	3.835	→	→
	2nd	2.359	→	→
	3rd	1.543	→	→
	top	1.000	→	→
	reverse	4.026	→	→
Transfer gear ratios	low range	3.013	→	2.571
	high range	1.714	→	1.563

Models		LJ80	LJ80V	LJ81
Item				
Overall reduction ratios:				
Low range	low	52.643	—	44.924
	2nd	32.382	—	27.635
	3rd	21.181	—	18.073
	top	13.727	—	11.715
	reverse	55.265	—	47.170
High range	low	29.947	—	27.297
	2nd	18.421	—	16.792
	3rd	12.049	—	10.982
	top	7.808	—	7.119
	reverse	31.438	—	28.662
WHEEL AND SUSPENSION				
Tire size: front and rear		FR78-15 (5% - JJx15)	—	165 SR 15
Tire pressure	front	120 kPa (1.20 kg/cm ² , 17 psi)	—	140 kPa (1.4 kg/cm ²)
	rear	120 kPa (1.20 kg/cm ² , 17 psi) - unladen	—	220 kPa (2.20 kg/cm ² , 32 psi)
		180 kPa (1.80 kg/cm ² , 26 psi) - laden	—	
Suspension type	front	Leaf spring	—	—
	rear	Leaf spring	—	—
STEERING				
Turning radius		4.9 m (16.1 ft)	—	5.5 m (18.0 ft)
Steering gear box		Ball nut	—	—
Toe-in		1–5 mm (0.04 – 0.20 in.)	—	—
Camber angle		1°00'	—	—
Caster angle		2°00'	—	—
Trail		10 mm (0.39 in.)	—	—
King pin angle		9°00'	—	—
BRAKE SYSTEM				
Type		4-wheel, hydraulic	—	—
Wheel brake	front	Two-leading	—	—
	rear	Leading and trailing	—	—
Parking brake		Internal expanding, on propeller shaft	—	—
CAPACITIES				
Cooling solution		3.8 ℓ (8.0 US pt)	—	—
Fuel tank		40 ℓ (10.6 US gal)	—	—
Engine oil		3.0 ℓ (6.3 US pt)	—	—
Transmission oil		1.0 ℓ (2.1 US pt)	—	—
Differential gear box oil		1.3 ℓ (2.7 US pt)	—	—
Transfer gear box oil		0.9 ℓ (1.9 US pt)	—	—

Tire

LJ80/LJ80V	'80 Model	'79 Model
	FR78-15	165SR15
	Tubeless type	Tube type

LJ81	'80 Model	'79 Model
	165 SR15	
	Tubeless type	Tube type

FR78-15 tire air pressure specification

	Non-load condition	Loaded condition
Front wheel tires	1.2 kg/cm ² (17 psi)(120 kPa)	1.2 kg/cm ² (17 psi)(120 kPa)
Rear wheel tires	1.2 kg/cm ² (17 psi)(120 kPa)	1.8 kg/cm ² (26 psi)(180 kPa)

165SR15 ('80 Models) tire air pressure specification

	Non-load condition	Loaded condition
Front wheel tires	1.4 kg/cm ² (20 psi)(140 kPa)	1.4 kg/cm ² (20 psi)(140 kPa)
Rear wheel tires	2.2 kg/cm ² (32 psi)(220 kPa)	2.2 kg/cm ² (32 psi)(220 kPa)

Tire service (wear) limit

FR78-15 tire	165SR15 ('80 Models)
Less than 1.6 mm (0.063 in) depth of tread at two places.	

Wheel rim

LJ80/80V/81	'80 Model	'79 Model
	5½-JJ x 15	4.50E x 15

Tightening torque for wheel hub nuts	50 – 80 N.m 5.0 – 8.0 kg-m (36.5 – 57.5 lb-ft)
---	--

Steering gear box

Although the component parts within the gear box are the same as those of '79 model, its case shape has been transformed. As a result, measurement of oil level should be as follows.

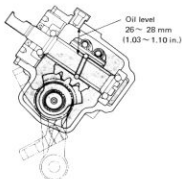

NOTE:

Measurements of the steering gear box other than that of oil level are the same as those of '79 model.

Transfer gear box

The gear ratio in the transfer gear box of the car with FR78-15 tires mounted has been modified as follows.

Model LJ80, LJ80V

Shift position		Rear-wheel drive	All-wheel drive high	All-wheel drive low
Primary gear ratio (Reduction ratio)		29/14 (2.071)		
Secondary ratios	Gear	24/29	24/29	32/22
	Reduction	0.828	0.828	1.455
Overall transfer reduction ratio		1.714	1.714	3.013

In accordance with the above modification, the speed meter drive and driven gears have also been modified.

NOTE:

The gear ratio of LJ81 remains the same as that of '79 model.

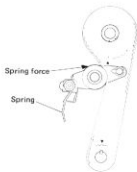

Fig. 23-4

Now rotate the crankshaft clockwise fully twice. And then tighten the bolt and the nut of the timing belt tensioner to the torque specified below. Make sure to tighten the bolt first and then the nut.

NOTE:

Whenever tightening a bolt securing the tensioner, apply **THREAD LOCK CEMENT SUPER 1342** (Part No. 99000-32050) to the screw part of the bolt.

Tightening torque for tensioner bolt and nut	N.m	kg-m	lb-ft
	15 ~ 23	1.5 ~ 2.3	11.0 ~ 16.5

- 3) After retightening the bolt and the nut, check to be sure that the tension is within the specified range when pushing the belt at the mid point between camshaft and crankshaft.

Timing belt tension "L"	5.5 ~ 6.5 mm (0.22 ~ 0.26 in.)
-------------------------	-----------------------------------

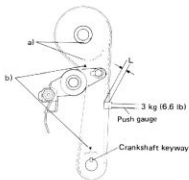

Fig. 23-5

After adjusting the belt tension within specified range, adjust each valve clearance to specified value.

CAUTION:

After adjusting the belt tension, turn the crankshaft clockwise by two complete rotations and check again if marks a), b) and the crankshaft keyway line up straight. If not, the replacement procedure must be repeated.

WARNING:

All adjustments noted above are to be performed with the **ENGINE NOT RUNNING**.

AIR CLEANER

NOTE:

As to the car with a body number after 118340 for LJ80/80V and 107903 for LJ81, clean the air cleaner element according to the following procedure.

Clean	Paved road: Every 10,000 km (6,000 miles)
	Dusty condition: Every 2,500 km (1,500 miles) or as required
Replace	Every 40,000 km (24,000 miles) NOTE: More frequent replacement if under dusty driving conditions.

This air cleaner element is of dry type. Remember that it needs cleaning according to the following method and interval:

- 1) Take out the cleaner element ① off the air cleaner case.

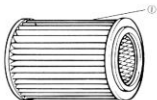

Fig. 23-6

- 2) Blow off dust by compressed air from inside of element.

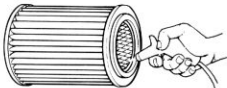

Fig. 23-7

NOTE:

If the element are heavily dirtied, wash it in household type detergent. After washing, rinse the detergent out of element, and dry it completely.

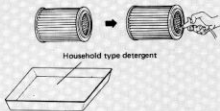

Fig. 23-8

STARTING MOTOR

NOTE:

The starting motor installed in the car with the following body number is made by MITSUBISHI.

LJ80/80V..... on and after 110608

LJ81 on and after 106405

Perform disassembly, assembly and inspection of this starting motor according to the following procedures.

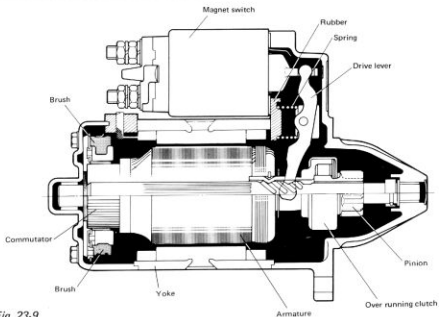

Fig. 23-9

Specifications

Voltage	12 volts
Output	0.7 kW
Rating	30 seconds
Direction of rotation	Clockwise as viewed from pinion side
Brush length	17 mm (0.67 in.)
Number of pinion teeth	8
No-load characteristic	53 A maximum at 11.5 volts, 6,800 rpm minimum
Load characteristic	150 A maximum at 9 volts and 0.28 kg-m torque, 1,850 rpm minimum
Locked rotor current	340 A maximum at 5 volts, 0.72 kg-m minimum
Magnetic switch operating voltage	8 volts maximum

Disassembly

NOTE:

Before disassembling the starter motor, be sure to put match marks on the mating surfaces of the following parts (A and B) as shown in the figure below so that any possible mistakes can be avoided.

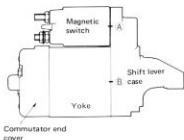

Fig. 23-10

- 1) Remove the nut securing the end of the field coil lead to the terminal on the head of magnetic switch.
- 2) Take off the magnetic switch ① from the starter motor body by removing the two mounting screws.

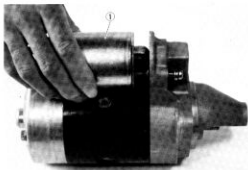

Fig. 23-11

- 3) Loosen 2 bolts and 2 screws to remove the commutator end cover.

- 4) From the yoke, separate the shift lever case and armature.



Fig. 23-12

- 5) Draw brushes out of the holder.



Fig. 23-13

- 6) Draw off the over running clutch, as follows:
(1) Draw stop ring ① toward the clutch side.
(2) Remove snap ring ② and slide off clutch.

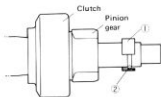

Fig. 23-14

Maintenance Services

In the event the starter motor is found unable to crank the engine, the first thing to be checked is whether the drive pinion plunges out. If the pinion does not plunge out, then the magnetic switch must be checked.

If the pinion plunges out satisfactorily, then the inability of the motor to crank the engine is likely to be due to some defective condition in the commutator or in the armature, provided that the battery is in good condition and that the circuit for applying the battery voltage to the motor is free from any open or fault. Having narrowed the scope of search for the cause of trouble to the motor proper, proceed as follows:

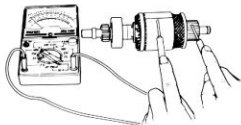

Fig. 23-16

- Again using the tester, check for continuity between each pair of adjacent commutator segments. If discontinuity is noted at any part of the commutator, replace the whole sub-assembly of the armature.

Checking the field coils

Check to be sure that the field circuit is neither grounded or open-circuited. This can be effected by using a circuit tester as shown. If continuity is indicated by the tester hooked to the housing or frame, it means that the insulation has failed, resulting in a grounded field coil. Such a fault can be corrected by repair in most cases.

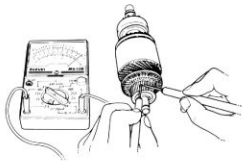

Fig. 23-17

Servicing the commutator

- If the surface of the commutator is gummy or otherwise dirty, wipe it off with a cloth dampened with gasoline. If the surface is coarsened or in burnt condition, smoothen it by grinding with sandpaper. If the surface is grooved deep, it may be necessary to remove the groove marks by turning the commutator in a lathe; such turning is often successful in reconditioning the commutator if the extra stock necessary for removal by cutting is available without reducing its diameter to the limit.

Commutator diameter	Standard 38.7 mm (1.52 in.)
---------------------	--------------------------------

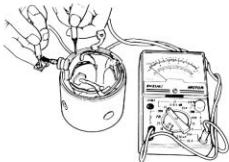

Fig. 23-15

Checking the armature

- Using the circuit tester, see if there is any continuity between commutator and armature core. The tester will indicate infinite resistance if the insulation is in sound condition.

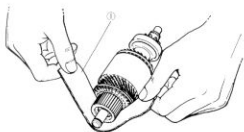

Fig. 23-18 ① Sandpaper

- Make sure that the mica between each pair of adjacent segments is undercut to the prescribed depth. The conventional undercutting technique is to be used in repairing the commutator.

Mica undercut	Standard	Service limit
	0.4 ~ 0.6 mm (0.015 ~ 0.023 in.)	0.2 mm (0.007 in.)

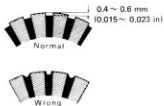

Fig. 23-19

Testing the magnetic switch

Before separating the magnetic switch from the motor proper just removed from the crankcase, test the switch by connecting the battery to the switch, as shown, to see if the drive pinion jumps out when the battery voltage is applied. (With the positive terminal of the battery cable end.) With the switch coils in sound condition, the drive pinion will jump out and, even when the main circuit is opened at "A", will remain in "jumped out" position. If undoing the connection at "A" causes the drive pinion to retract, it means that the holding coil is defective.

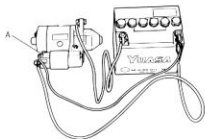

Fig. 23-20

Servicing the brushes

Check the length of each brush. If brushes are worn down to the service limit, replace them.

Brush length	Standard	Service limit
	17 mm (0.67 in.)	11.5 mm (0.45 in.)



Fig. 23-21

Servicing the brush holders

Make sure that the insulation between the two brush holders, positive and negative, is in good condition. This should be verified with the use of the circuit tester. If any continuity is noted, repair the insulation.

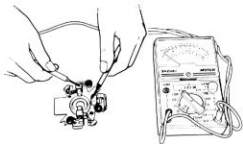

Fig. 23-22

Important Reminders for Starter Motor Reassembly

Various parts of the starter motor assembly need lubrication at each overhaul. The lubrication points are illustrated below:

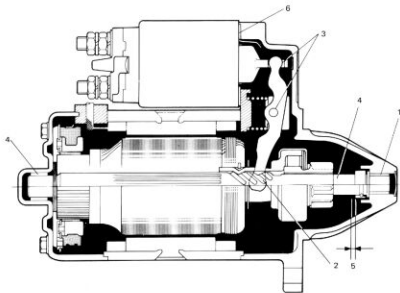

Fig. 23-23

- 1) Give grease to the bush in the drive housing.
- 2) Grease the helical splines before mounting the clutch sub-assembly.
- 3) Grease the sliding or contacting surfaces associated with shift lever.
- 4) Grease the bush fitted into the end frame and also the armature shaft end inserted into this bush.
- 5) The pinion gap "5" can be adjusted by means of the magnetic switch packing. Adjust the gap with in 0.2 ~ 0.5 mm(0.008 ~ 0.020 in) by means of increasing or decreasing the switch packing "6".

Shift lever

When installing lever ① in the shift lever case, be careful of its installing direction referring to Fig. 23-24.

Install shift lever spring seat ② with its stepped part directed toward the spring side.

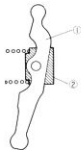

Fig. 23-24

Armature

When installing the armature in the shift lever case, align shift lever ① with shift lever groove ③ on the clutch side.

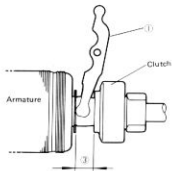

Fig. 23-25

Yoke

When installing the yoke on the shift lever case, be sure to match their match marks ⑧ marked when disassembling.



Fig. 23-26

Starter magnetic switch

When installing the magnetic switch on the lever case, be sure to match their match marks ⑨ marked when disassembling.

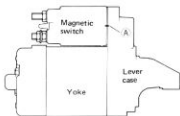

Fig. 23-27