

SUZUKI

LJ20

LJ20V

OWNER'S MANUAL



FORWARD

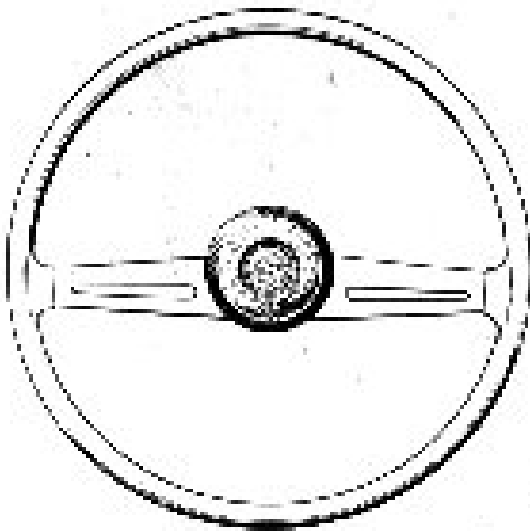

Congratulations

You are now the owner of the Suzuki LJ20 or LJ20V, a sensational mini-car from Japan.

Suzuki LJ20 and LJ20V are unique cars which run not only town street but also rough road, for example sands and mountains etc., and gives play to motive power at such places.

We are pleased to present you this manual as a guide to daily care and maintenance of the Suzuki LJ20 and LJ20V. For further information, please contact your Suzuki dealer.

IDENTIFICATION DATA

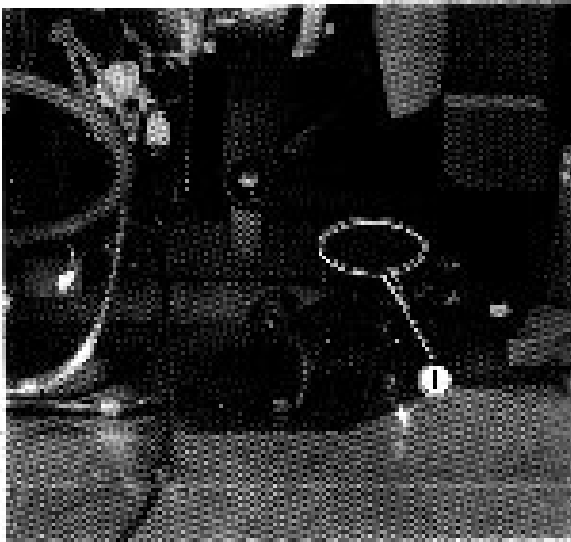

① Chassis type and number

② Identification plate: Chassis type, engine type, Weight and Piston displacement

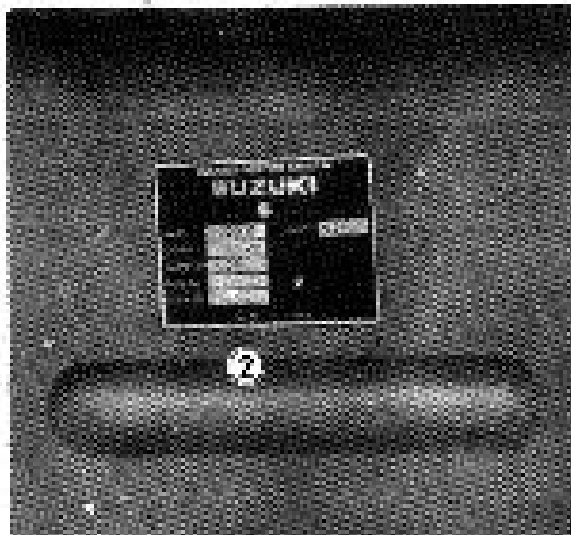

③ Engine type and number

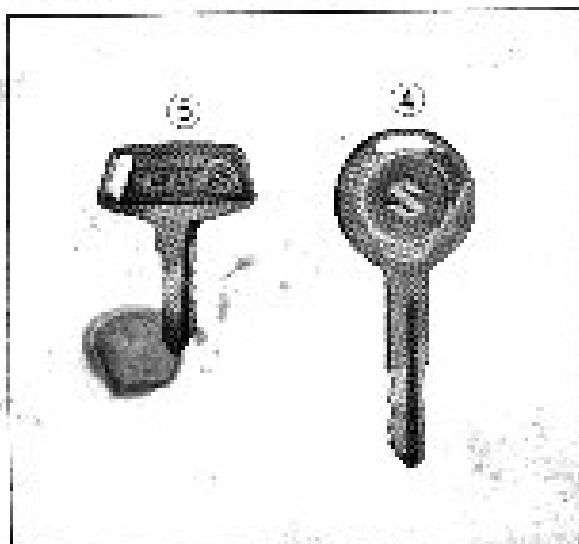
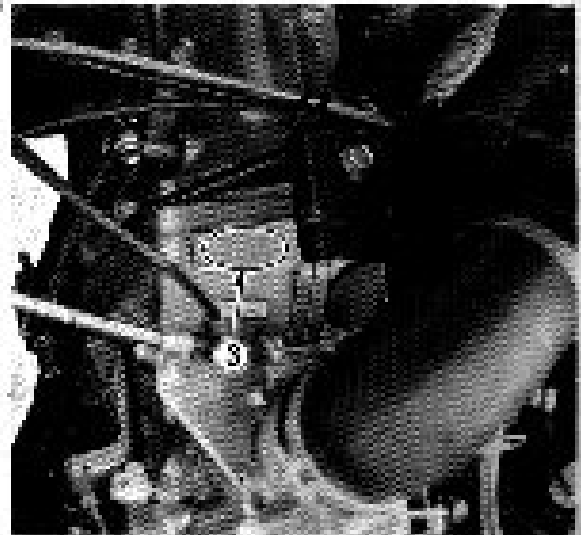

④ Ignition switch key

⑤ Parking brake lever lock key (LJ20)

SUZUKI CCI LUBRICATION SYSTEM

The Suzuki CCI system as used in the LJ20 and LJ20V is one of the world's most advanced lubrication systems for the two-cycle engine.

This system has been developed by many years of experience in the two-cycle field and has reached its present high level of dependability due to a program of continuous refinement and testing. In the CCI lubrication system, the oil is stored in a separate tank and a fresh charge of oil is fed by the oil pump to the crankshaft bearings, connecting rod big and small end bearings, the piston surface and the cylinder wall.

The amount of oil fed to these areas is regulated by the oil pump control lever which is controlled by engine speed and the amount of throttle opening.

Since the engine is constantly lubricated by a fresh charge of oil which is properly regulated to meet all operating conditions, the CCI system assures that proper lubrication for high performance and clean engine operation is always maintained.

This results in less carbon build-up and less exhaust smoking than was previously possible when troublesome pre-mixing of gasoline and oil was necessary.

CONTROLS

Location of parts

(LJ20)

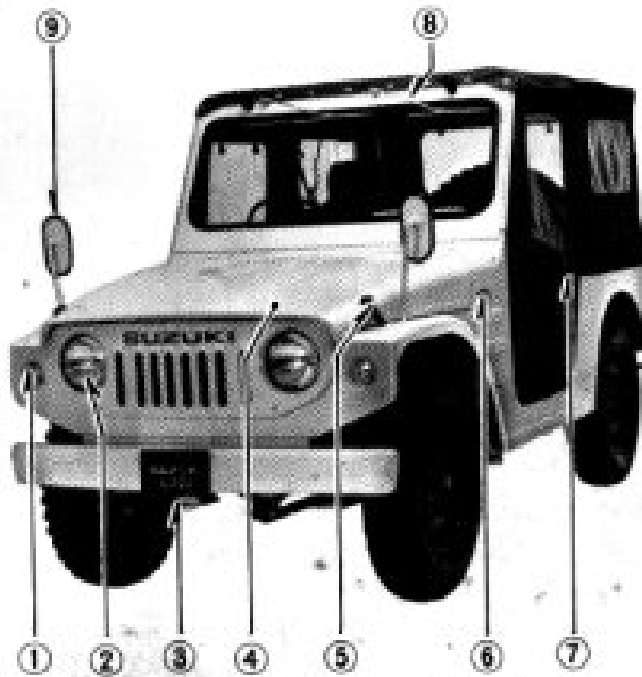

- ① Front turn signal lamp
- ② Head lamp
- ③ Front towing hook
- ④ Engine hood
- ⑤ Engine hood hook shaped grip
- ⑥ Side turn signal lamp
- ⑦ Canvas door handle
- ⑧ Windshield wiper
- ⑨ Rear view mirror

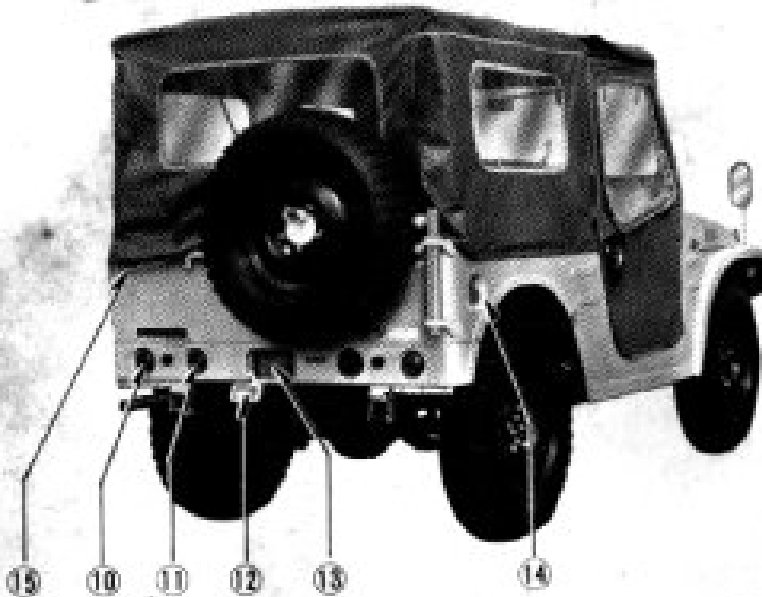

- ⑩ Rear turn signal/tail/parking lamp
- ⑪ Brake lamp
- ⑫ Back up lamp
- ⑬ Rear towing hook
- ⑭ Fuel tank cap
- ⑮ Rear gate handle

(LJ20V)

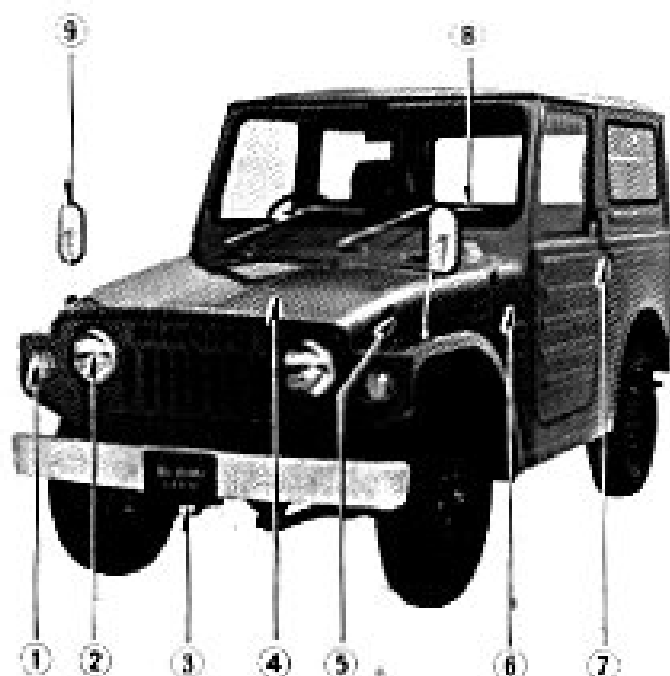

- | | | |
|--------------------------|-------------------------------|--------------------|
| ① Front turn signal lamp | ⑤ Engine hood hookshaped grip | ⑦ Side door handle |
| ② Head lamp | ⑥ Side turn signal lamp | ⑧ Windshield wiper |
| ③ Front towing hook | | ⑨ Rear view mirror |
| ④ Engine hood | | |

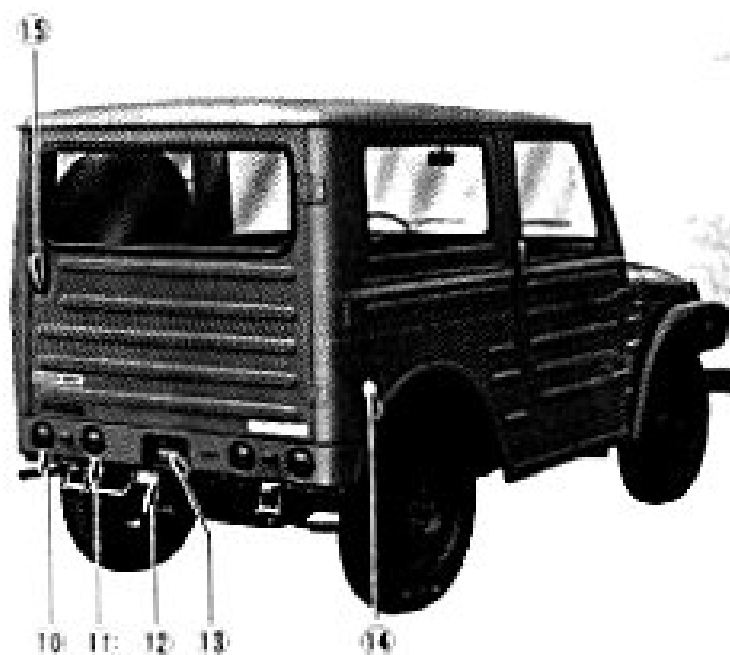

- | | | |
|--------------------------------------|--------------------|--------------------|
| ⑩ Rear turn signal/tail parking lamp | ⑫ Back up lamp | ⑭ Fuel tank cap |
| ⑪ Brake lamp | ⑬ Rear towing hook | ⑮ Rear gate handle |

Instruments and controls

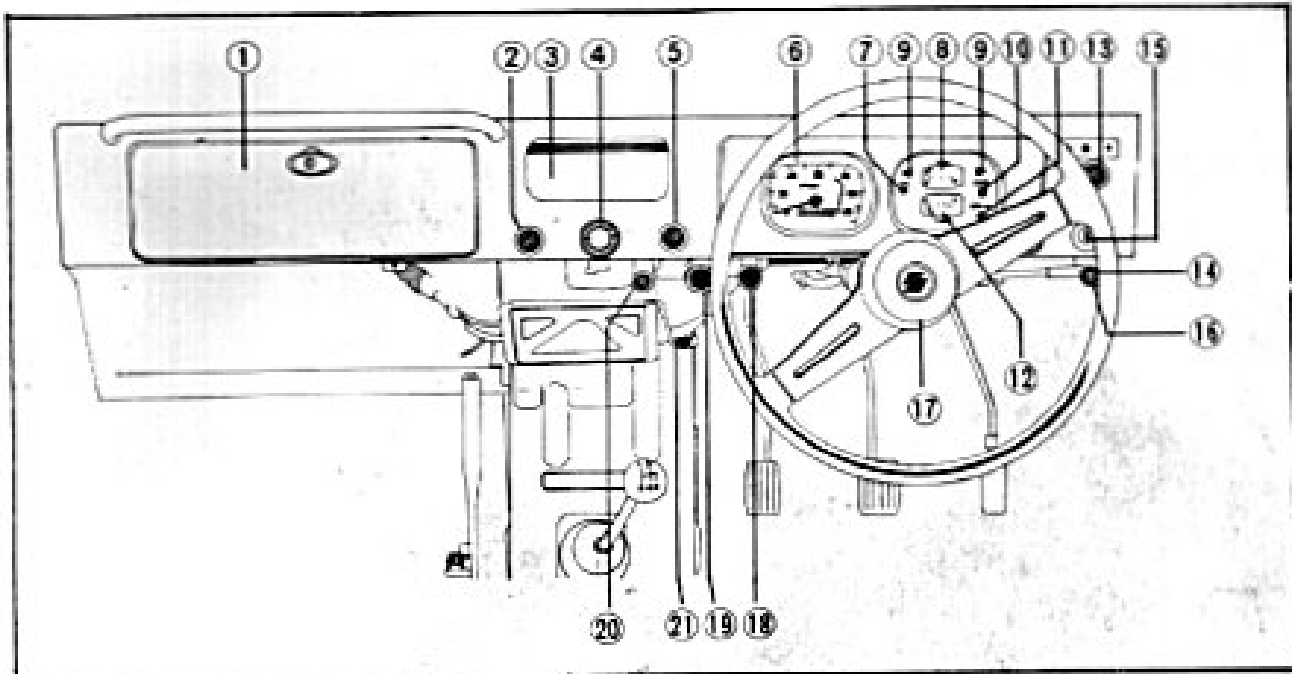

- ① **Glove compartment lid:** The spring loaded glove compartment lid stays either in the closed or fully open position. The glove compartment lid of the LJ20 can be locked with the ignition key.
- ② **Choke control knob:** The choke control knob should be pulled out when starting a cold engine. Driving with the choke pulled out after the warm-up period, increases fuel consumption.
- ③ **Ashtray:** The ashtray can be easily removed by pulling out the tray while depressing the retainer spring.
- ④ **Windshield washer:** The wind shield washer is operated by depressing on the pump when the windshield wipers are switched on. The water reservoir is in the engine compartment. It is advisable to add an approved cleaning solvent and anti-freeze to the water in the container.
- ⑤ **Windshield wiper switch:** The windshield wipers are operated by pulling out the switch.

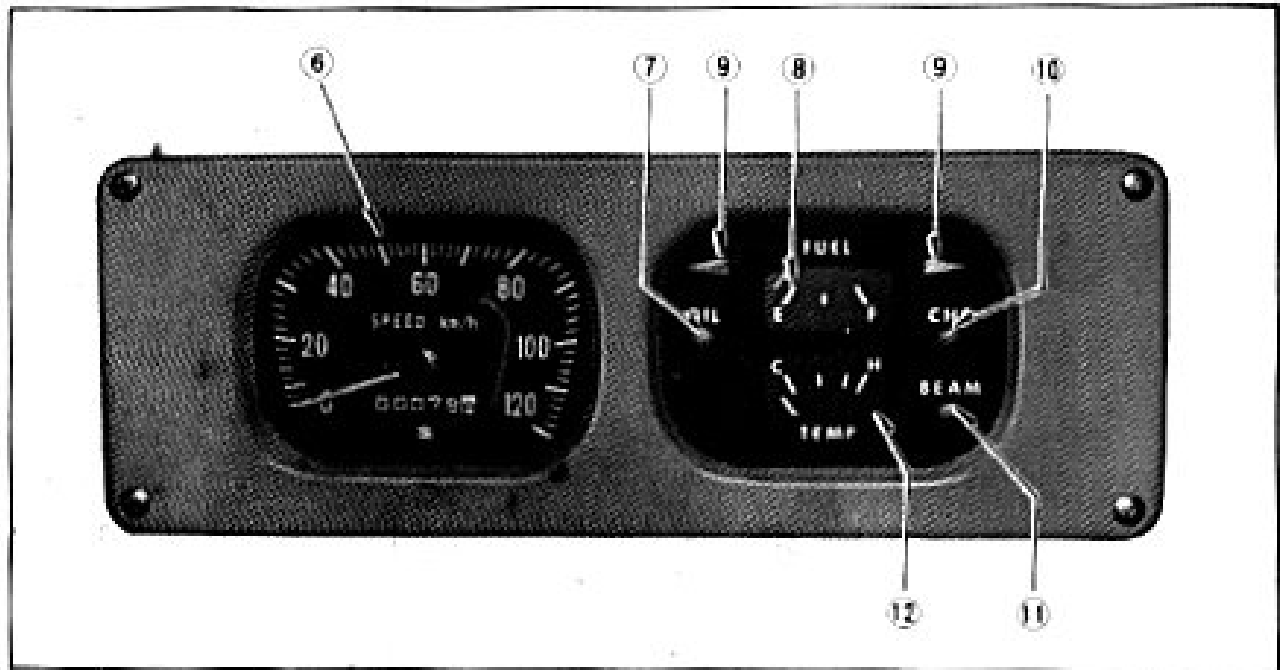

- ⑥ **Speedometer:** The speedometer indicates the vehicle speed. Speedometer readings may be in miles or kilometers, depending on the type of speedometer installed.
- ⑦ **Oil level indicator lamp:** When the engine oil level is adequate, the center of the oil level pilot lamp glows faintly with the ignition switch on. If the volume of engine oil in the tank drops below the minimum level 0.5 ltr (1.0/0.9 US/Imp pt), the pilot lamp glows brightly, indicating that you must add the recommended oil immediately. (See page 18).
- ⑧ **Fuel gauge:** The fuel gauge indicates the amount of gasoline in the tank. The "E" mark indicates the tank is empty or nearly so. The "F" mark indicates the tank is full. When the pointer reaches the "E" mark the tank contains approx. 4 ltr (1.1/0.9 US/Imp gal) of gasoline.
- ⑨ **Turn signal indicator lamp:** The lamp will flash when the turn signal lamp is operating.

- ⑩ **Charging indicator lamp:** The charging indicator lamp will show red when the ignition is switched on. The lamp is not lighted when engine speed are above idle speed and the generator is charging the battery.
- ⑪ **High beam indicator lamp:** The high beam indicator lamp shows blue when the head lamp high beam are on. This lamp goes out when head lamps are switched from high to low beam.
- ⑫ **Temperature indicator:** The temperature of the coolant is electrically indicated by the gauge when the ignition is switched on. After the initial rise in temperature during the warming-up period, any sudden upward change in the reading calls for immediate investigation.
- ⑬ **Lighting switch:** The lighting switch is pulled in two stages. Pull the switch to the first stage to switch on the parking, tail, licence plate and combination lamps and to the second stage to switch on the head lamps. When the lighting switch knob is turned to clockwise, the front and rear auxiliary parking lamps light.
- ⑭ **Self-cancelling turn signal & dimmer switch:** Moving the lever upward operates the left direction signal, moving it downward operates the right direction signal. A self-cancelling device switches off the direction signal when the steering wheel returns to the straight-ahead position. The head lamp beams can be changed from high to low or vice versa.
- ⑮ **Ignition switch:** The ignition switch can be switched to either one of the below listed position.

- A Ignition off. The key must be removed.
- B Drive position. The key can not be removed.
- C Start position. The key must be released as soon as engine starts. It then returns automatically to drive position.

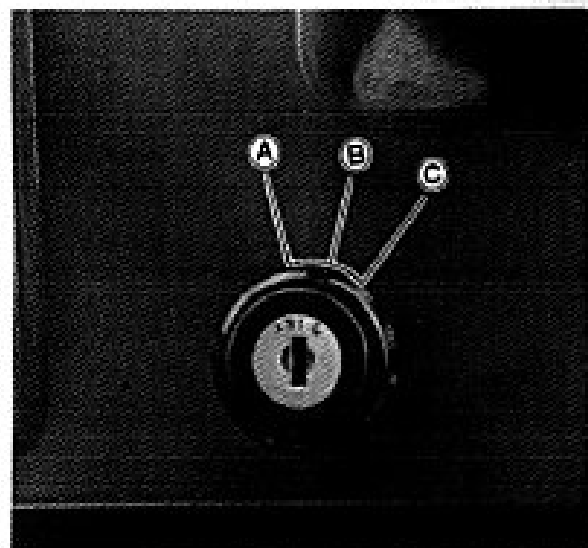

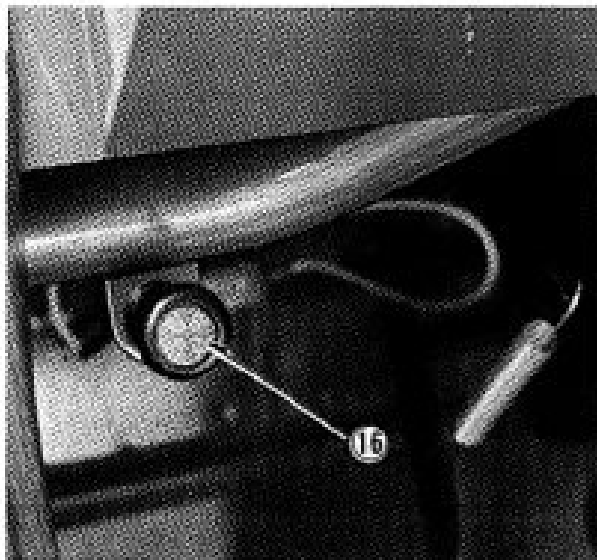

⑩ Hazard warning flasher switch: Use the warning flasher to warn other drivers any time your vehicle becomes a traffic hazard, day or night.

⑪ Horn button: The horn is blown by depressing the button when the ignition is on. The horn should be used only when necessary.

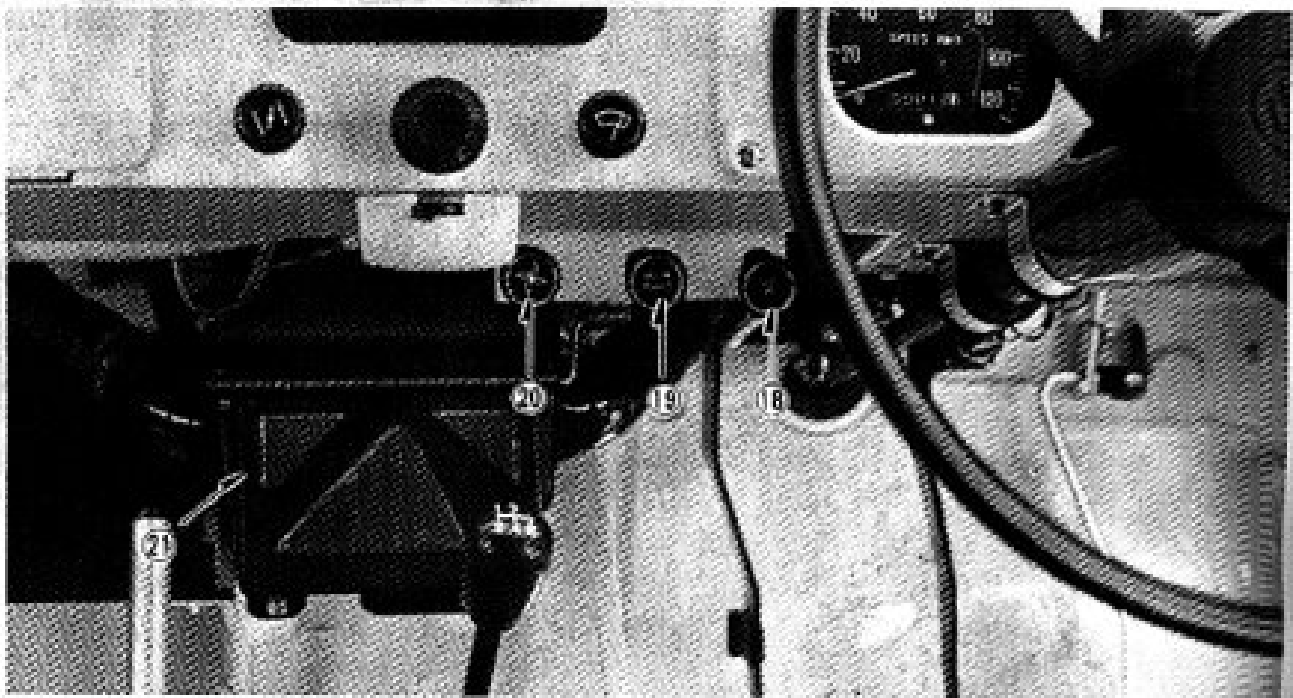

⑫ Ventilator knob: The ventilator knob opens and closes the ventilator lid. In order to allow the stale air to escape, open the ventilator by depressing the knob to the bottom position.

Note: For a vehicle which is not provided heater unit, pull the knob to open the ventilator lid.

⑬ CIRC-FRESH knob (Only for a vehicle provided heater unit): This knob regulates the temperature either cold or warm or any desired temperature within this range-

Forward position Warm
 Backward position Cold

- 20 Blower switch knob (Only for a vehicle provided heater unit): This knob operates the blower in two stage-

- A Position, blower switched off
- B Position, blower running at half speed
- C Position, blower running at full speed

Note: In order to prevent engine overcooling, the blower does not operate while a pointer of the temperature indicator is below "C" mark.

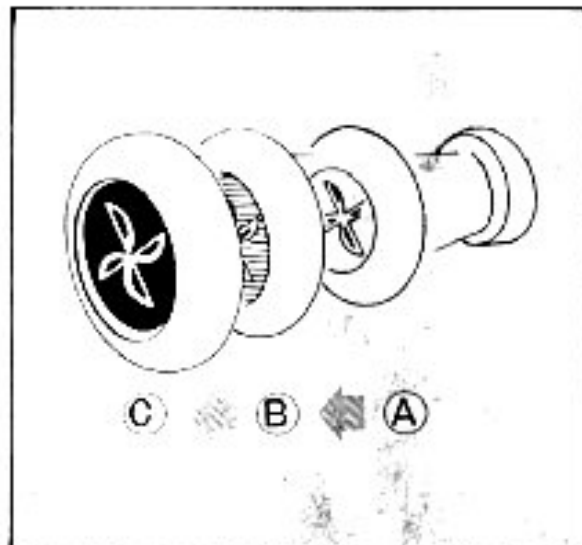

- 21 Defroster control lever (Only for a vehicle provided heater unit): This lever regulates the distribution of air.

Forward position, defroster jets
Backward position, heater outlet-
and any desired position within
this range.

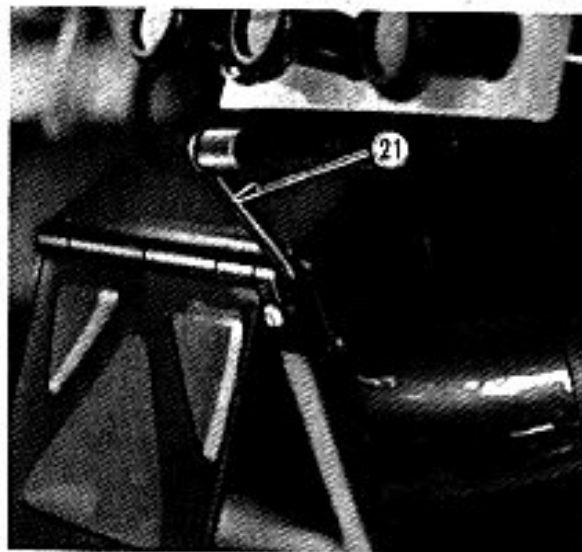

Caution: The water passage to the heater unit should be shut in summer season by screwing in the valve, which is provided in the engine compartment, until it bottoms completely.

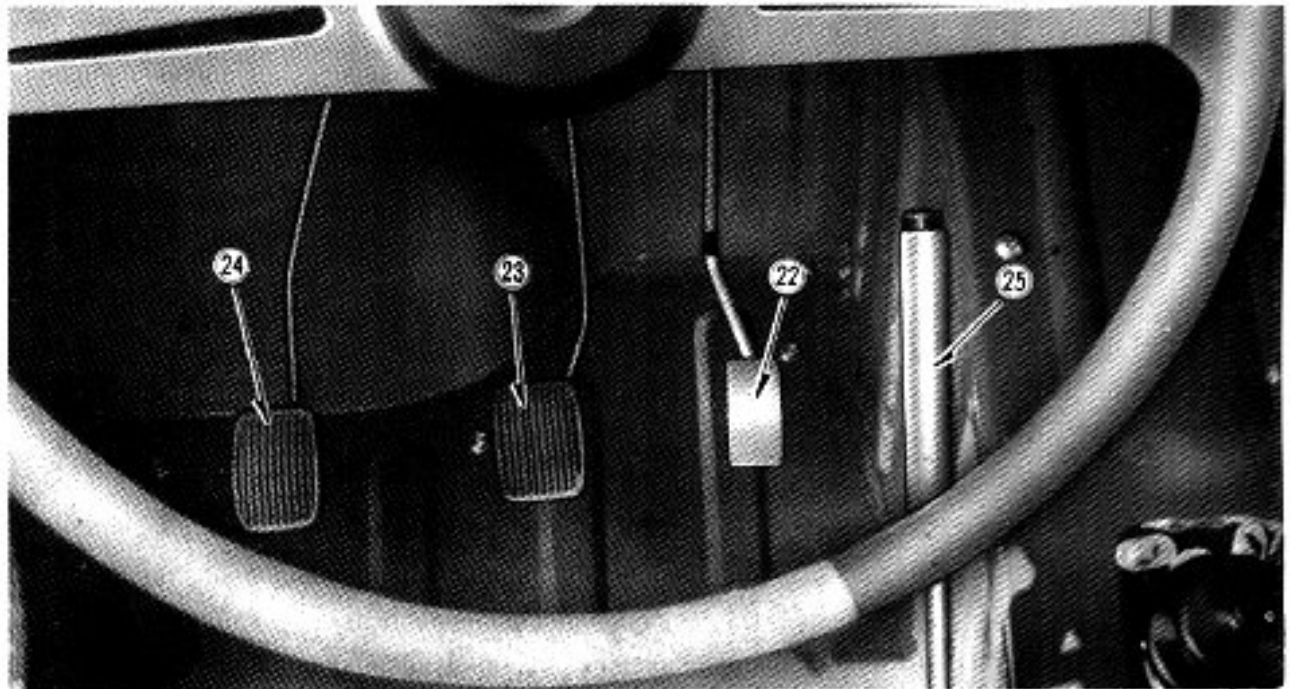

- ② Accelerator pedal: The accelerator pedal controls the engine speed. Proper operation avoids brake applications and ensures fuel economy.
- ③ Brake pedal: The brake pedal operates the hydraulic service brake and should be used gently. It should be depressed with full force for emergency stops only.
- ④ Clutch pedal: The clutch pedal should not be used as a foot rest as excessive clutch release bearing and lining wear will result.
- ⑤ Parking brake lever: LJ20 and LJ20V are provided an exclusive brake drum for parking to lock the rear propeller shaft. The foot brake should not effect as the result of soaking water in the brake drum while driving on puddle road, you could use the parking brake instead of the foot brake. The parking brake is of the pull up type, operating mechanically on the wheels. To release the parking brake, pull it upwards to take the load, press the ratchet release button located, in the end of the lever with the thumb and push the lever down into the off position.
- Note:** For LJ20, the parking brake lever lock is provided on the base of the lever to prevent theft. To lock, insert the lock key and turn it clockwise.

②6 **Gearshift lever:** All forward gears are synchronized.

N position, neutral

1 position, first speed for starting and very steep grades

2 position, second speed for not so steep grades

3 position, third speed for small grades

4 position, fourth speed for city traffic

R position, reverse

Note: The gearshift lever must be pushed down and moved to the right to overcome the resistance of the locking mechanism before engaging reverse.

②7 **Transfer control lever:**

Normal position, rear wheel drive for city traffic

H position, high speed for wheels drive for muddy or sandy field

N position, engine power is not transferred.

L position, low speed four wheels drive for waste land or extreme steep grades

Caution: Any gear of transfer must be engaged only when the vehicle is not in motion. Use the four wheels drive only for off-the-road condition.

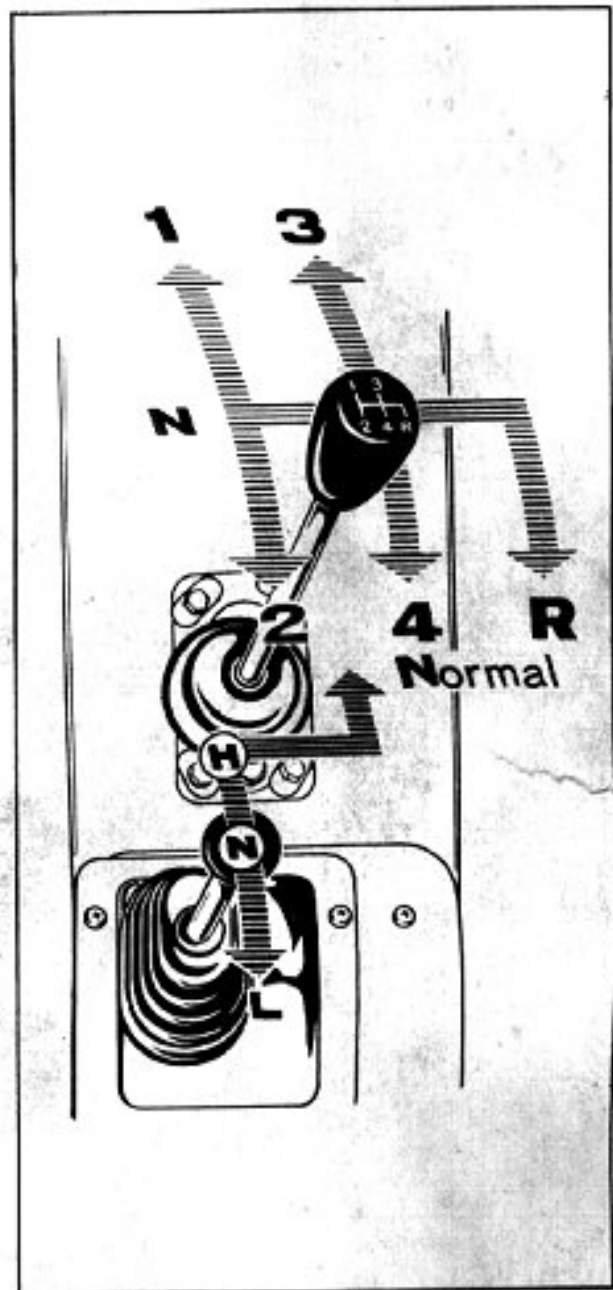

After the information on the instruments and controls you should also notice the following hints regarding the operation of hood lock, door lock and rear gate lock.

Engine hood: Remove two hook shaped grips (A) located on the front fenders. To support the open hood, gently lean it against the rubber stopper (B) which is fixed above the windshield.

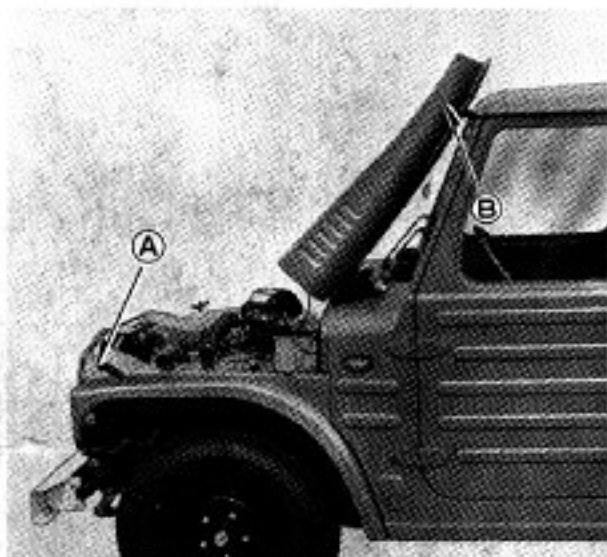

Canvas door and window (LJ20): The canvas door can be opened by turning the handle (C) downward. To open the windows, roll the windows after removing the hooks and fix it with two bands (D) provided on the door.

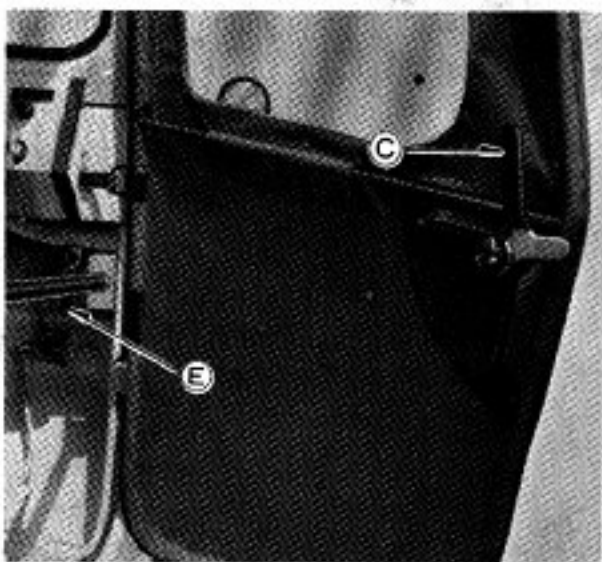

Front gate bar (LJ20): Getting on and off a vehicle, pull the knob (E) toward you and let the bar down with the knob pulled. Be sure that the front gate bars are locked securely before starting the vehicle.

Side door (LJ20V): The ignition key fits the driver's door lock. After unlocking the door can be opened by pulling out the door handle A. The assistant's door can also be secured by moving the door inside handle B forward.

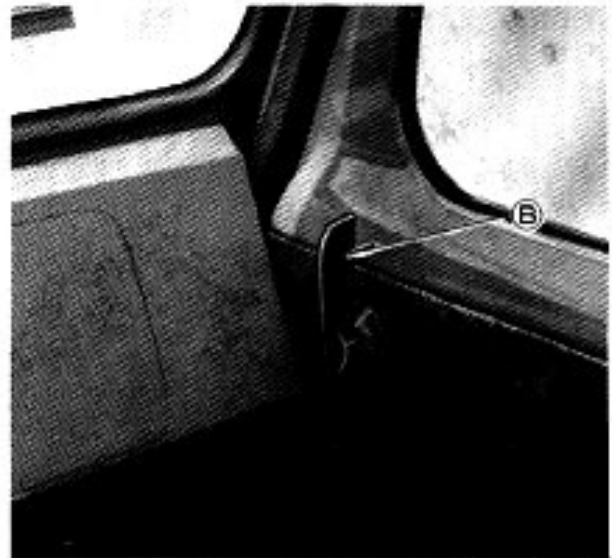
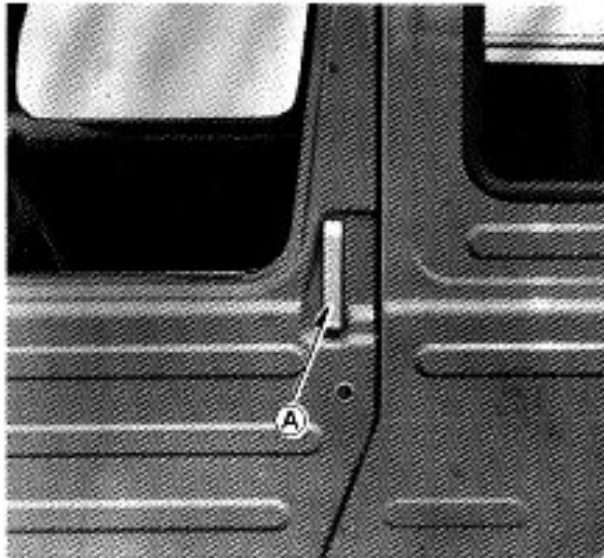

Tail gate (LJ20): The tail gate of the LJ20 can be opened and shut with the lock handle C after removing the spare tire holder.

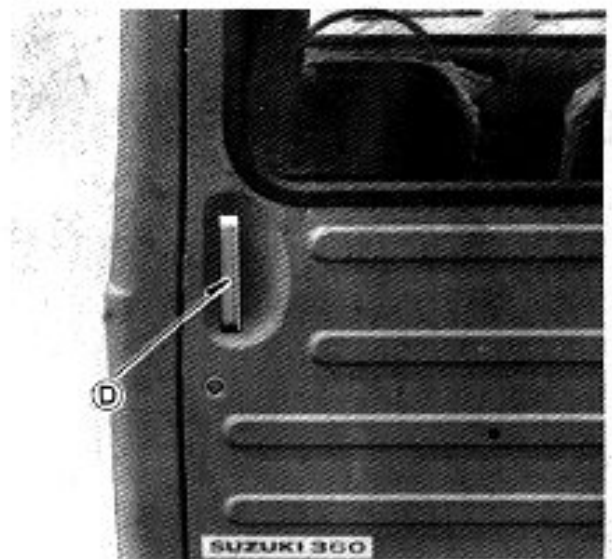
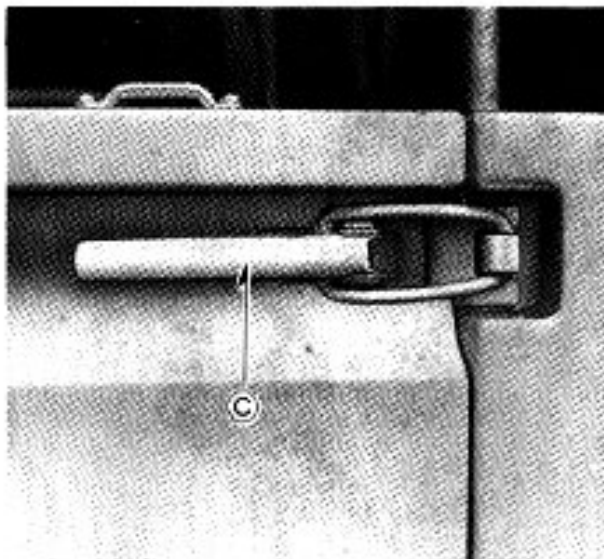

Tail gate (LJ20V): The tail gate of the LJ20V is locked with the door and ignition key. To lock the tail gate, turn the key clockwise. After unlocking, the tail gate is opened by pulling out the door handle D.

Rear curtain (LJ20): To open the rear curtain, remove three rubber bands from the hooks of the rear gate and unfasten two belts. Twist a knob of the clasp and separate it one after another. Roll the rear curtain and fix it with two bands.

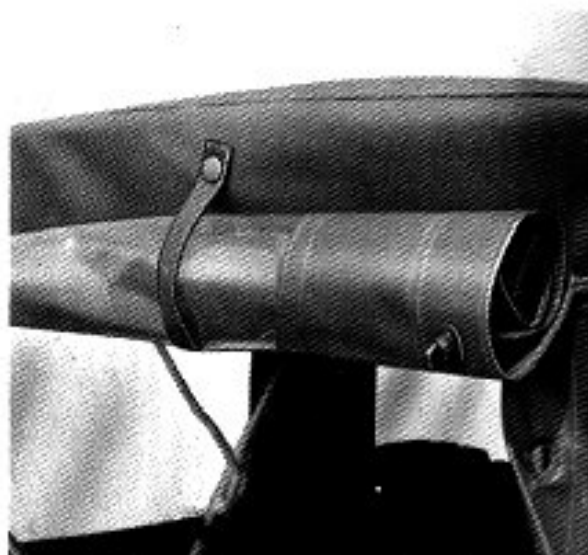
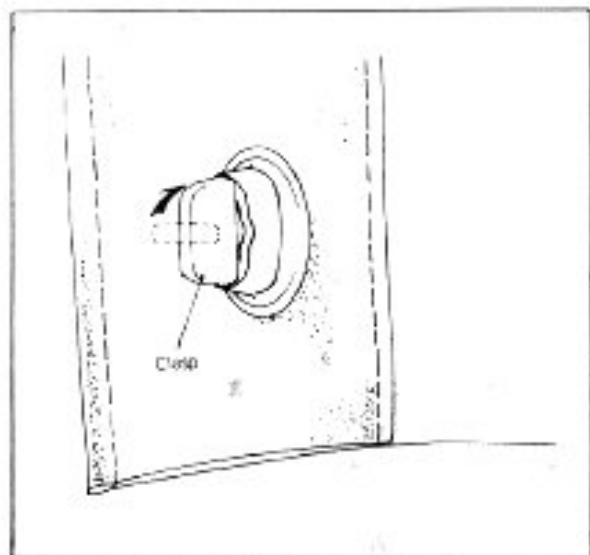

Note: Side curtain opening can be performed by similar procedure as described above.

Interior lamp: The interior lamp of LJ20 is on by sliding the knob to the right side and turns off by sliding the knob to the left side. The interior lamp of the LJ20V is on by sliding forward and turn off by sliding backward.

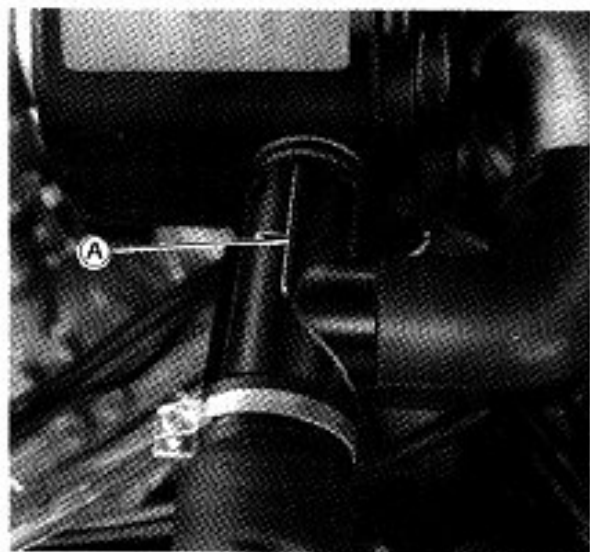

Air intake control lever: To ensure adequate engine protection rotate the lever (A) located on cleaner intake duct to exclude the admission of cold air. Rotate the lever according to the labelled instruction.

HOW TO TREAT NEW CAR

Break-in

The treatment given to a new car will have an important bearing on its subsequent life, and engine speeds during the period must be limited. The following instructions should be strictly adhered to.

MILEAGE	MAXIMUM RECOMMENDED SPEEDS							
	1st gear		2nd gear		3rd gear		4th gear	
	kph	mph	kph	mph	kph	mph	kph	mph
Up to 1,000 km (600 miles)	15	10	25	16	40	25	55	35
From 1,000 to 3,000 km (600 to 1,800 miles)	Speed limits may be gradually increased up to the max. rated speeds.							

Transfer gear is in "Normal" or "H" position.

Never exceed the break-in speeds indicated above.

Never drive at the maximum speeds recommended above for long stretches, especially on climbs.

After starting, do not race the engine; warm up gradually.

For the first tankfull, use a petrol mixed at the ratio 20-30 parts gasoline to 1 part engine oil.

Fuel and oil

Fuel: The use of correct gasoline is very important for your engine. Gas used should be graded 85 to 95 octanes in Research Method.

Engine oil: Use Suzuki CCI oil. It is formulated to give best engine performance with least combustion chamber deposits, least pre-ignition, maximum spark plug life and best lubrication. If the Suzuki CCI Oil is not available, use one of the recommended oils given below.

When the temperature is below 10°C (50°F)

SHELL 2T TWO STROKE OIL.
SUPER SHELL MOTOR OIL.
MOBIL SUPER MOTOR OIL.

When the temperature is above 10°C (50°F)

SHELL 2T TWO STROKE OIL.
SHELL OUTBOARD ENGINE OIL.
SUPER SHELL MOTOR OIL.
MOBIL OUTBOARD OIL.
MOBIL SUPER MOTOR OIL.
ESSO 2T MOTOR OIL.
ESSO OUTBOARD OIL.
CALTEX 2T PLUS MOTOR OIL.
STANDARD OUTBOARD OIL.
UNION 76 OUTBOARD OIL.
TEXACO OUTBOARD OIL.

Transmission, transfer, rear and front axle oil: A good brand of SAE 80 gear oil should be used for this vehicle.

Brake fluid

Fill the reservoir with brake fluid graded "DOT 3" or "DOT 4" in USA and equivalents in other countries.

Note: Since the brake system of this vehicle is filled with a glycol-based brake fluid in the manufacturer, do not use or mix different types of fluid for refilling the system, otherwise the serious damage will be caused. Do not use any brake fluid taken from old or used or unsealed containers.

Anti-freeze mixture

At the factory this vehicle is filled with a mixture of 30% "GOLDEN CRUISER #1200" to 70% water. In extremely cold areas, where more anti-freezing properties are required, the percentage of Anti-freeze may be increased using the following table.

Freezing Point	-10°C (14°F)	-15°C (5°F)	-20°C (-4°F)	-25°C (-13°F)	-31°C (-24°F)	-39°C (-38°F)
Anti-freeze: % in volume	30	35	40	45	50	55

Should the "GOLDEN CRUISER #1200" anti-freeze mixture not be available use equivalents of high commercial quality, following the labelled instructions.

HINTS FOR DRIVING

Before turning on the ignition switch, make sure that the gearshift lever is in neutral, and select the transfer gear according to the road condition (See page 13.), or better disengage the clutch to eliminate the friction in the transmission. This applies especially to winter operation. Simultaneously depress the accelerator pedal slightly. As soon as the engine starts release the switch. When the engine is cold and outside temperature is low, the choke knob should be pulled out completely. Operate the starter without depressing the accelerator pedal. As the engine starts, the choke knob should be pushed in gradually or completely according the engine temperature.

Caution: The starter should not be operated longer than five seconds at one time.

Do not start the engine in a garage with closed door. The doors must be opened to prevent accumulation of carbon monoxide gas.

When changing gears or starting do not race the engine. This shortens the engine life and prevents smooth shifting. All forward speeds are synchronized, which provides for noiseless gearshifting. The synchronization makes gearshifting easy, and only little effort is required to move the control lever. It is not necessary to double de-clutch nor to accelerate in neutral when shifting down.

During operation of the car the driver should periodically observe the instruments and indicator lamps. Avoiding sharp brake applications and fast accelerations whenever possible will increase fuel economy.

When driving in mountains this vehicle will not only climb any grade encountered in public road, but off-the-road because of its distinguished gradeability. The most common error made, is delaying a shift into the next lower gear. Many times the vehicle is driven in fourth until the engine labors and vehicle speed drops too low to operate in third gear, thus making it necessary to shift into second or even first gear.

Caution: Never try to avoid gearshifting by slipping the clutch.

When driving downhill, especially on long and steep grades, use the engine as a brake. Do not switch off the ignition and avoid over-running the engine with the accelerator pedal released for long periods of time.

When starting on a grade, the parking brake should be released as the clutch is engaged and the engine starts to move the vehicle. If the vehicle is parked at the top of a hill after a strenuous uphill drive, the engine should be allowed to idle for a short time. If the engine is stopped suddenly, the accumulated heat might cause the coolant to boil, resulting in loss of coolant. The same rule applies if it is necessary to park on a grade after the vehicle has been climbing for some distance.

Fuel consumption will be regulated by driving habits and operating condition. A medium, steady speed is most economical as much fuel is wasted by reducing and resuming speed. It is easy on the car and keeps the engine at the correct operating temperature. Driving with engine too cold increases the fuel consumption and the engine wear.

INSPECTION AND MAINTENANCE

Inspection before driving

If just a little attention is paid to the following items, it is possible to avoid occurrence of troubles and or inconveniences during the use of the car.

1. Turning on the ignition switch, check the fuel amount in the tank by the fuel gauge reading.
2. Check the engine oil level in the oil tank after opening the engine hood and add if necessary. (See page 18 for recommended oil.)
3. Check the brake pedal to make sure that it functions properly. (See page 32 for its adjustment.)
4. Check that the brake fluid level is above the ridged line on the reservoir. If necessary, replenish the reservoir with recommended brake fluid. (See page 19.)
5. Check the parking brake lever to make sure that it functions properly. (See page 33 for its adjustment.)
6. Check the clutch pedal to make sure that it functions properly. (See page 32 for its adjustment.)
7. Check the tires for proper inflation pressure. (See page 36.)
8. Check all lighting equipment for proper operation. (See page 39 for bulb replacement.)
9. Check the steering wheel for excessive play and irregularities. The standard steering wheel play should be 10-30 mm (0.4-1.2 in) along the steering wheel. If you find excessive play, have your vehicle inspected at an authorized Suzuki dealer.
10. Check the water pump belt for sag and crack. (See page 27.)

Periodic inspection chart

First 1,000 km (600 miles)

1. Spark plug Check & clean
2. Ignition timing Adjust
3. Oil pump & oil pipe Check leakage
4. Carburetor Adjust idling
5. Brake pipe Check leakage
6. Wheel & hub nut Retighten

Every 2,000 km (12,000 miles)

7. Air cleaner element Clean

Every 3,000 km (1,800 miles)

8. Spark plug Clean

Every 6,000 km (3,600 miles)

9. Ignition timing Adjust
10. Oil pump & oil pipe Check leakage
11. Carburetor Adjust idling & throttle cable
12. Brakes Adjust shoe clearance
13. Brake pipe Check leakage
14. Wheel & hub nut Check for loose
15. Tire Rotate
16. Wheel alignment Check and adjust
17. Spark plug Replace

Every 10,000 km (6,000 miles)

18. Air cleaner element Replace
19. Oil pump & oil pipe Check & adjust

Every 40,000 km (25,000 miles)

20. Fuel filter Replace

Lubrication chart

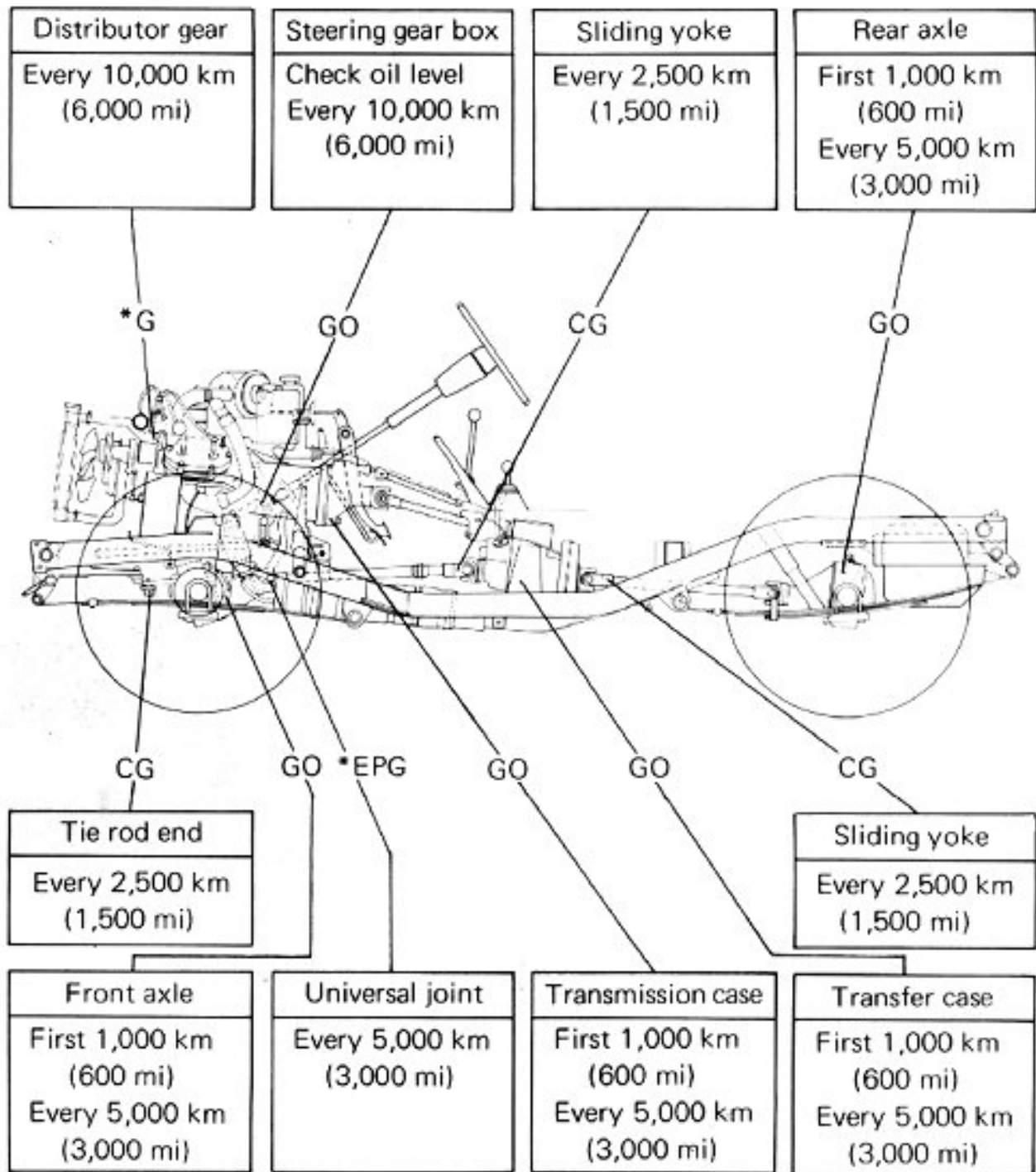

Note: (GO) Gear oil SAE 80
(CG) Chassis grease

(*G) Super grease C (Suzuki)
Albania grease No.3 (Shell)
Regal Starfak No.3 (Caltex)
Mobilux No.3 (Mobil)
Andok C (Esso)
Cup grease No. 250

(*EPG) Albania EP2 (Shell)
Multifak EP2 (Caltex)
Mobilplex No.2 (Mobil)
Nebula EP2 (Esso)

Fuel system

Air cleaner: If the air cleaner is clogged with dust, intake resistance will be increased with a resultant decrease in out put and increase in fuel consumption. Take off the element after removing two clips A and clean or replace it at regular intervals (See page 23.).

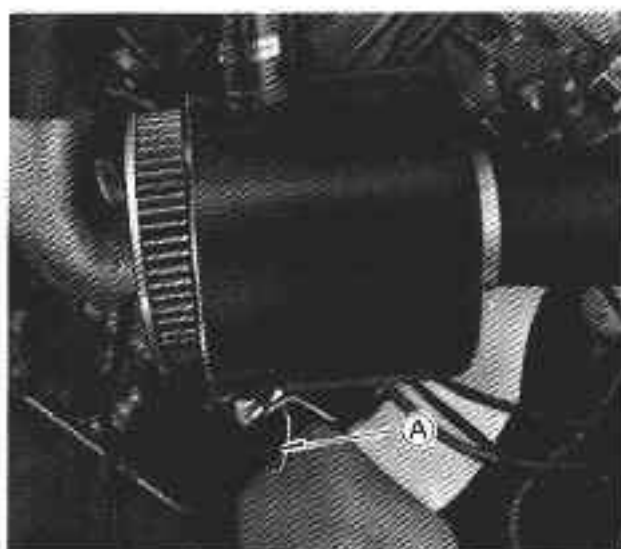

Fuel filter: The fuel filter is located in the engine compartment. This filter is of an anti-disassembling type needing no inspection and cleaning in short covered mileage. To replace it, remove the fuel hoses from outlet and inlet tap and replace the filter at regular intervals after loosening the clamp bolt B.

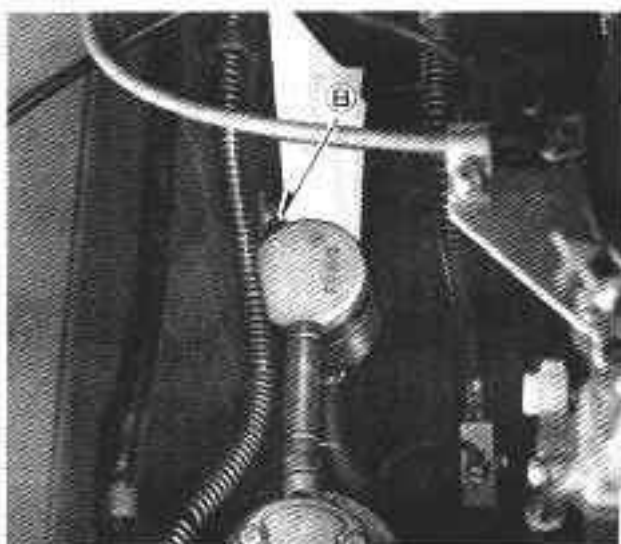

Carburetor: The idling speed should be adjusted only in the case of irregular engine operation. Do it as follows when engine is warm.

Start the engine and slowly turn the idle adjustment screw C in or out within $\frac{1}{4}$ turn until the engine runs smoothly and begins to pick-up speed.

Turn the throttle stop screw D in or out as required to obtain an idling speed of 900-1,000 rpm.

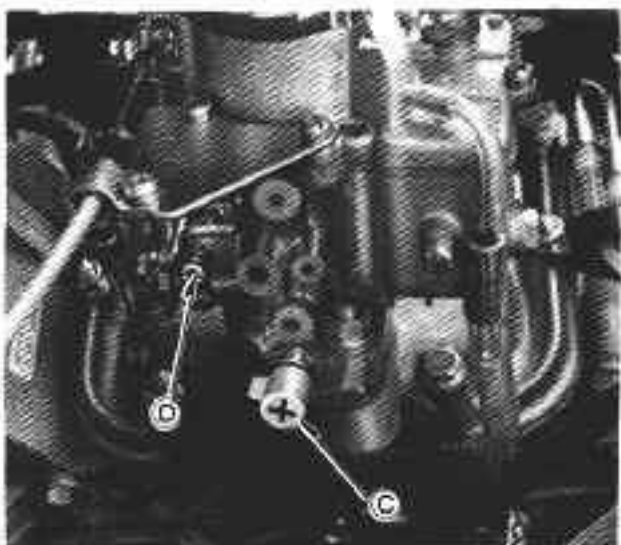

Cooling system

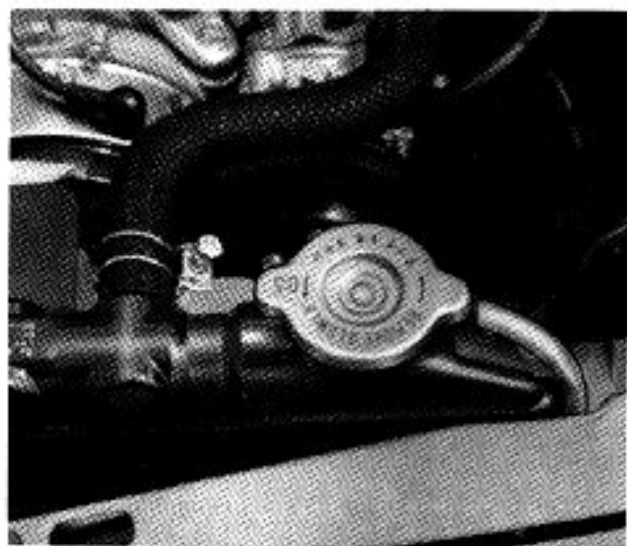

Radiator cap: A pressurized cooling system is used on this vehicle and the pressure must be released gradually when removing the radiator filler cap if the system is hot. It is advisable to protect the hands against escaping steam and then turn the cap slowly counter-clockwise.

Warning: In no circumstances should the filler cap be removed if the coolant temperature is above boiling point, or if the engine is running.

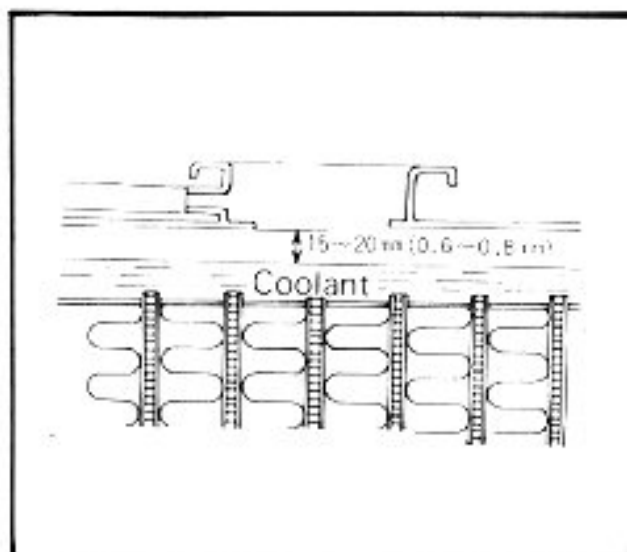

Topping up: Top up the cooling system with soft water in accordance with the labeled instruction. If a large amount is required to be added, mix anti-freeze/water to the required ratio (See page 19.1 before replenishing, so as not to dilute the mixture.

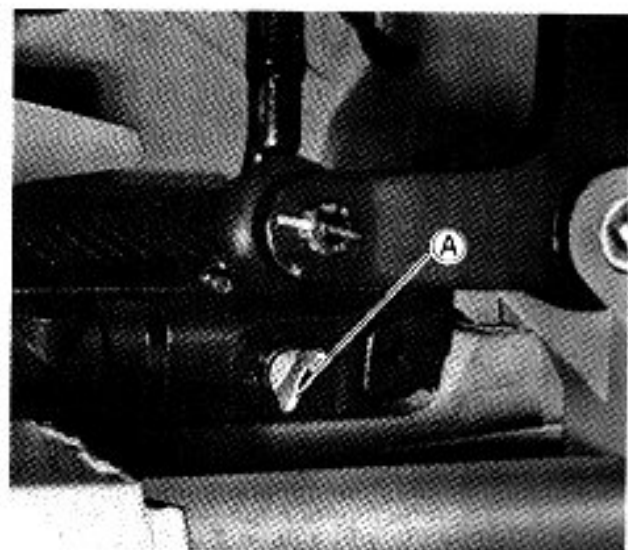

Coolant: Normally, the coolant should be drained and changed every two years or 35,000 km (20,000 miles). To change the coolant, remove the radiator cap and the drain plug A, and drain off the old coolant. Flush the system by running a garden hose

through the radiator filler. Refit the drain plug and run the engine for ten minutes with only water inside. Then re-drain the system and fill with prescribed anti-freeze/water mixture.

After running the engine for several minutes, check the coolant level and top up the cooling system if necessary.

Caution: Do not mix different brands of coolant within the cooling system.

Water pump belt: Through use the belt can slacken and slip, causing belt crack. Hence have belt checked periodically for proper tension which is correct when under a pressure of about 5 kg (11 lb), sag is about 10 mm (0.39 in). If necessary, adjust as follows or replace it.

Back out the four pulley-to-hub mounting nuts (A)

Remove outer semi-pulley (B), take out one (or more depending on belt slackness) of the spacer rings (C) forming the pulley groove.

On re-installing the pulley, the rings - if more than one was removed - should be suitably distributed two outer faces of the pulley.

Secure the pulley by the four nuts.

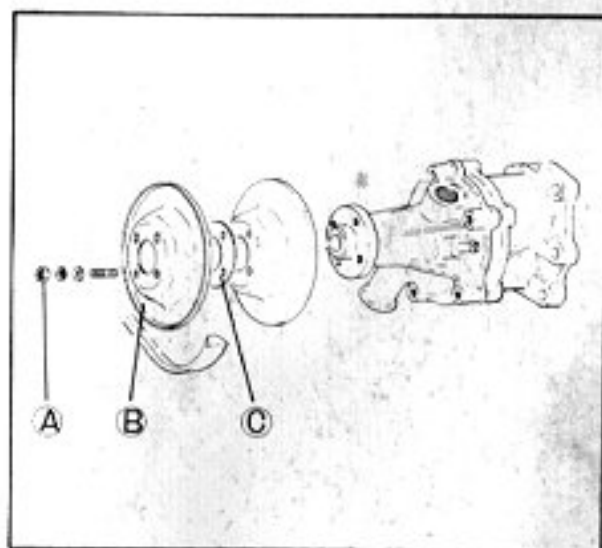
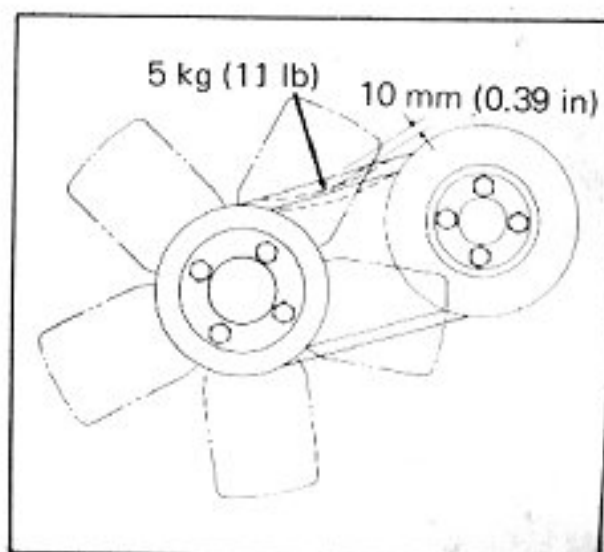

Lubrication system

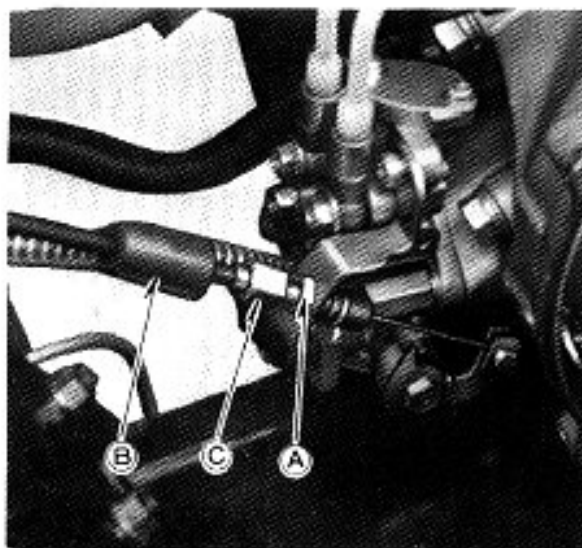

Oil pump: The oil pump control lever regulates the amount of oil discharged from the oil pump.

Loosen the oil pump cable adjuster lock nut A after removing the rubber boot B, then turn the adjuster C separate the lever from its stopper.

Turn the adjuster in reverse direction until the lever touch upon the stopper.

Be sure to secure the adjuster with lock nut and cover it with the boot.

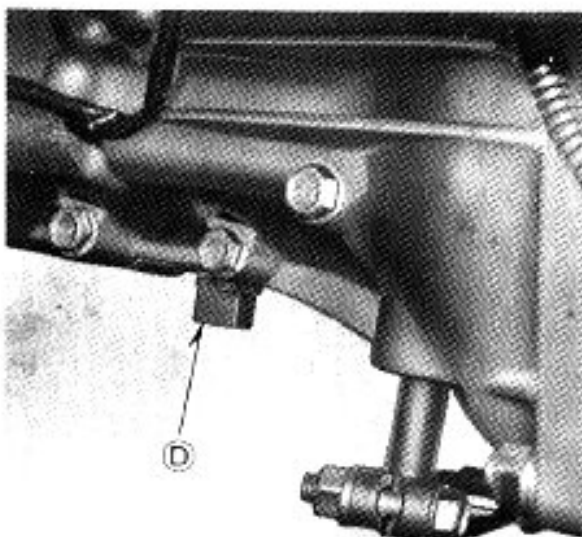

Transmission case: Draining oil should be performed while the engine is still warm as this will assure complete and rapid draining, saving much time.

Remove the oil filler plug D located on the right side of the transmission case and the drain plug E located on the lower part of the case. Drain off the old oil completely.

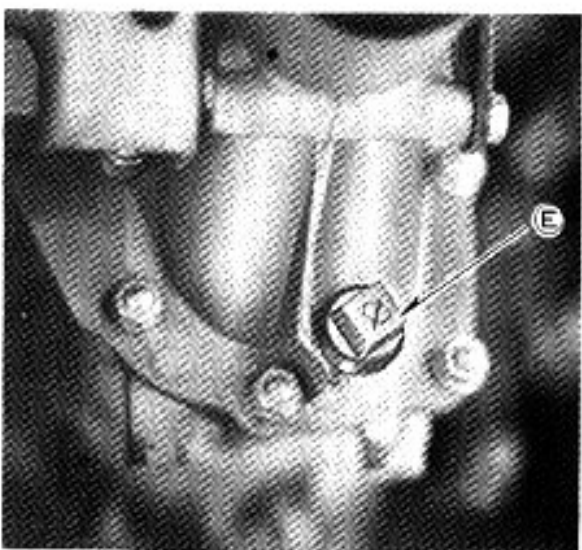

After tightening the drain plug, pour the recommended oil (See page 18.) into the case from the filler hole until oil over flows from the hole.

Screw in the filler plug.

Specified oil amount: 1,200 cc (2.5/2.1 US/Imp pt)

Transfer case: Remove the oil filler plug A located on the upper part of the transfer case and the oil drain plug located on the lower part of the case.

Drain off the old oil completely. Then tighten the drain plug and pour the recommended oil into the case. Refit the filler plug.

Specified oil amount: 700 cc (1.5/1.3 US/Imp pt)

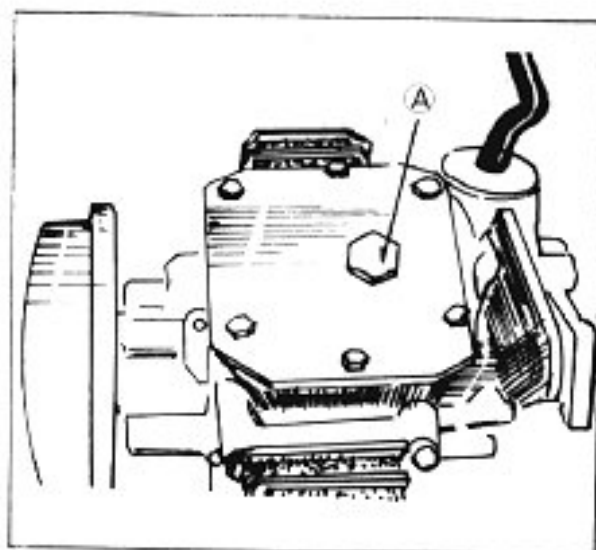

Steering gear box: Check to see that the oil is kept up to the oil inlet after removing the oil filler plug B at regular intervals (See page 24.) If the oil amount is insufficient, add the recommended oil.

Specified oil amount: 190 cc (6.4/6.7 US/Imp oz)

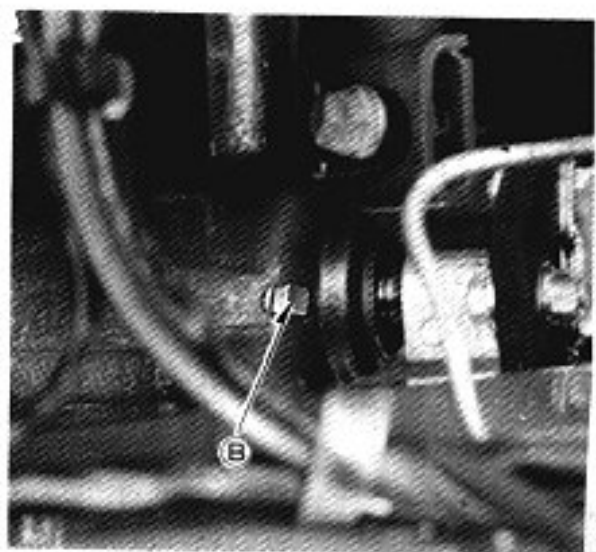

Rear and front axle: Remove the oil filler plug C and the oil drain plug D.

Drain off the old oil completely.

Then retighten the drain plug and pour the recommended oil into the case. Refit the filler plug.

Specified oil amount: 800 cc (1.7/1.4 US/Imp pt)

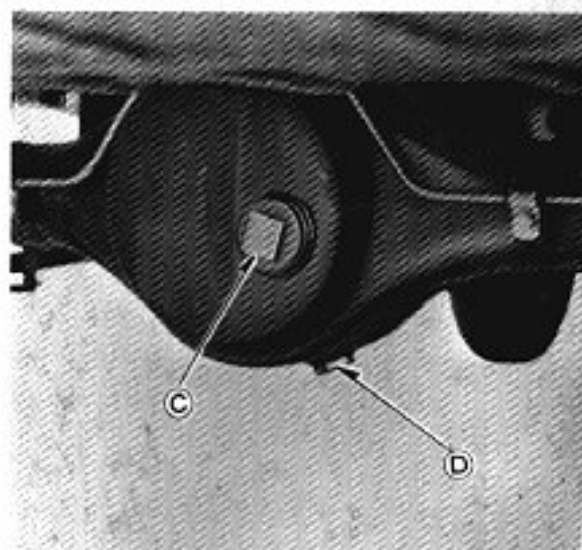

Ignition system

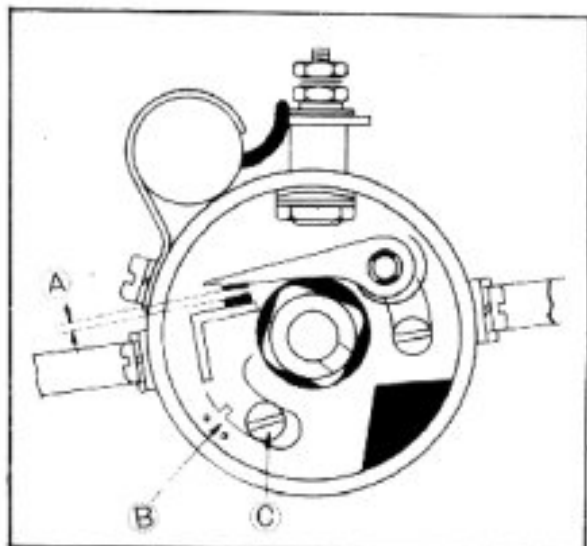

Ignition timing may change during the long time use of the vehicle, causing poor engine performance. Adjustment is performed by following procedure.

Contact point: Check the contact point gap A which must be 0.4-0.5 mm (0.016-0.020 in); adjustment is obtained by suitably displacing the stationary contact point plate B after slackening the fitting screw C. Re-lock the screw.

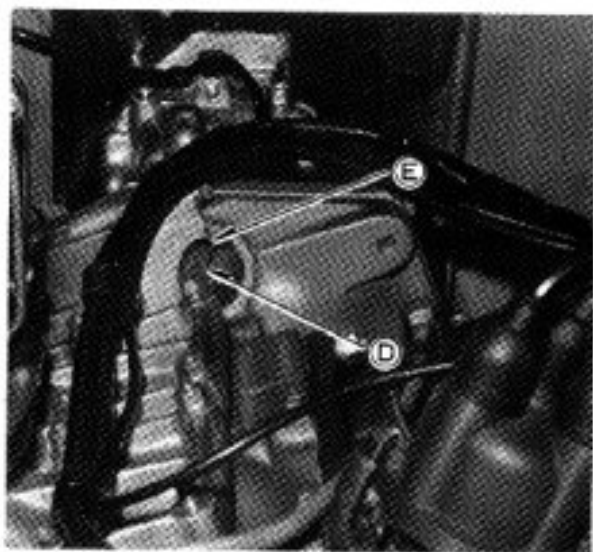

Caution: Whenever replacing the contact point or adjusting the gap, it is necessary to readjust the ignition timing.

Ignition timing: Remove the spark plug of cylinder No.1 and connect with the high tension cord and place it on the cylinder head.

Align the timing mark (D) on the flywheel with the embossed mark on the crank case.

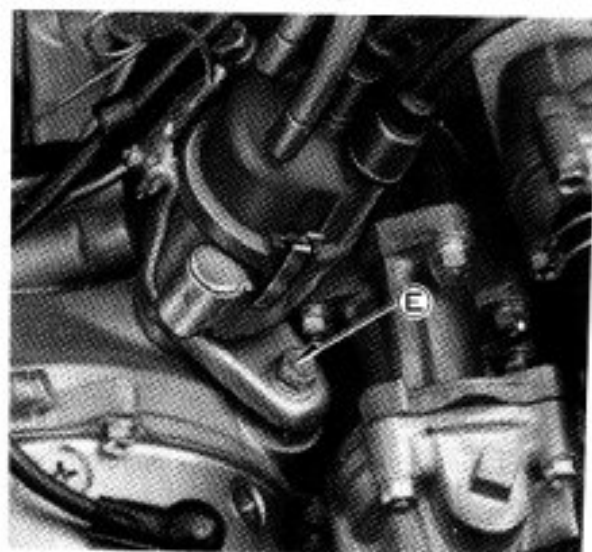

Slacken the bolt E locking the distributor on support.

Turn the distributor to the right slightly, and turn on the ignition switch, then turn it to the left slowly and stop it just when the plug sparks. Secure the distributor locking bolt.

Spark plug: The recommended spark plug for your vehicle is NGK BP6HS or Nippon Denso W20FP. If the standard spark plug is unsuitable for your usage, that is apt to overheat (porcelain shows whitish appearance) or get wet (black appearance), change it as follows.

	NGK	Nippon Denso	Remarks
Hotter type	BP4HS	W14FP	When apt to get wet.
Standard	BP6HS	W20FP	
Colder type	BP7HS	W22FP	When apt to overheat.

If another brand of spark plug is to be used other than NGK or Nippon Denso, consult your authorized Suzuki dealer.

Caution: Indiscriminate experimentation with different brands and heat ranges of spark plugs by the owner can, in some cases, cause engine problems. When installing the spark plug, screw it in with your fingers, to prevent stripping the threads, then tighten with a torque wrench to 3.5–4.0 kg-m (18.0–21.6 ft-lb).

When carbon accumulates on the spark plug, a hot, strong spark will not be produced. Remove carbon deposits with a wire or plug cleaner and adjust the spark plug gap A 0.6–0.7 mm (0.024–0.028 in) for NGK and Nippon Denso by measuring with a thickness gauge.

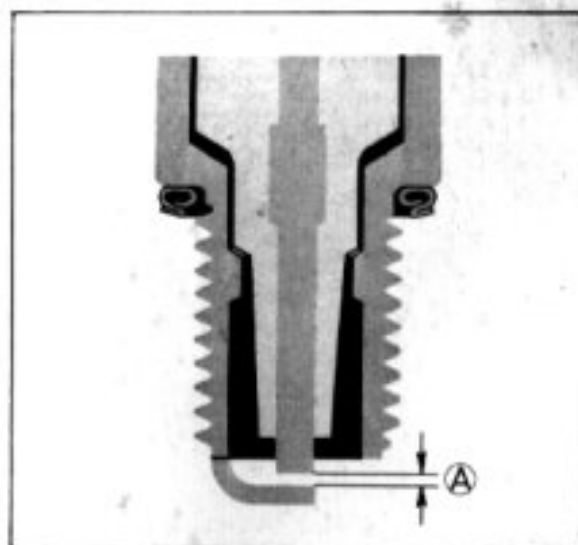

Chassis

Clutch: Should the clutch show a tendency to slip, check that clutch pedal is set for an approximate 20–30 mm (0.8–1.2 in) free travel A .
If necessary, readjust by the adjusting nut B in the engine compartment.

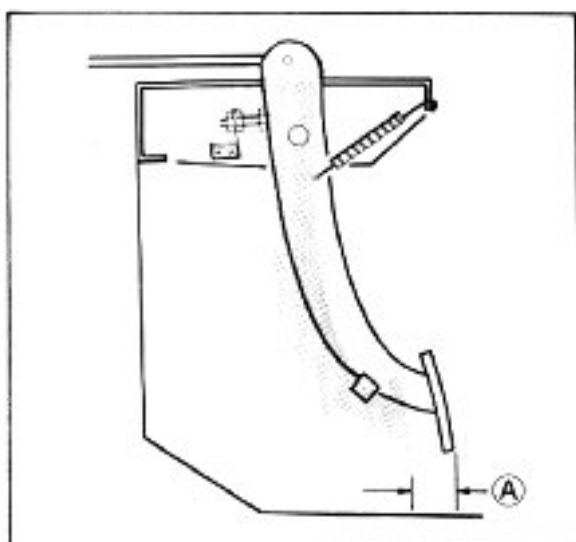

Brakes: If the brake pedal free play has become excessive or if braking unbalance on one wheel is appreciable, a clearance between the brake shoe and drum must be adjusted as follows.

Jack up the vehicle as described on page 34. Make sure the wheels are locked by wheel blocks in pairs instead of locking the parking brake to prevent vehicle movement.

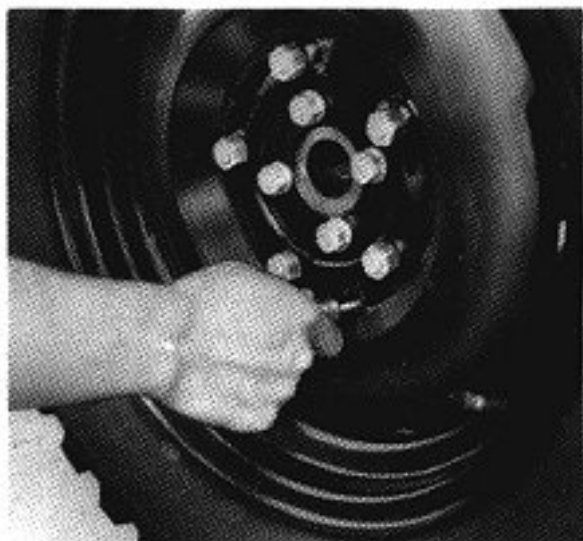

Remove a rubber cap on the drum and rotate the wheel until one of the adjustment notched sleeves C is visible through a hole in the wheel and brake drum.

Insert a plane head screw driver and pry the notched sleeve outward using the hole as a fulcrum until the brake shoe bears hard against the drum.

Back off the adjustment, usually 3 or 4 clicks, until the wheel is free to rotate without the shoe rubbing against the drum.

Turn the wheel until the other side notched sleeve is visible and carry out the same procedure.

Repeat the same operations on the other wheels.

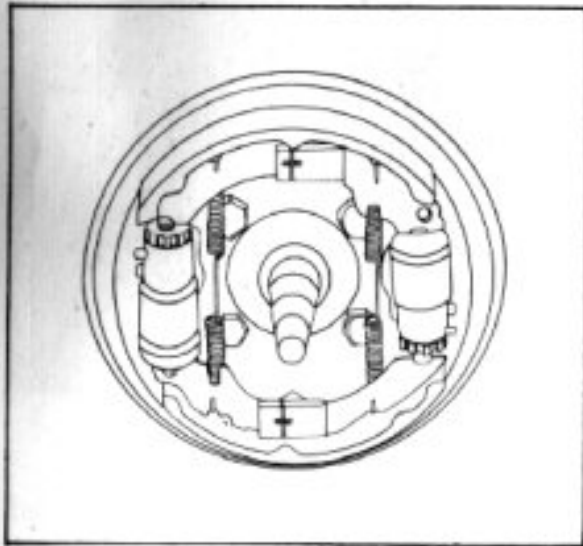

Front brake

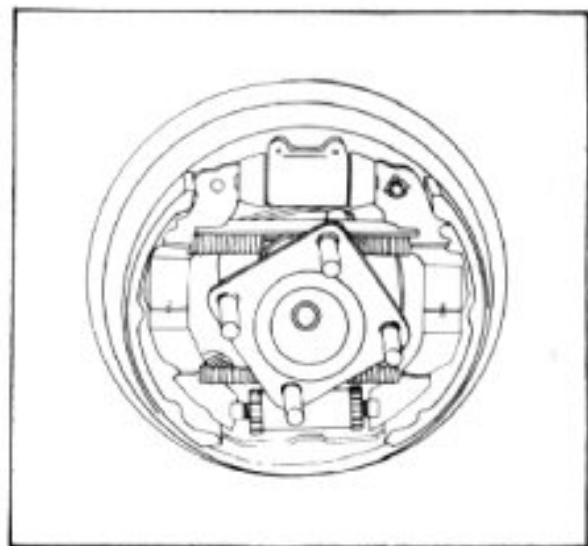

Rear brake

Caution: After adjusting the shoe clearance, when the brake pedal feeling has become soft or spongy yet, have the brake system inspected at an authorized Suzuki dealer.

Parking brake: When the parking brake lever travel becomes excessive, adjust it by following procedure.

Remove a rubber cap on the parking brake drum and rotate the propeller shaft until one of the notched sleeves is visible through a hole in the brake drum.

Insert a plane head screw driver and pry the notched sleeve one or two clicks outward.

Turn the propeller shaft until the other notched sleeve is visible and carry out the same procedure.



Changing wheel: To do this job properly, proceed as follows. Place the vehicle possibly on level ground. Move the transfer control lever to the "H" or "L" position and lock wheels by the parking brake.

Using offset box wrench in the tool kit slacken about one turn the five wheel fixing nuts.

Place jack head under the leaf spring seat, then jack up until the wheel to be removed clears the ground.

Undo and remove the five fixing nuts. Pull off the wheel.

Fit spare wheel so that the hole on the wheel disc may align with the rubber cap on the brake drum.

Screw in the five wheel fixing nuts and tighten uniformly. Lower the vehicle and disinsert jack. Retighten the five nuts firmly.

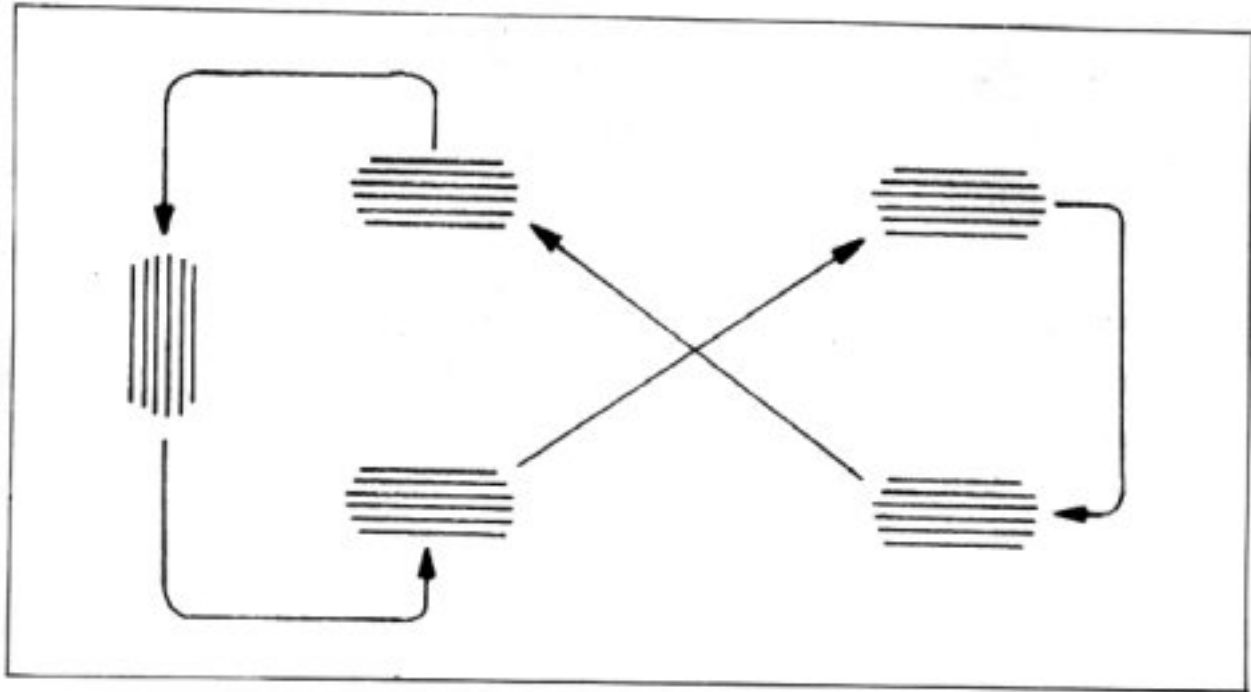

Tire rotation: To minimize the possibility of tire noise and to equalize tire wear, it is recommended that tires be interchanged every 6,000 km (3,600 mile) or more frequently in case of extremely heavy wear.

Interchanging tires will effectively prevent undue wear on any particular tire. If tire interchanging is followed as recommended above, all tires will have the same number of miles in each wheel position at the end of the fourth change.

When interchanging tire, inspect for signs of abnormal wear, bulging etc. Stones, glass and nails should be removed before reinstallation.

Tire rotation can be performed in accordance with the illustration above.

Tire inflation pressure: Tire must be kept at specified pressures. The driver should have tire pressures checked regularly when refuelling or should perform the check himself, using an accurate pressure gauge. (Be sure valve caps are properly tightened to avoid unpleasant surprises!). When checking tire pressure, tires must be cold.

	LJ20	LJ20V
Front	1.1 kg/cm ² (16 psi)	1.2 kg/cm ² (17 psi)
Rear	1.1 kg/cm ² (16 psi)	1.2 kg/cm ² (17 psi)

Soft top and canvas door removal (LJ20)

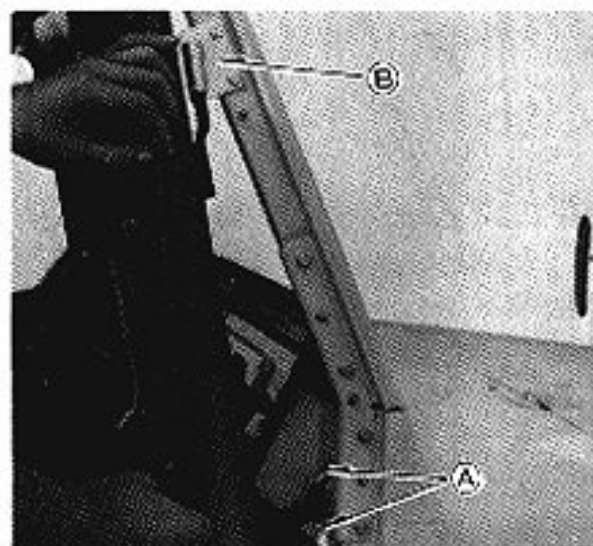

Canvas door: Loosen the stopper fixing screws A and remove a door holder B after loosening two fitting screws and take out the door lifting up slightly.

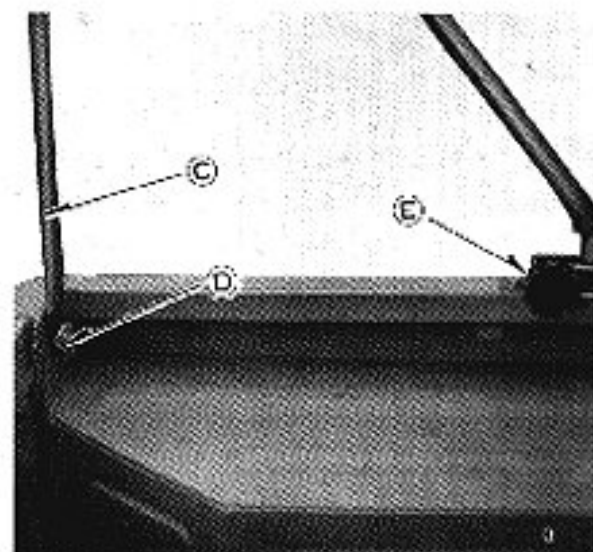

Soft top: Roll the rear curtain as described on page 16. Remove all soft top fitting clasps and hooks and unlace the soft top from the frame.

Take out the rear cross top bow C from right and left brackets after slackening the wing nuts D. Slacken right and left top bow rail knobs E.

Take out the front cross top bow A from the front roof rail B and lay down it sliding right and left tips of the front cross top bow forward.

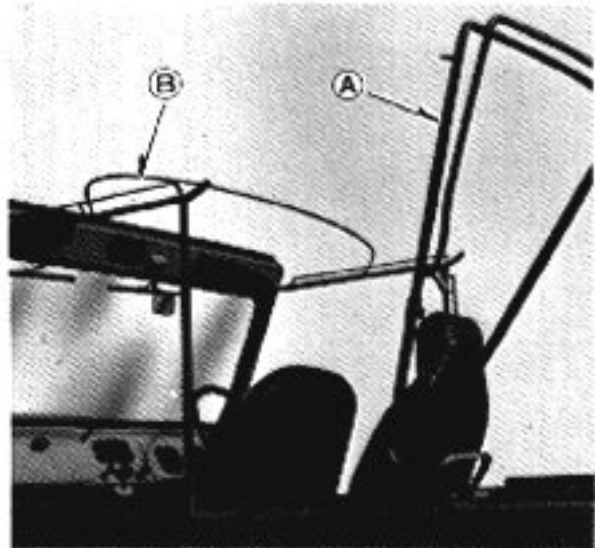

Pull out the front top bow C on the front roof side rail D and take out the front roof side rail by pressing the springs E. Then remove the center pillars F.

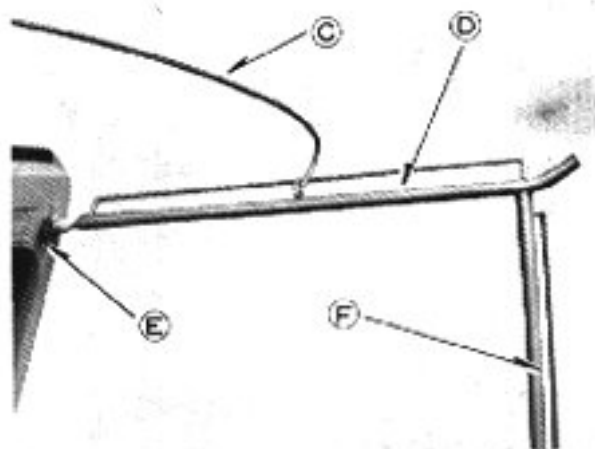

Windshield: The windshield of the LJ20 can be leaned by removing the brackets G. It will be more comfortable for you to drive a vehicle in summer.

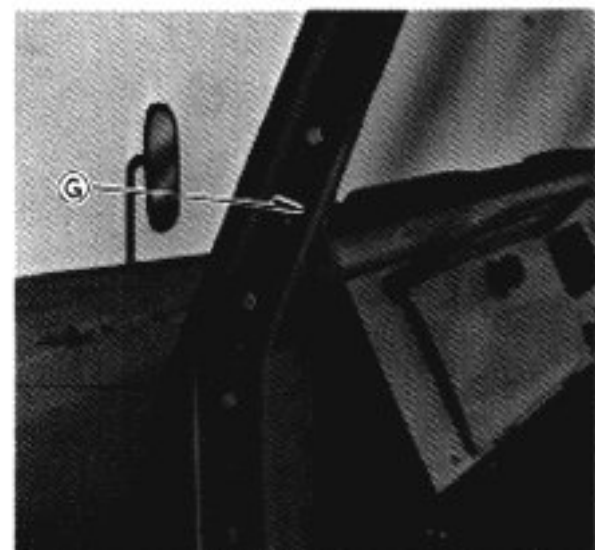

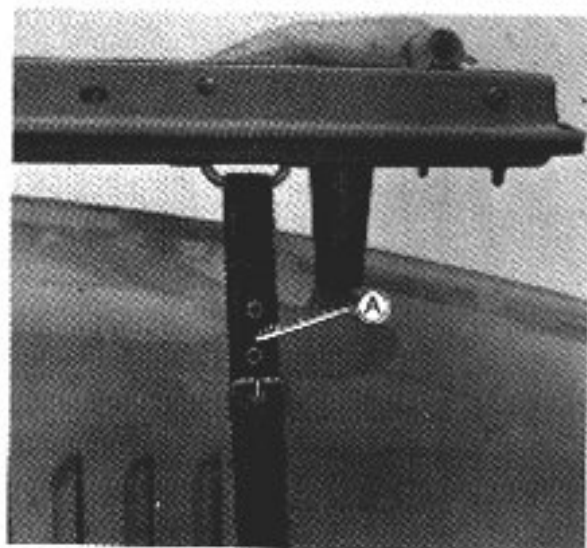

Be sure to use the windshield fixing belts A which are provided in parts case.

Electric system



Battery: Check the electrolyte level every two weeks, if necessary, add distilled water up to the upper level line. Wipe away all dirt and moisture from the top of the battery.

Head lamp: Remove the front grill after loosening two bolts and three screws.

To remove the head lamp unit A, slightly press the lens then twist the lamp unit counter-clockwise.

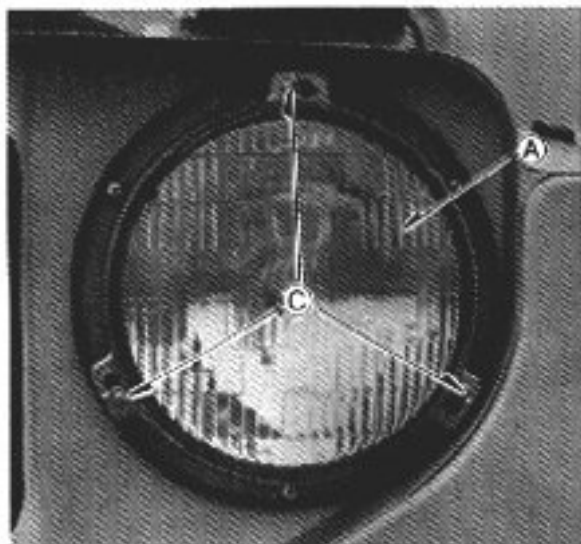

Disconnect the three-pin socket B from it.

Reinstall new head lamp unit in reverse sequence.

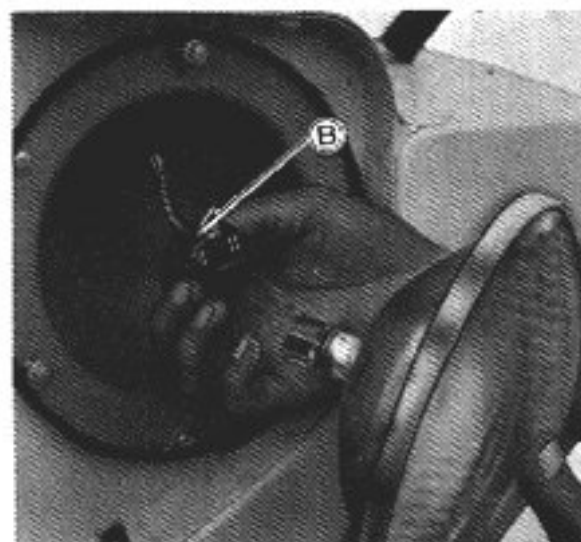

Warning: Never slacken the three head lamp beam adjustment screws C to take off the head lamp unit.

Front turn signal/Parking lamp: Remove the lens D after loosening the fitting screws E.

For bulb replacement slightly press it and turn counter clockwise.

Insert new bulb in reverse sequence.

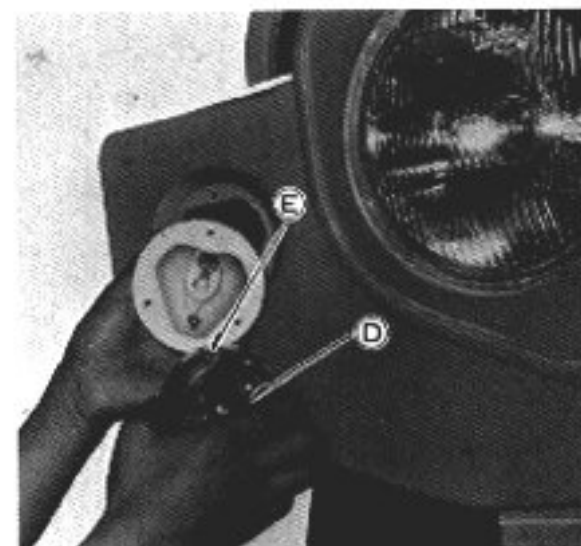

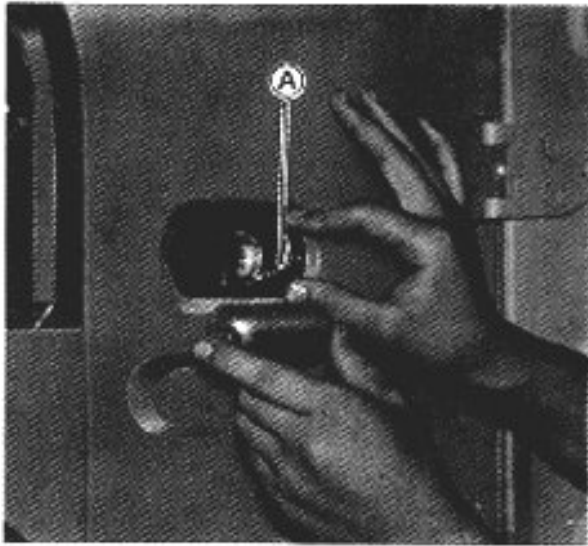

Side turn signal lamp: Bulb replacement is carried out the same procedure as "Front turn signal/Parking lamp".

Caution: When fitting the lens screw, be sure to set the earth plate A together with the lens to ground the bulb.

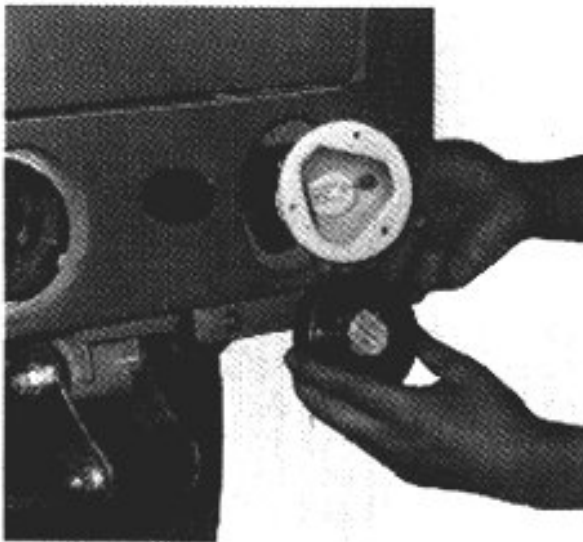

Rear turn signal/Tail/Parking lamp: Bulb replacement is carried out the same procedure as "Front turn signal/Parking lamp".

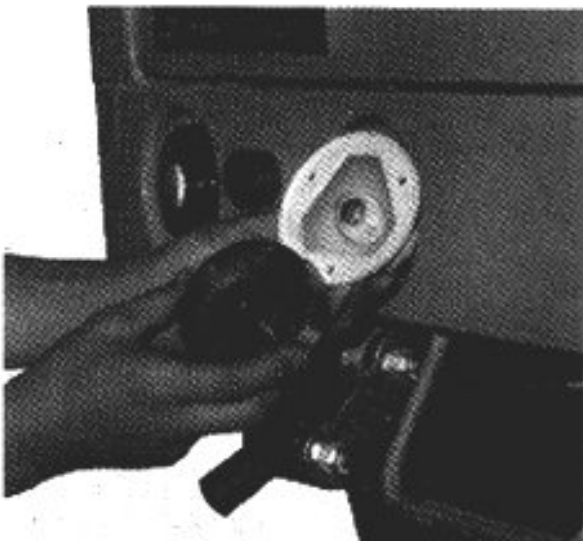

Brake lamp: Bulb replacement is carried out the same procedure as "Front turn signal/Parking lamp".

Licence lamp: Bulb replacement is carried out the same procedure as "Front turn signal/Parking lamp".

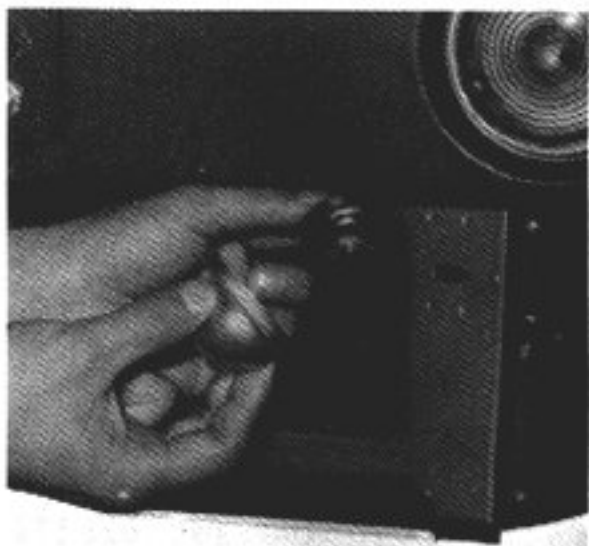

Back up lamp: Bulb replacement is carried out the same procedure as "Front turn signal/Parking lamp".



Interior lamp: Push lens by fingers from right and left and pull it toward you.

Push the tubular bulb B towards spring terminal C and take out bulb.

Insert new bulb in reverse sequence.

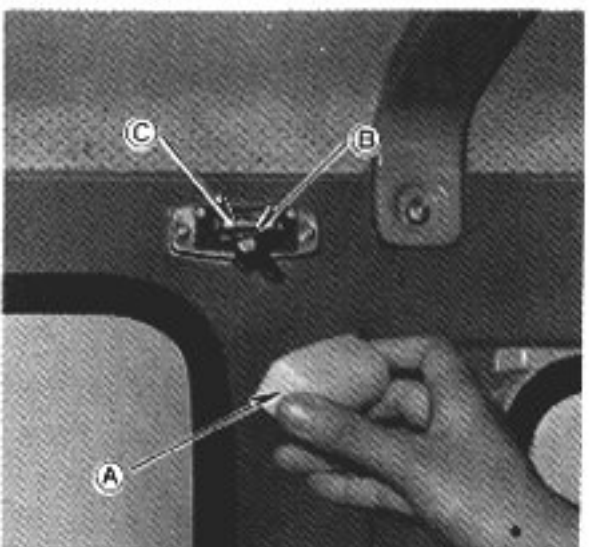

Instrument and indicator lamp: For bulb replacement pinch a holder fixed on the reverse surface of the combination meter and turn it counter-clockwise.

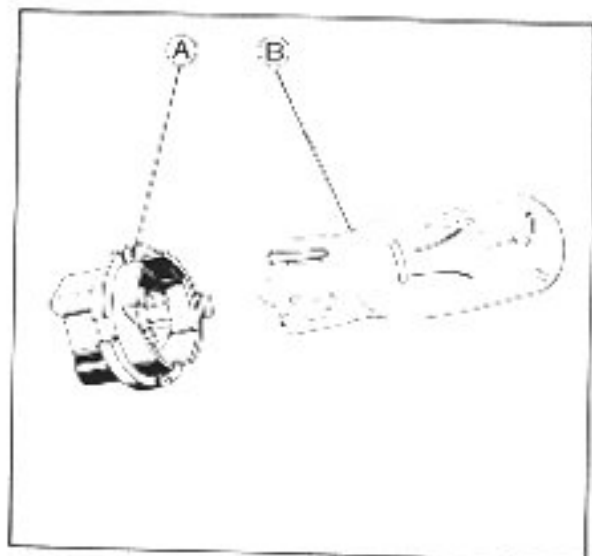
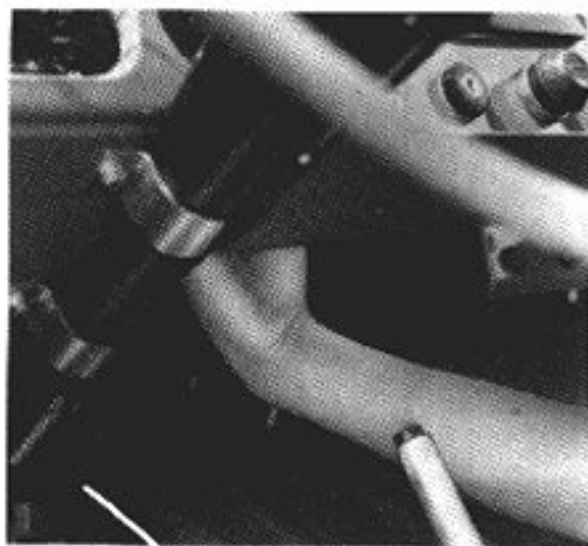

Take out the holder **A** and pull out the bulb **B** from the holder. Insert new bulb in reverse sequence.

Main fuse: Main fuse box is located on the left side behind the instrument panel. If all electrical equipments do not work, check for blown main fuse and replace. Two spare fuses are provided near the fuse box.

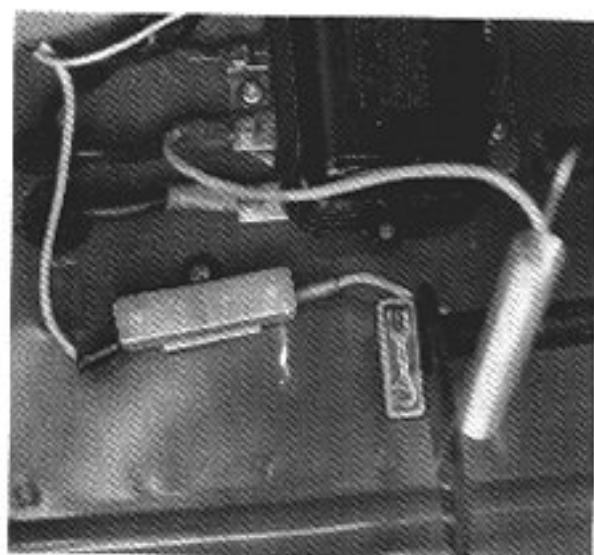
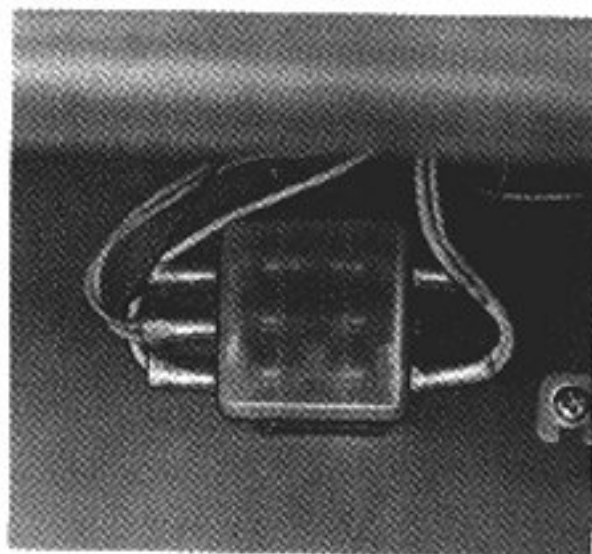

Auxiliary fuse: Fuse box is located on the right side behind the instrument panel. If electrical failures occur, check for blown fuses and replace.

Caution: If the renewed fuse blows out again, have your vehicle inspected at an authorized Suzuki dealer who is equipped and trained to locate and eliminate the cause of such problems.

Tool kit

Tool kit is provided in the glove compartment.

- | | | | |
|---|------------------------------|----|--------------------------|
| 1 | 22 x 19 mm offset box wrench | 6 | Pliers |
| 2 | Box wrench handle | 7 | Combination screw driver |
| 3 | 21 mm box wrench | 8 | Jack handle |
| 4 | 17 x 14 mm open end wrench | 9 | Jack |
| 5 | 12 x 10 mm open end wrench | 10 | Tool bag |

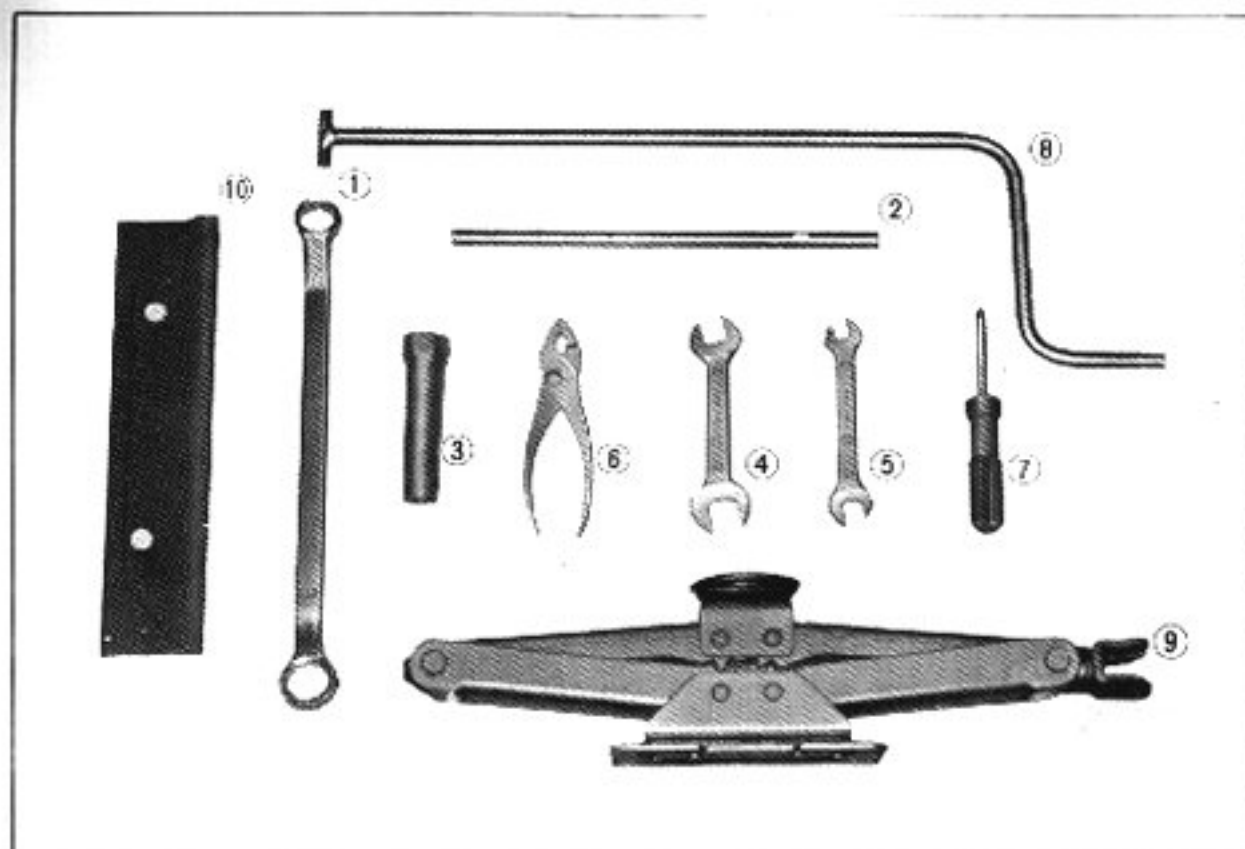

Note: Jack and jack handle are provided under the driver's seat. To remove them, pull up the jack handle and take off the rubber band which fixes the jack.

TROUBLE SHOOTING

When a trouble occurs with a vehicle, it is important to find the source of the trouble as rapidly as possible tracing it systematic procedure without bothering with parts which are functioning properly.

Starter motor will not spin

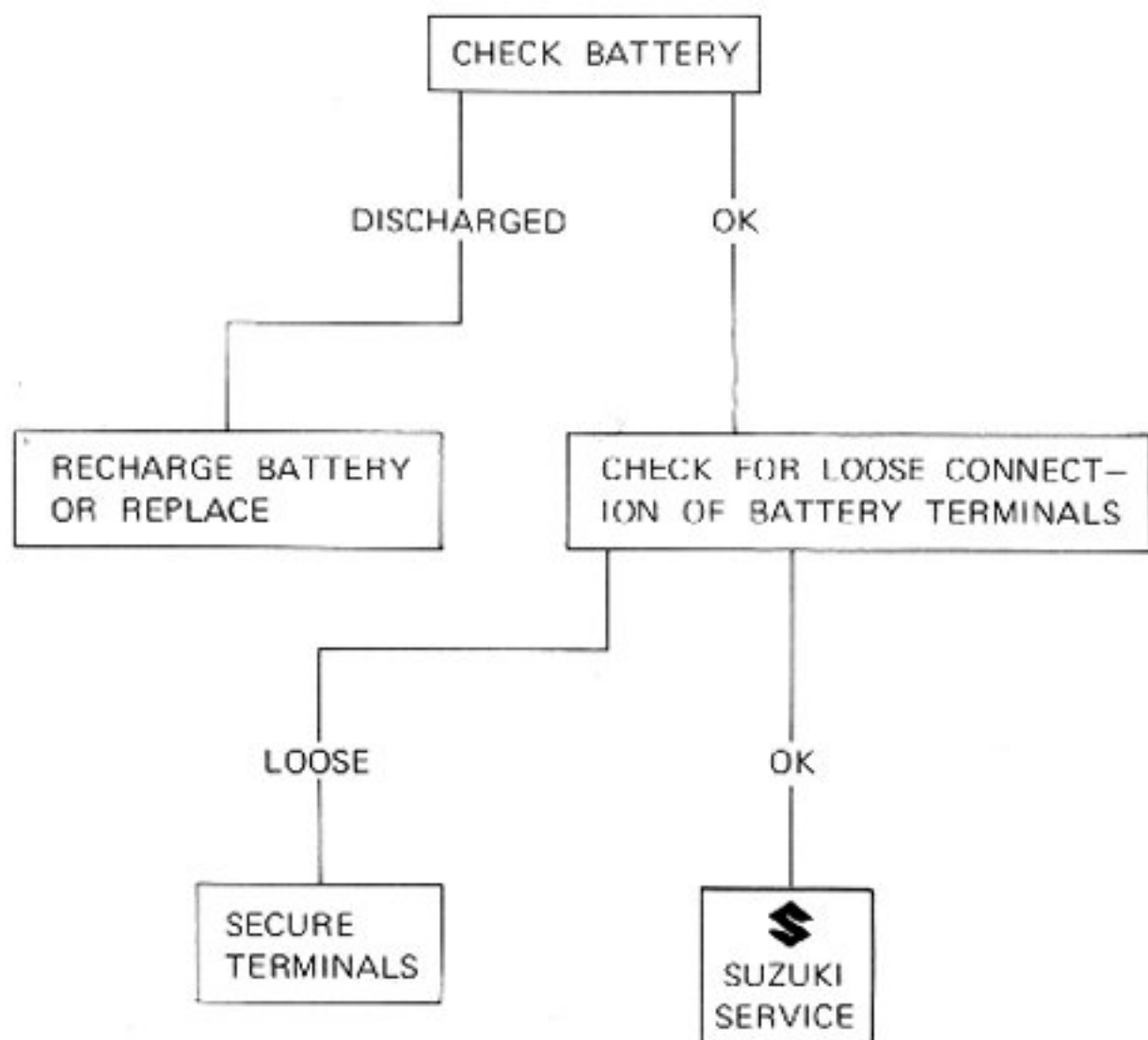

Engine does not start or does not run smoothly

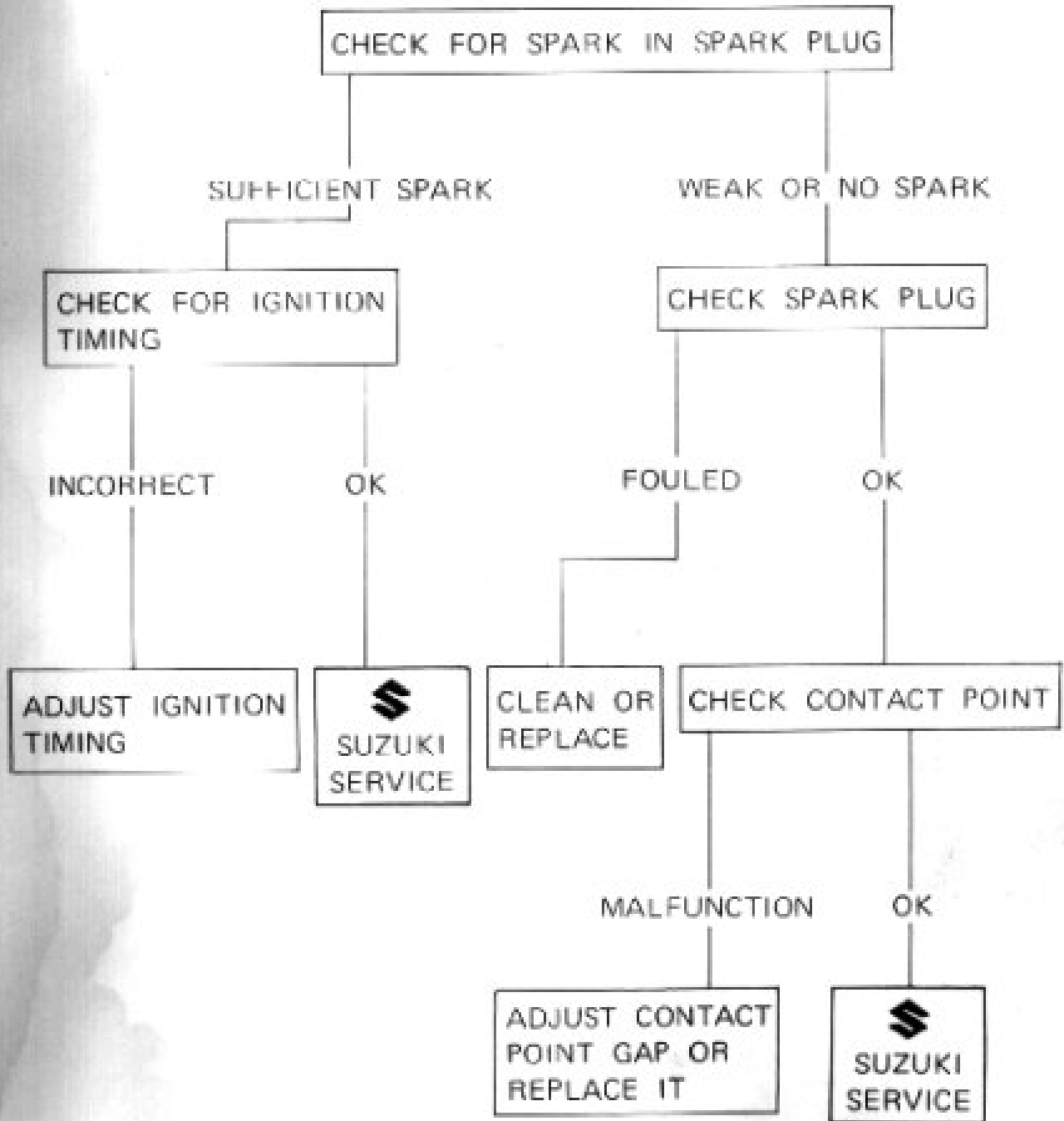

MAIN DIMENSIONS

(LJ20)

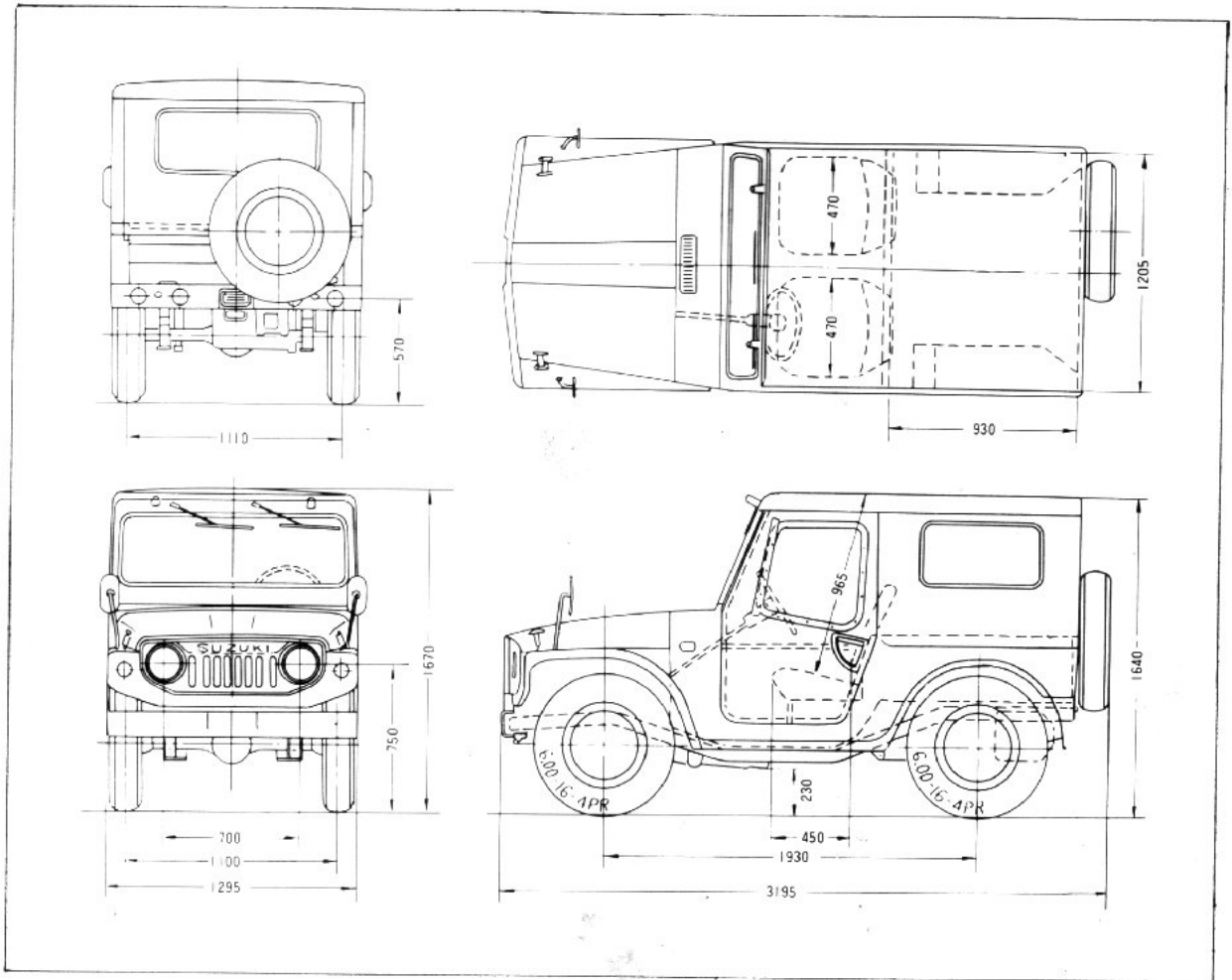

(LJ20V)

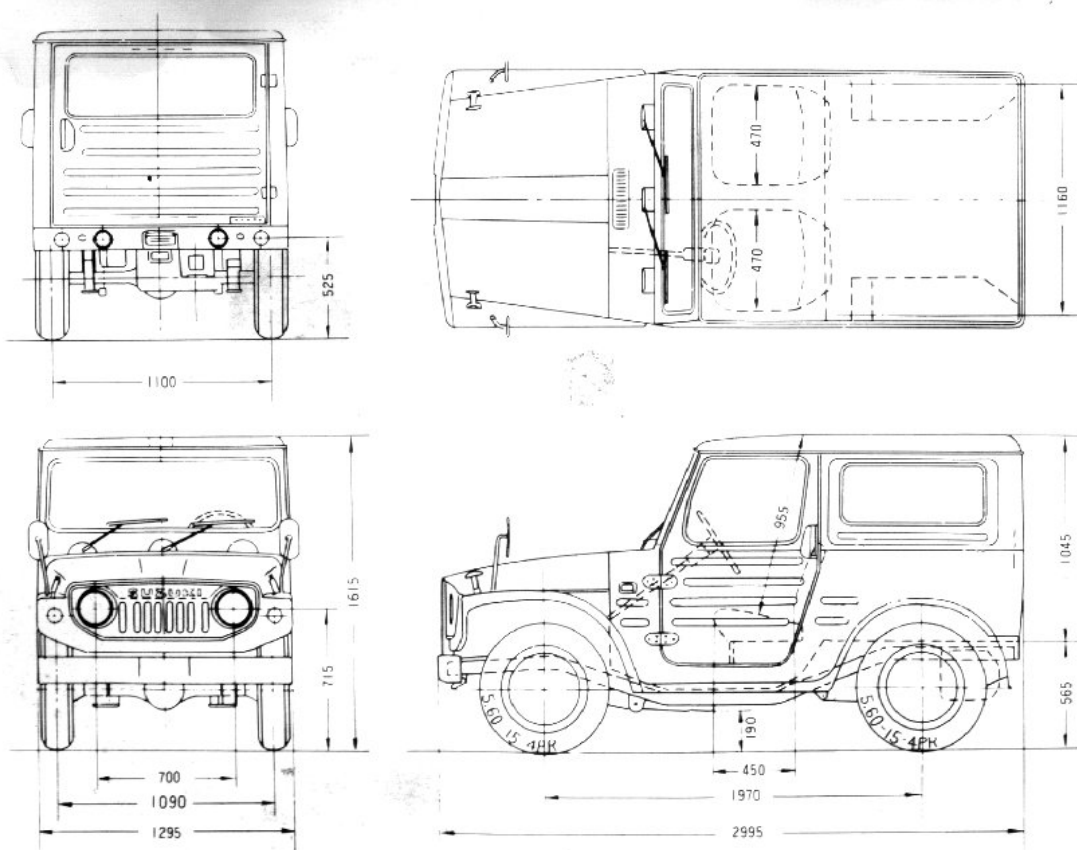

SPECIFICATIONS

	LJ20	LJ20V
Dimensions		
Overall length	3,195 mm (125.8 in)	3,025 mm (119.1 in)
Overall width	1,295 mm (51.0 in)	
Overall height	1,670 mm (65.7 in)	1,615 mm (63.6 in)
Wheelbase	1,930 mm (76.0 in)	
Road clearance	230 mm (9.1 in)	190 mm (7.5 in)
Tires	6.00-16, 4PR	5.60-15, 4PR
Tread, front	1,090 mm (76.0 in)	
rear	1,100 mm (43.3 in)	
Weight	625 kg (1,378 lb)	666 kg (1,455 lb)
Performance		
Maximum speed	80 kph (50 mph)	
Maximum torque	3.8 kg-m (27.5 lt-lb) at 5,000 rpm	
Maximum horsepower	28 hp at 5,500 rpm	
Climbing ability	$\tan \theta = 0.70, \theta = 35^\circ$ $\tan \theta = 0.64, \theta = 32.5^\circ$	
Braking distance	14.0 m at 50 kph (45.9 ft at 31 mph)	
Engine		
Type	2-cycle, water cooled gasoline engine	
Number of cylinders	Two, in line	
Bore x stroke	61.0 x 61.5 mm (2.40 x 2.42 in)	
Piston displacement	359 cc (21.9 cu in)	
Correct compression ratio	7.0 : 1	
Fuel system		
Carburetor	Single, HITACHI VCI 30	
Air cleaner	Resin processed fibrous tissue	
Fuel tank capacity	26 ltr (6.9/5.7 US/Imp gal)	

Lubrication system

Engine	Suzuki CCI system
Oil tank capacity	2.8 ltr (5.9/4.9 US/Imp pt)
Transmission case	800 cc (1.6/1.4 US/Imp pt)
Transfer case	700 cc (1.5/1.3 US/Imp pt)
Axle shaft	800 cc (1.6/1.4 US/Imp pt)
Steering gear	190 cc (6.4/6.7 US/Imp pt)

Cooling system

Type	Water cooled, pressure forced circulation
Radiator	Corrugated fin and tube pressure type
Water pump	Centrifugal type, V-belt drive
Thermostat	Wax pellet element type
Coolant amount	3.0 ltr (6.3/5.3 US/Imp pt)

Ignition system

Ignition	Battery
Ignition timing	8° at 1,400 rpm and below
Spark plug	NGK BP6HS and Nippon Denso W20FP

Transmission

Clutch	Dry, single disc
Transmission gears	4 speed forward, all synchromesh, 1 reverse
Gear ratio, low	3.967
2nd	2.388
3rd	1.527
top	1.000
reverse	3.967
Final reduction ratio	5.667

Transfer gears	2 speed	
Gear ratio, "H"	1.714	
"L"	3.013	
Overall reduction ratio	"H" position	"L" position
low	38.53	67.73
2nd	23.20	40.78
3rd	14.84	26.08
top	9.71	17.07
reverse	38.53	67.73
Suspension		
Suspension, front	Semi-elliptic, leaf spring	
rear	Semi-elliptic, leaf spring	
Shock absorber, front	Telescopic, double action	
rear	Telescopic, double action	
Steering		
Type	Ball screw nut type	
Steering angle, inner	33°	
outer	28°	
Toe-in	5 mm (0.20 in)	4 mm (0.16 in)
Camber	1°	
Caster	0.5°	
King pin angle	9°	
Turning radius	4.4 m (14.4 ft)	
Brakes		
Foot brake	Hydraulic, four wheels	
Parking brake	Mechanical, propeller shaft	

LJ20

LJ20V

Brake shoes, front	2 leading	
rear	Leading and trailing	
Carrying capacity		
Height of load deck from ground	610 mm (24.0 in)	565 mm (22.2 in)
Size of load deck (L x W x H)	930 x 1205 x 310 mm (36.6 x 47.4 x 12.1 in)	820 x 1160 x 1045 mm (32.2 x 45.7 x 41.1 in)
Maximum load	250 kg (550 lb)	200 kg (440 lb)
Seat	2 persons	
Electrical equipment		
Generator	12V 13A	
Starter	12V 300W	
Battery	12V 24AH	

SPECIFICATION SUBJECT TO CHANGE WITHOUT NOTICE.

You may find some slight differences between your vehicle and this owner's manual. This is because of differences required by traffic regulations in different countries.

Ref. No.	Items	Q'TY	Specifications
1	Headlamp	2	12V 50/40W
2	Turn signal, tail & parking lamp	4	12V 23/8/3.4W
3	Brake lamp	2	12V 23W
4	Licence lamp	1	12V 10W
5	Back-up lamp	1	12V 10W
6	Side turn signal lamp	2	12V 6W
7	Meter lamp	1	12V 3.4W
8	Indicator lamp	5	12V 3.4W
9	Interior lamp	1	12V 5W
10	Main fuse	1	12V 30A
11	Auxiliary fuse	3	12V 5/10/15A

	Wire color
Bk	Black
Bl	Blue
G	Green
R	Red
W	White
Y	Yellow
Bk/W	Black with White tracer
Bk/Y	Black with Yellow tracer
Bl/W	Blue with White tracer
G/Bl	Green with Blue tracer
G/R	Green with Red tracer
G/W	Green with White tracer
G/Y	Green with Yellow tracer
R/Bk	Red with Black tracer
R/Bl	Red with Blue tracer
R/G	Red with Green tracer
R/W	Red with White tracer
R/Y	Red with Yellow tracer
W/R	White with Red tracer
Y/Bk	Yellow with Black tracer
Y/R	Yellow with Red tracer

TIGHTENING TORQUE OF IMPORTANT PARTS

It is necessary to retighten these items as shown below every 3,000 km (2,000 mile). Have your vehicle check to an authorized Suzuki dealer.

Item	Q'ty	Tightening Torque (Kgm)
Nut, plate spring shackle	8	250 ~ 700
Nut, spring	4	400 ~ 800
Nut, U bolt	16	300 ~ 450
Nut, wheel	20	500 ~ 800
Nut, front wheel shaft	2	1500 ~ 2700
Nut, rear hub	8	500 ~ 800
Bolt, king pin	16	200 ~ 300
Nut, steering rubber joint	4	150 ~ 250
Bolt, rubber joint flange	2	300 ~ 400
Bolt, steering gearbox	3	700 ~ 900
Bolt, gearbox stay	1	350 ~ 550
Nut, rear backing plate	8	180 ~ 280
Bolt, cross joint flange yoke	24	150 ~ 250